

6600A SERIES
PROGRAMMABLE SWEEP GENERATORS,
MULTIBAND MODELS
OPERATION AND MAINTENANCE MANUAL

MODELS COVERED

6609A	6629A-40	6647A
6617A	6637A	6648A
6621A	6637A-40	6653A
6621A-40	6638A	6659A
6629A	6642A	

WILTRON

P.O. BOX 7290 • 805 E. MIDDLEFIELD ROAD • MOUNTAIN VIEW, CA 94042-7290
TEL. (415) 969-6500 • TWX 910-379-6578

1-6600A/MB-OMM
REPRINTED: OCTOBER 1983
COPYRIGHT 1982 WILTRON CO.

WARRANTY

All products are warranted against defects in materials and workmanship for one year from the date of shipment except YIG-tuned oscillators, which have a two-year warranty period. Our obligation covers repairing or replacing products which prove to be defective during the warranty period and which shall be returned with transportation charges prepaid to WILTRON. Obligation is limited to the original purchaser. We are not liable for consequential damages.

MANUAL CHANGES

MANUAL: 6600A Series Multiband Sweep Generators

MANUAL PRINT DATE: October 1982

CHANGE DATE: May 15, 1983

INSTRUCTIONS:

1. Make all errata changes. Errata changes are listed in numerical order by page and paragraph number. Errata that has surfaced since January 15, 1982, the date of the last change notice, are indicated with the ► symbol.
2. Make the "Change #" changes if they have an applicable serial number. Each 6600A series instrument has two serial numbers: one for the RF deck and another for the basic frame. If all models are affected, the change is usually to the basic frame itself or one of its PCBs (A1 thru A5 or A10 thru A14). If the change is to one or more model numbers (e.g., 6609A, 6647A, 6647A-50), however, the change is to the RF deck or one of its PCBs (A6 thru A9). The serial numbers are imprinted on labels. For the basic frame, the label is affixed to the inside surface of the rear panel; for the RF deck, the label is affixed to the outside surface of the rear panel.

ERRATA

1. Page 1-2, Paragraph 1-5, Option 13

- a. Change the first two lines to read, "Option 13, Hardware Interface to HP 5343 Microwave Counter."
- b. Add:

"NOTE

Option 13 does not provide an interface with the HP 5342A Microwave Counter."

► 2. Page 2-3, paragraph 2-4.3

Change the 3rd sentence to read: "This cable — WILTRON Part No. 2100-1, -2, or -4..."

3. Page 5-11, Paragraph 5-6d, step 2(a)(3)

Change the frequency to read, "400 MHz."

4. Page 5-17, Paragraph 5-8

- a. Change the 6th and 7th lines to read: "There are two field-level adjustments on each YIG Driver PCB (see note):"

MANUAL CHANGES (Continued)

b. Add below the paragraph:

NOTE

The 660-D-12868-3 YIG Driver PCB used in the Models 6609A-50, 6617A-40, 6637A-40, and 6647A-40, and the 660-D-12868-99-91 YIG Driver PCB used in the Model 6621A-40, contain three field-level adjustments: the two mentioned above, plus a +15V bias adjustment for the RF amplifier that follows the YIG 1 oscillator (RF deck). This adjustment is described in paragraph 5-8.3.

5. Page 5-23

a. Add the following paragraph between step(g)(2) and paragraph 5-9:

"5-8.3 RF Amplifier Bias Adjustment

This paragraph provides instructions for adjusting the bias to the RF amplifier that follows the YIG 1 oscillator (RF deck) on Models 6609A-50, 6617A-40, 6621A-40, 6647A-40, and 6659A-40.

- a. Set up the equipment as shown in Figure 5-22, and turn the equipment on.
- b. Remove the top cover from the sweep generator, refer to paragraph 7-3.1, if necessary.
- c. Connect the multimeter leads between TP1 (-) and TP3 (+) (Figure 5-20A).
- d. Adjust A6R94 for 15 ± 0.5 volts."

b. Add Figure 5-20A, below.

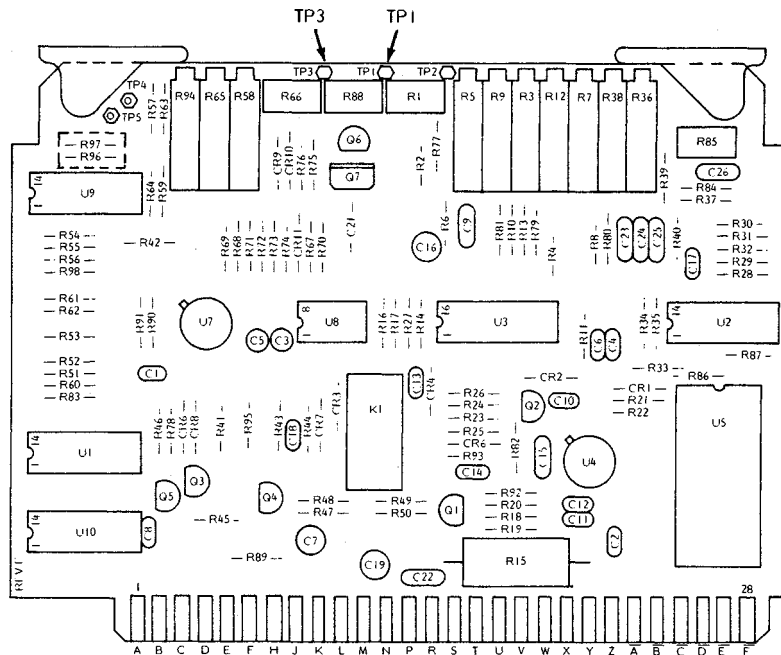

Figure 5-20A. A6 PCB RF Amplifier Bias Adjustment, Models 6609A-50, 6617A-40, 6621A-40, 6637A-40, and 6647A-40

MANUAL CHANGES (Continued)

6. Page 5-23, Paragraph 5-9

Add the following note between paragraph 5-9 and Table 5-6:

"NOTE

Recheck the frequency-band overlap adjustments (paragraph 5-6d) following frequency calibration."

▶ 7. Page 6-5, Figure 6-2, "Coupler Assembly (No RF OUTPUT Options)"

Add item b.1 as follows, between items b. and c.

<u>INDEX NO.</u>	<u>NAME</u>	<u>PART NO.</u>
b.1	6653A/6650A	660-B-8125-6

8. Pages 6-50 thru 6-52, Table 6-24

a. Add:

<u>REF. DES.</u>	<u>DESCRIPTION</u>	<u>WILTRON PART NO.</u>
<u>CAPACITORS</u>		
C37	Disc, Ceramic, 1 kV, 0.001 μ F	230-3
C38	Disc, Ceramic, 1 kV, 0.01 μ F	230-40
C39	Tantalum, 35V, 1 μ F	250-19
C40	Monolithic, 100V, 0.1 μ F	230-37
C41	Monolithic, 100V, 0.1 μ F	230-37
<u>CONNECTORS</u>		
P40	3-Pin, Right Angle	551-238
P41	3-Pin, Right Angle	551-238
P42	3-Pin, Right Angle	551-238
P43	3-Pin, Right Angle	551-238
P44	3-Pin, Right Angle	551-238
<u>RESISTORS</u>		
R109	MF, 1/4W, 0.1%, 10 k Ω	113-10k-.1
R110	MF, 1/4W, 0.1%, 10 k Ω	113-10k-.1
R111	MF, 1/4W, 0.1%, 10 k Ω	113-10k-.1
R112	MF, 1/4W, 0.1%, 10 k Ω	113-10k-.1
R113	MF, 1/4W, 0.1%, 10 k Ω	113-10k-.1
R114	MF, 1/4W, 0.1%, 10 k Ω	113-10k-.1
R115	MF, 1/4W, 0.1%, 10 k Ω	113-10k-.1
R116	MF, 1/4W, 0.1%, 10 k Ω	113-10k-.1

MANUAL CHANGES (Continued)

INTEGRATED CIRCUITS

U11	Op Amp, LF356N	50-9
U12	Op Amp, LF356N	50-9

MISCELLANEOUS

T1	Transformer Assembly	SPEC-A-11773
T2	Transformer Assembly	SPEC-A-11773

b. Delete:

- (1) From the "DIODES AND BRIDGE RECTIFIER" grouping: CR10.
- (2) From the "CONNECTORS" grouping: P8, P33, and P38.
- (3) From the "MISCELLANEOUS" grouping: L1 and L2.

9. Page 7-27, Paragraph 7-6.2, 4th paragraph, 11th line

Starting with the sentence reading "Note that Table 7-5 signatures...," delete the remaining lines.

10. Page 7-85, Figure 7-43

Add the "LOG AMP/SHAPER" circuit as show below.

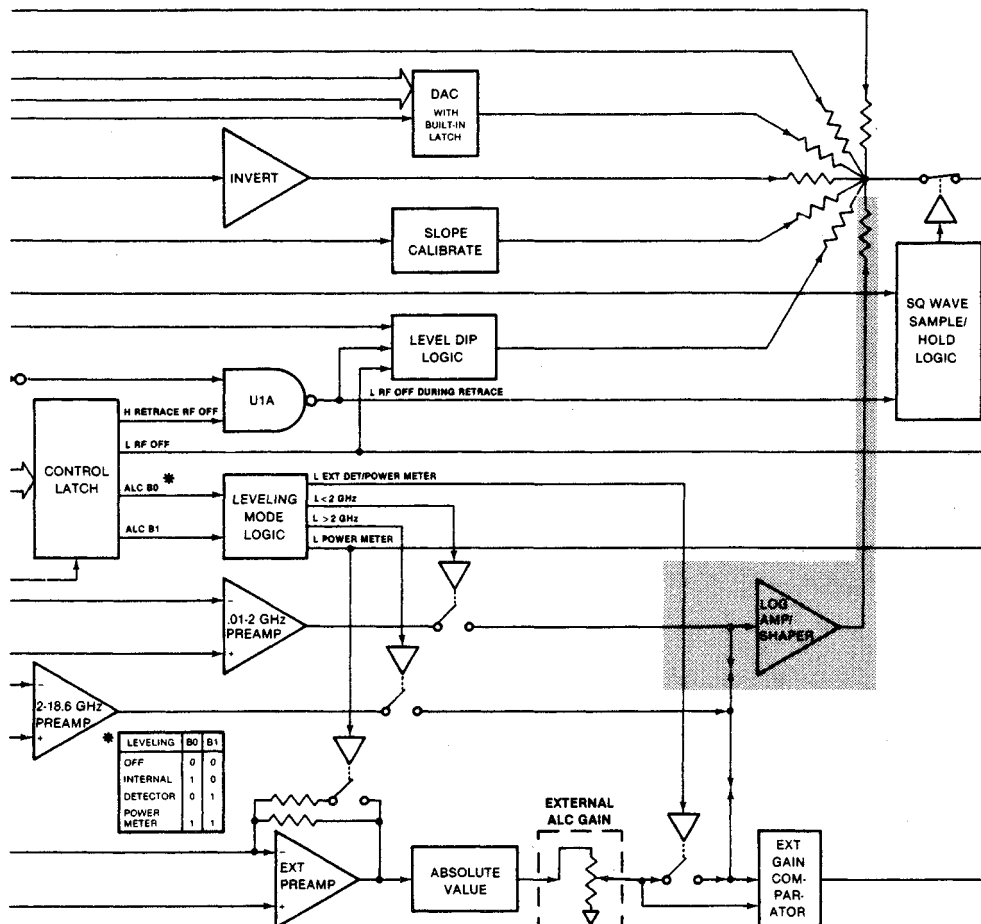

MANUAL CHANGES (Continued)

- ▶ 11. Page 7-114, Table 7-17, lines 28 and 29 (2nd and 3rd lines from the bottom)

Change the entry in the "Schematic Fig. No." column to read, "7-82A."

- 12. Page 7-123

Copy Figure 1 and affix to page 7-124, on top of the existing "A6 PCB Parts Locator Diagram."

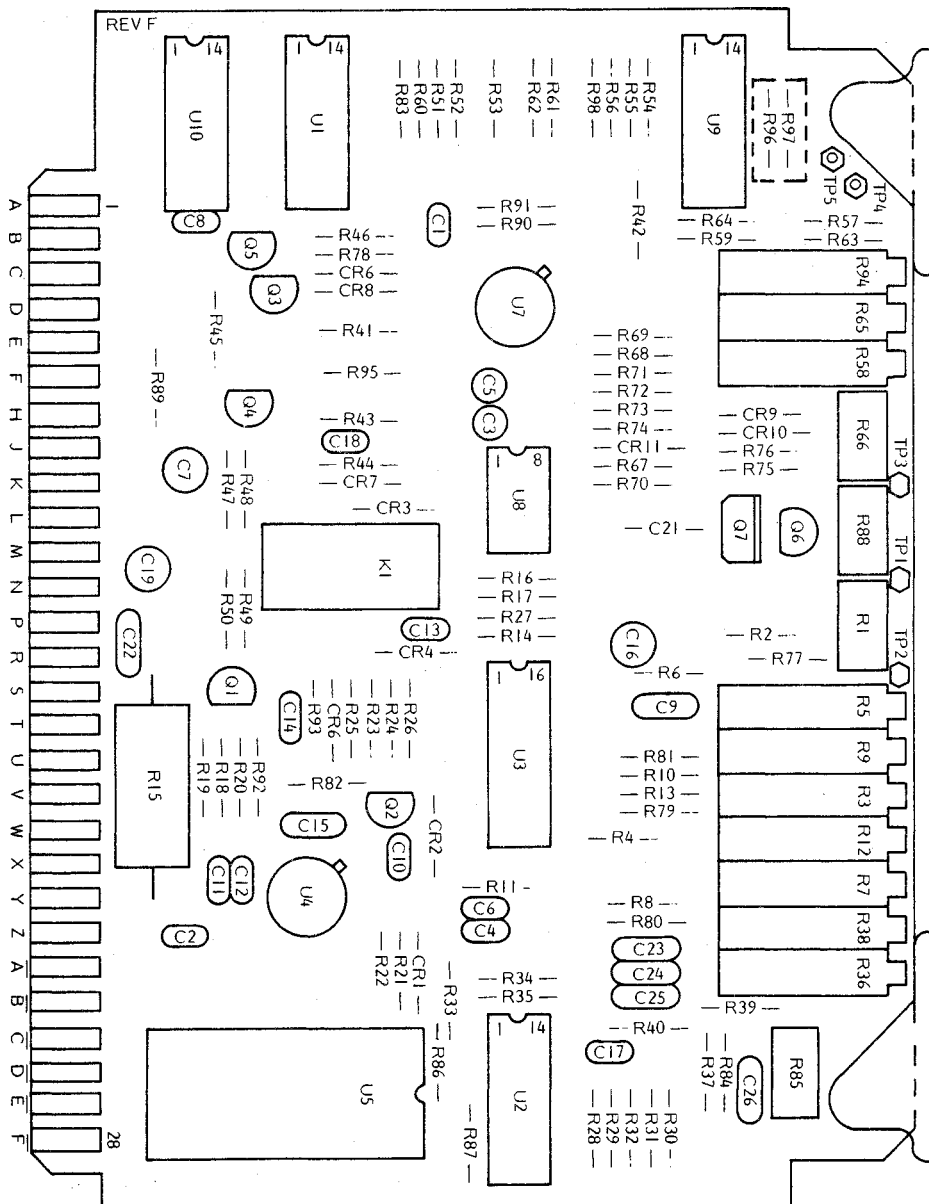

Figure 1. Corrected A6 PCB Parts Locator Diagram

MANUAL CHANGES (Continued)

►13. Page 7-155, Figure 7-77, Sheet 3

- a. In the section labeled, "A14 MOTHERBOARD":
 - (1) Change "P15-5" to read, "P15-4."
 - (2) Change "P15-9" to read, "P15-8."
- b. In the section labeled, "RF COMPONENTS DECK":
 - (1) Change "J15-5" to read, "J15-4."
 - (2) Change "J15-9" to read, "J15-8."
 - (3) Change the block labeled, "OSC 3 YIG," to read, "OSC 2 YIG"; change the frequency to read, "8-12.4 GHz."
 - (4) In the block labeled, "AMP," change the frequency to read, "8-12.4 GHz."

►14. Page 7-164, Figure 7-80, Sheet 3

- a. In the section labeled, "A14 MOTHERBOARD":
 - (1) Change "CR20" to read, "CR22."
 - (2) Change "R32" to read, "R45."
 - (3) Change "Q7" to read, "Q16."
 - (4) Change "R33" to read, "R44."
 - (5) Change "Q12" to read, "Q15."
 - (6) Change "R42" to read, "R43."
 - (7) Change "Q13" to read, "Q14."
 - (8) Change "R37" to read, "R50."
- b. In the section labeled, "RF COMPONENTS DECK":
 - (1) Change "A7L1" to read, "A8L1."
 - (2) Change "A7C1" to read, "A8C1."

►15. Page 7-167, Figure 7-81, Sheet 3

- a. In the section labeled, "A14 MOTHERBOARD":
 - (1) Change "CR20" to read, "CR34."
 - (2) change "R32" to read, "R47."
 - (3) Change "Q7" to read, "Q19."
 - (4) Change "R33" to read, "R46."
 - (5) Change "Q12" to read, "Q18."
 - (6) Change "R42" to read, "R48."
 - (7) Change "Q13" to read, "Q17."
 - (8) Change "R37" to read, "R68."
- b. In the section labeled, "RF COMPONENTS DECK":
 - (1) Change "A7L1" to read, "A9L1."
 - (2) Change "A7C1" to read, "A9C1."

►16. Page 7-170

Add pages 7-170A, 7-170B, and 7-170C/7-170D; Figure 7-82A, Sheets 1 thru 3; following.

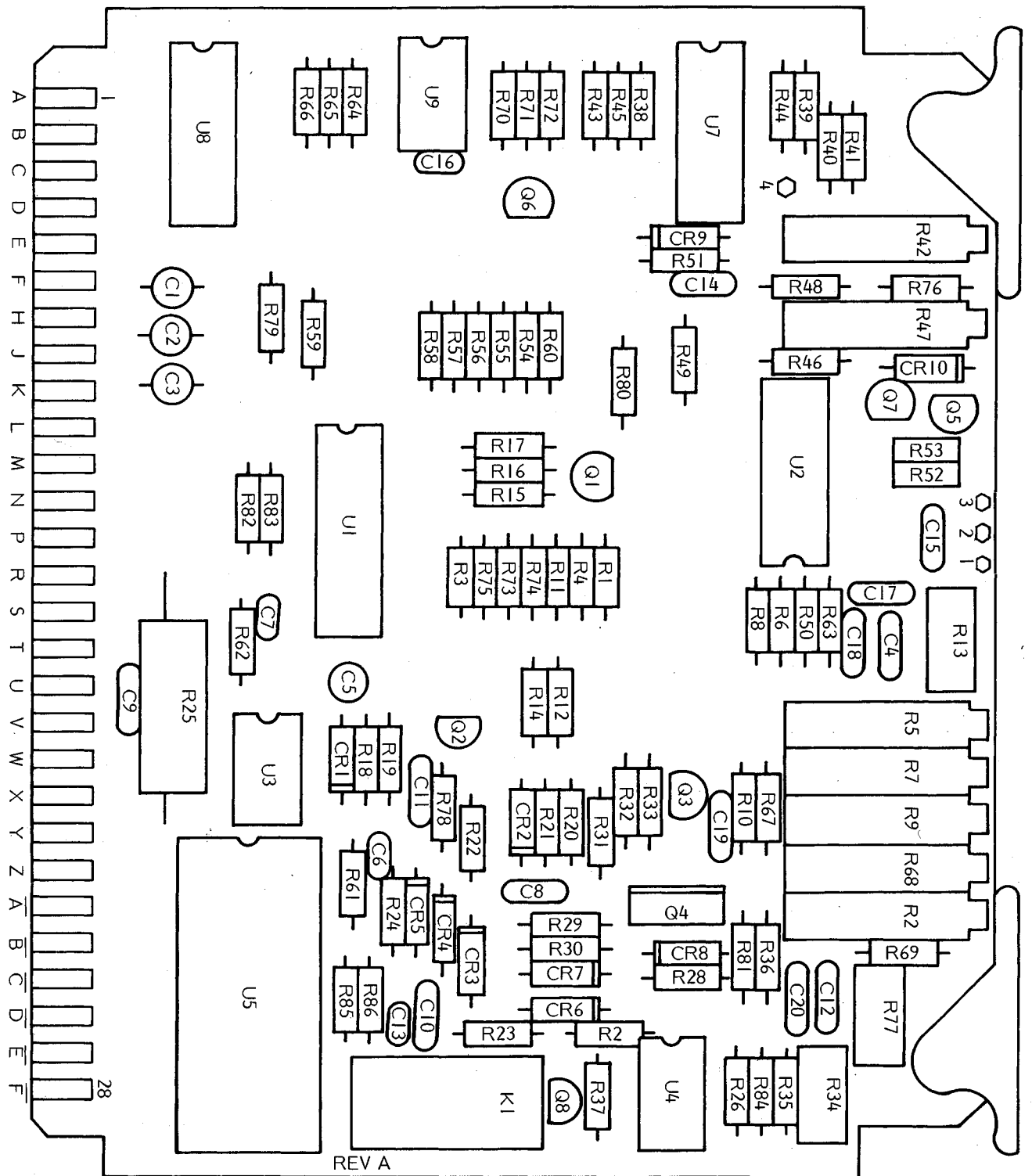

A7/A8 PCB Parts Locator Diagram

1-6600A/MB-OMM
 Changed: 15 May 83

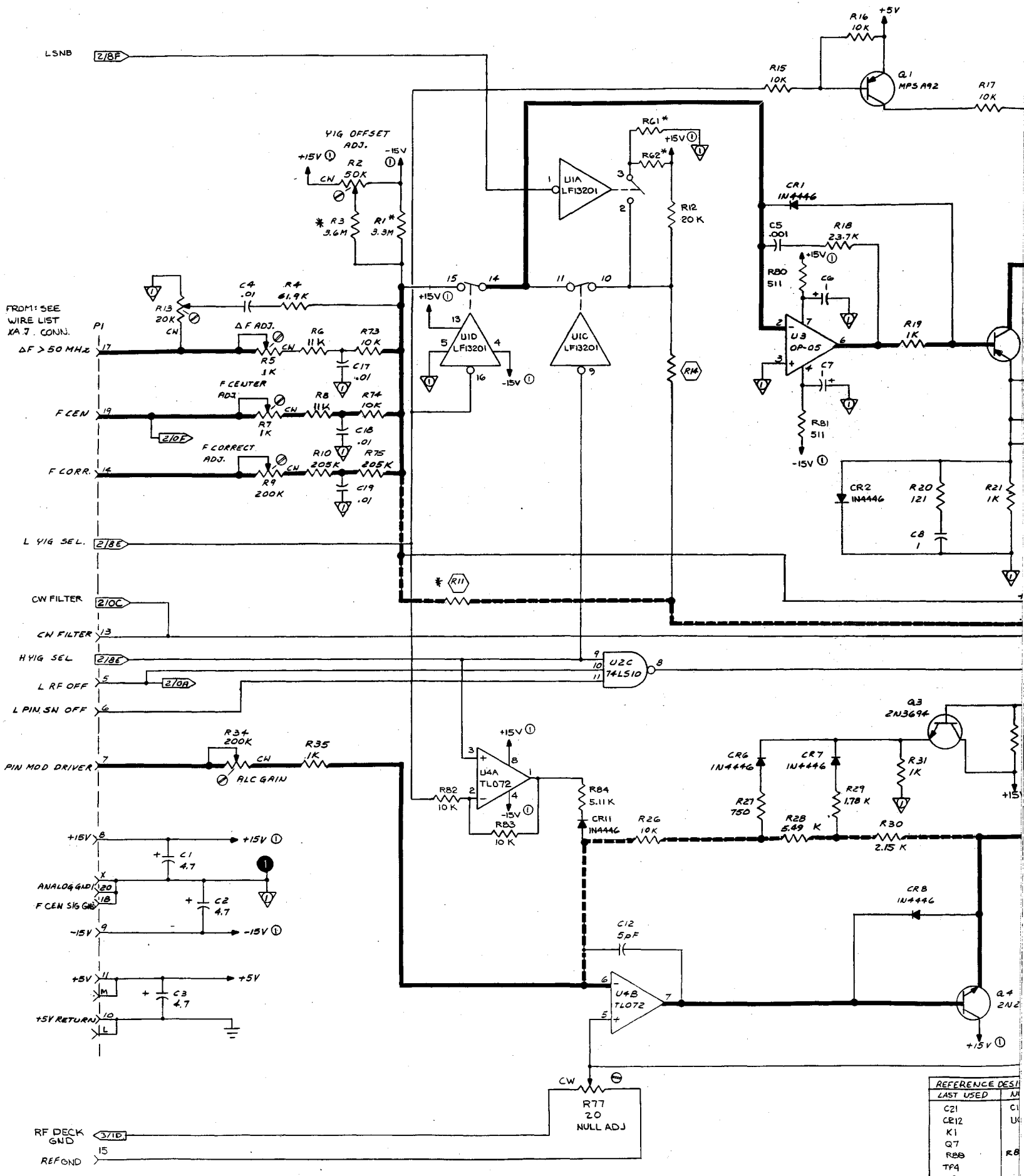

REFERENCE DESI	
LAST USED	NA
C21	C1
CR12	U4
K1	
Q7	R8
R28	
TP4	
U9	

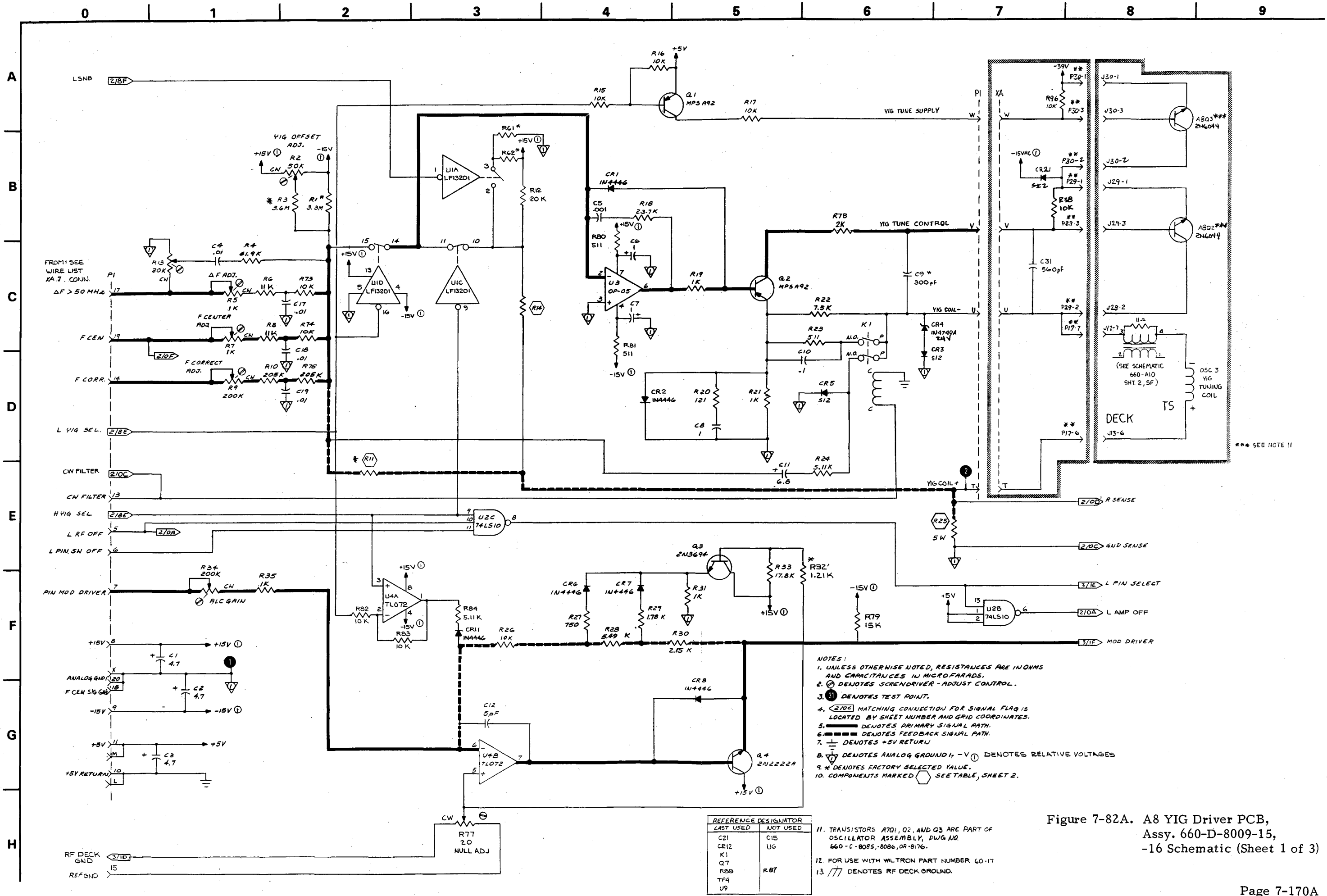
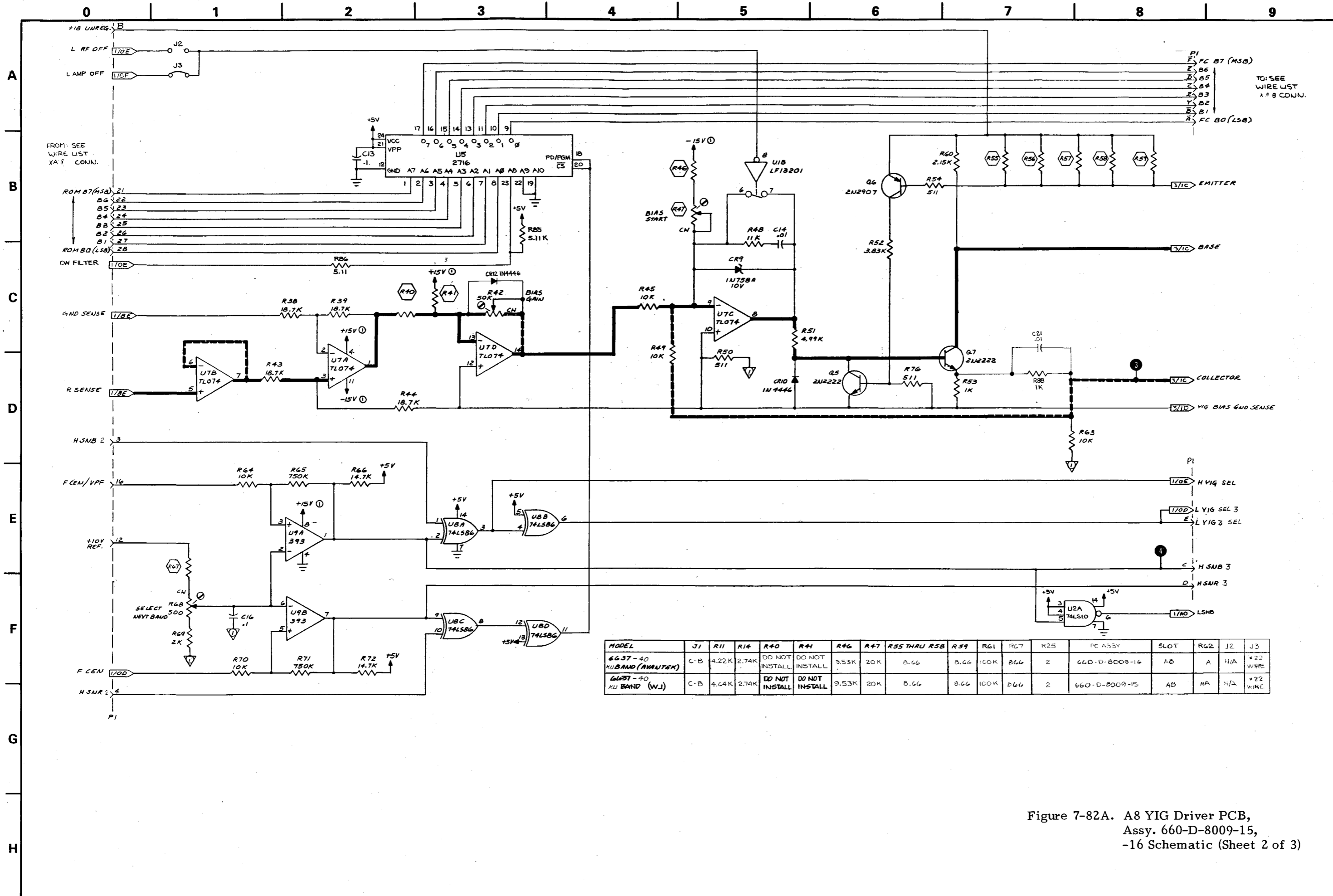
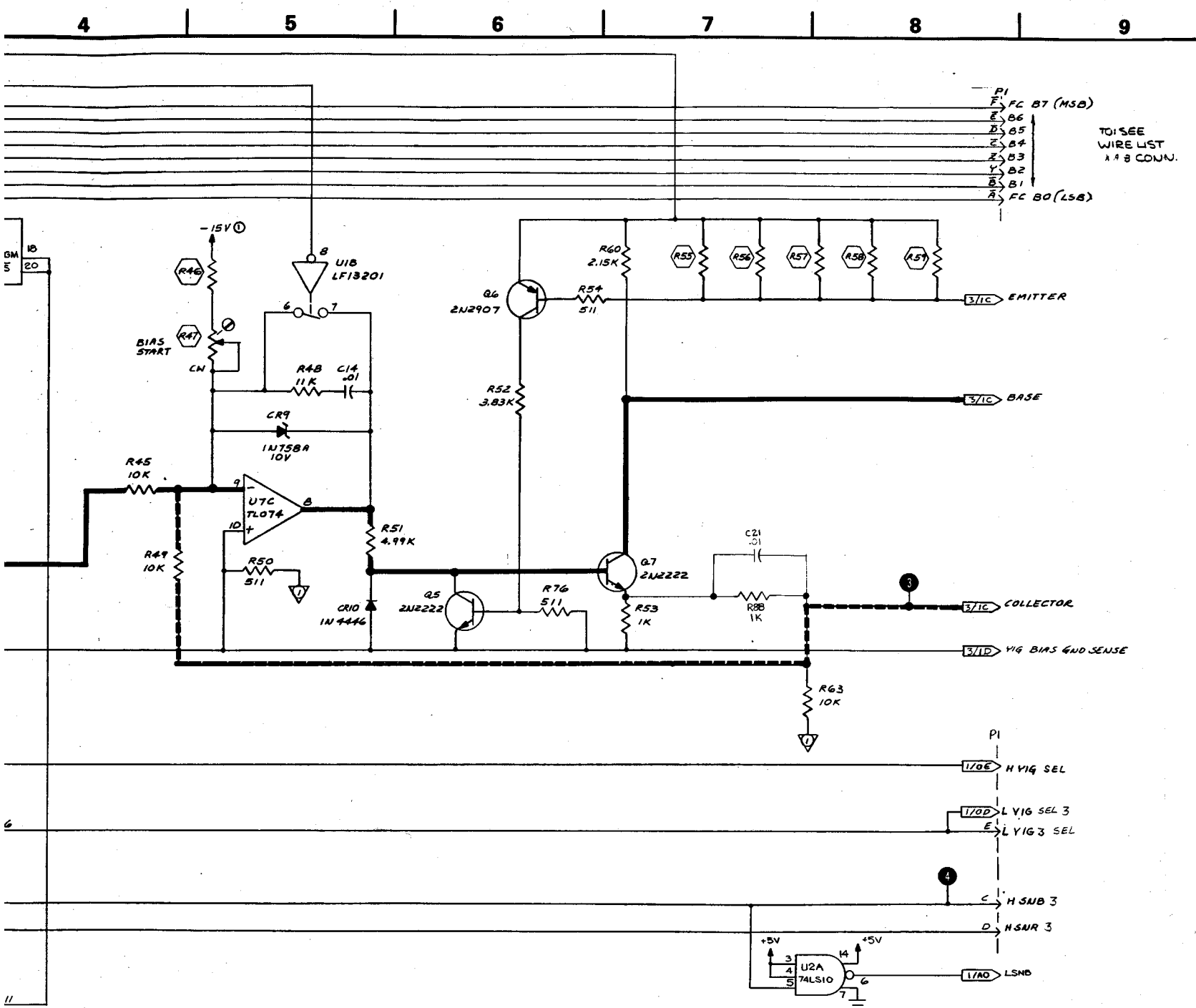

Figure 7-82A. A8 YIG Driver PCB, Assy. 660-D-8009-15, -16 Schematic (Sheet 1 of 3)



MODEL	J1	R11	R14	R40	R44	R46	R47	R55 THRU R58	R59	R61	R67	R25	PC ASSY	SLOT	RG2	J2	J3
6637-40 KU BAND (ANALTEK)	C-B	4.22K	2.74K	DO NOT INSTALL	DO NOT INSTALL	9.53K	20K	8.66	8.66	100K	866	2	660-D-8009-14	AB	A	N/A	#22 WIRE
6637-40 KU BAND (WJ)	C-B	4.64K	2.74K	DO NOT INSTALL	DO NOT INSTALL	9.53K	20K	8.66	8.66	100K	866	2	660-D-8009-15	AB	NA	N/A	#22 WIRE

Figure 7-82A. A8 YIG Driver PCB,
Assy. 660-D-8009-15,
-16 Schematic (Sheet 2 of 3)



MODEL	J1	R11	R14	R40	R41	R46	R47	R55 THRU R58	R59	R61	R67	R25	PC ASSY	SLOT	R62	J2	J3
6637-40 KU BAND (AMNTEK)	C-B	4.22K	2.74K	DO NOT INSTALL	DO NOT INSTALL	9.53K	20K	8.66	8.66	100K	866	2	660-D-8009-16	A8	A	N/A	#22 WIRE
6637-40 KU BAND (WJ)	C-B	4.64K	2.74K	DO NOT INSTALL	DO NOT INSTALL	9.53K	20K	8.66	8.66	100K	866	2	660-D-8009-15	A8	NA	N/A	#22 WIRE

Figure 7-82A. A8 YIG Driver PCB,
Assy. 660-D-8009-15,
-16 Schematic (Sheet 2 of 3)

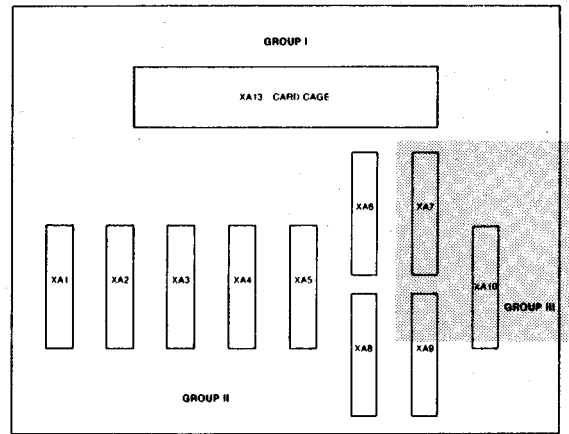
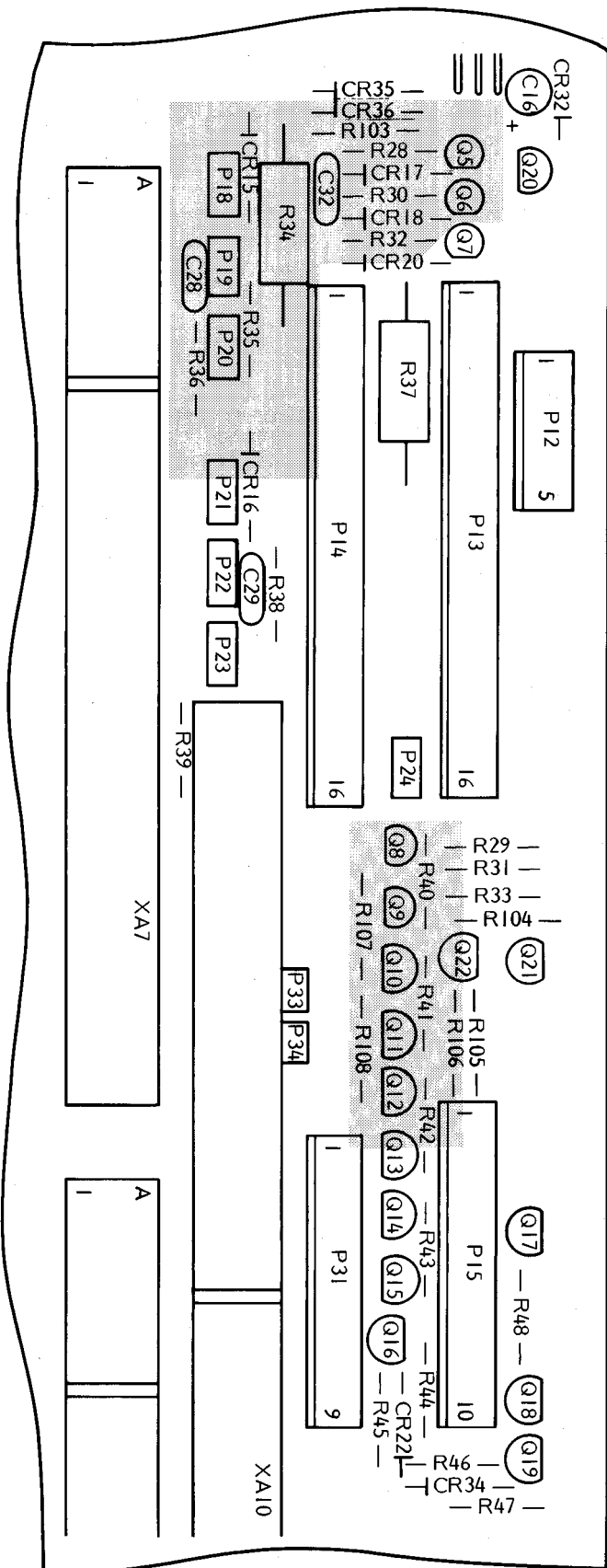

Osc 1 YIG, PIN Drive, and PIN/Modulator Parts Locator Diagram

A
B
C
D
E
F
G
H

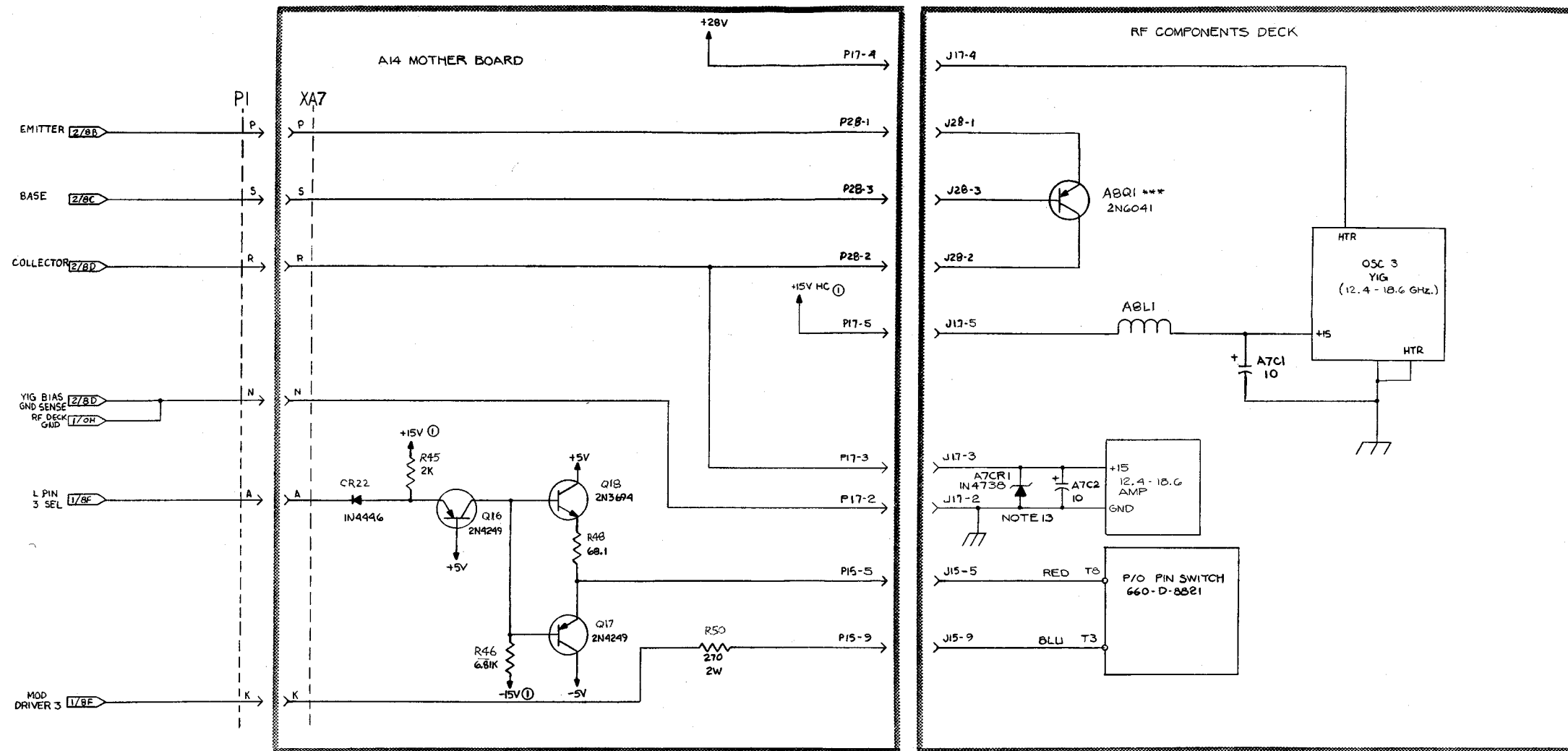

SEE SHEET 1 FOR NOTES

Figure 7-82A. A8 YIG Driver PCB, Assy. 660-D-8009-15, -16 Schematic (Sheet 3 of 3)

MANUAL CHANGES (Continued)

▶17. Page 7-199, paragraph 7-15.2

- a. Change heading to read "A14 Motherboard PCB, Wire Lists and Service Data and Rear Panel Wiring Diagram."
- b. To the listing introduced by the words, "This paragraph contains the following service data," add the following:
 - A rear panel drawing showing the wiring of the Voltage Selector Module, BNC connectors, and AUX I/O connectors.

18. Page 7-227, Figure 7-125

Remove and replace with revised Figure 7-125A, following.

▶19. Following Page 7-227/7-228

Add page 7-227A/7-228A, following.

REV F
OR
REV G

A14

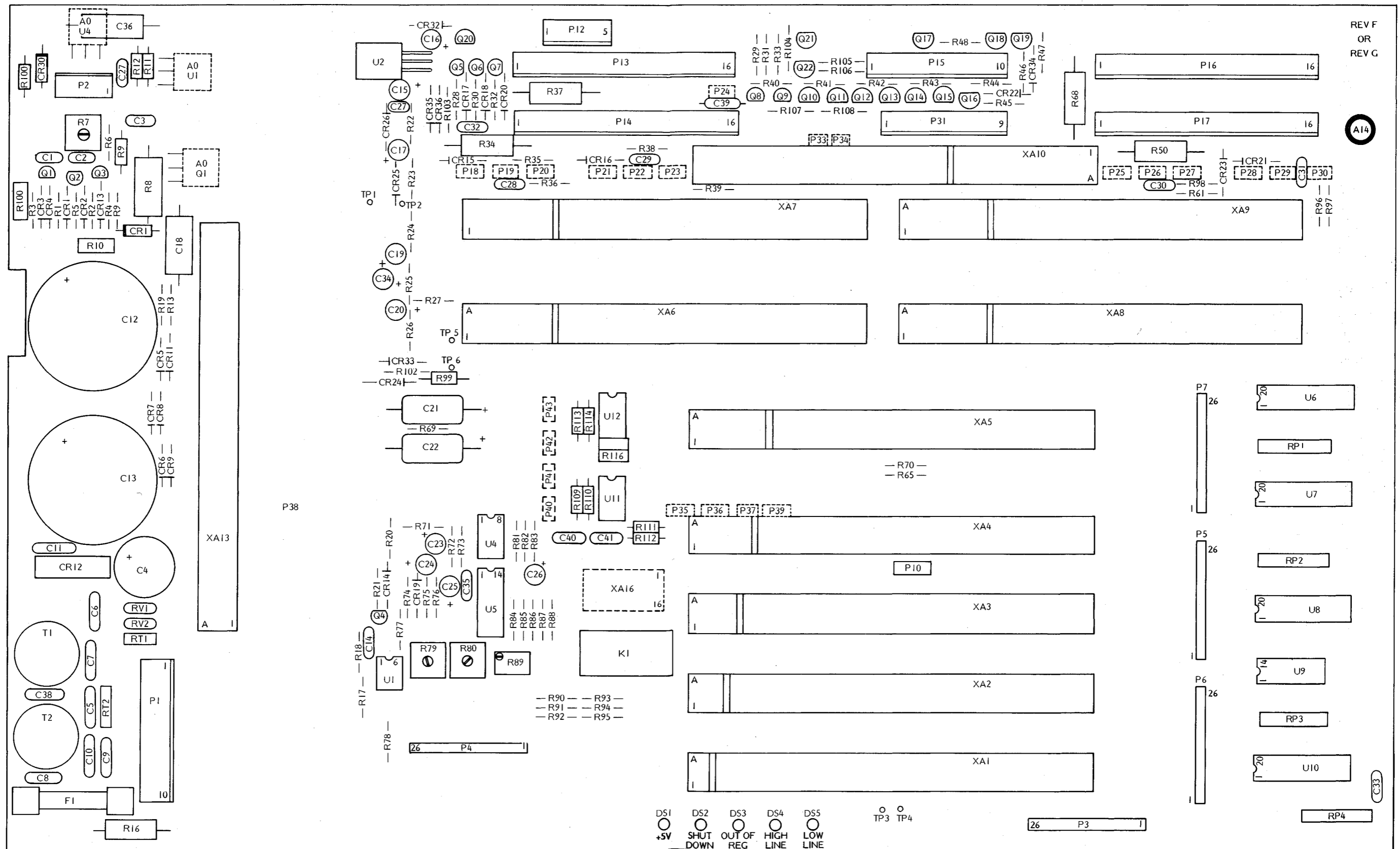

Figure 7-125. A14 Motherboard PCB Parts Locator Diagram

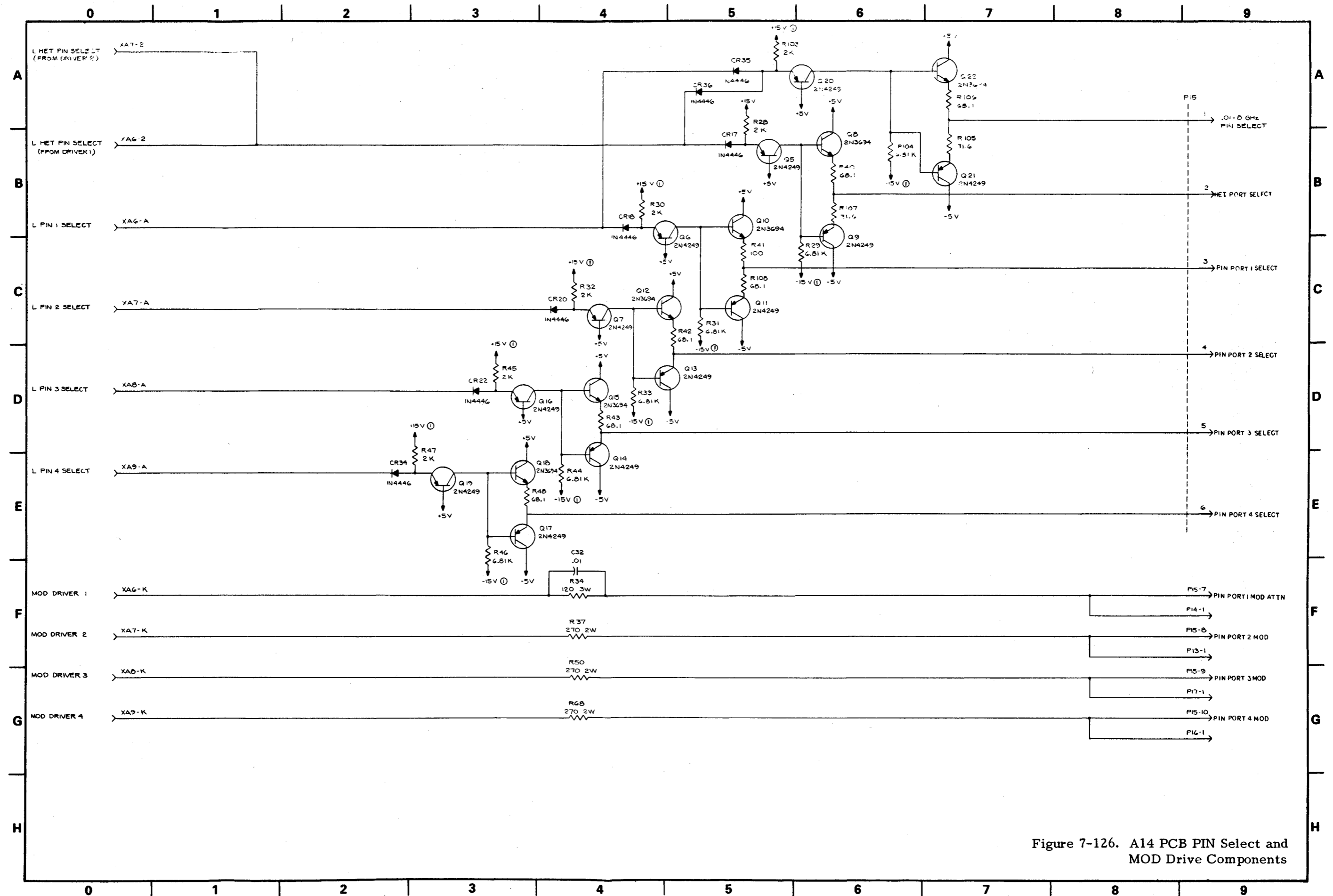

Figure 7-126. A14 PCB PIN Select and MOD Drive Components

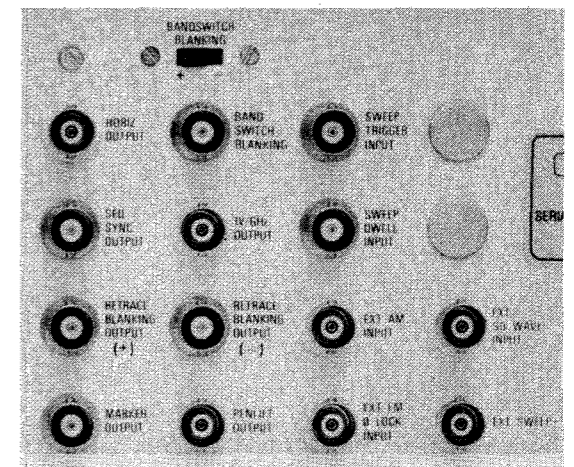
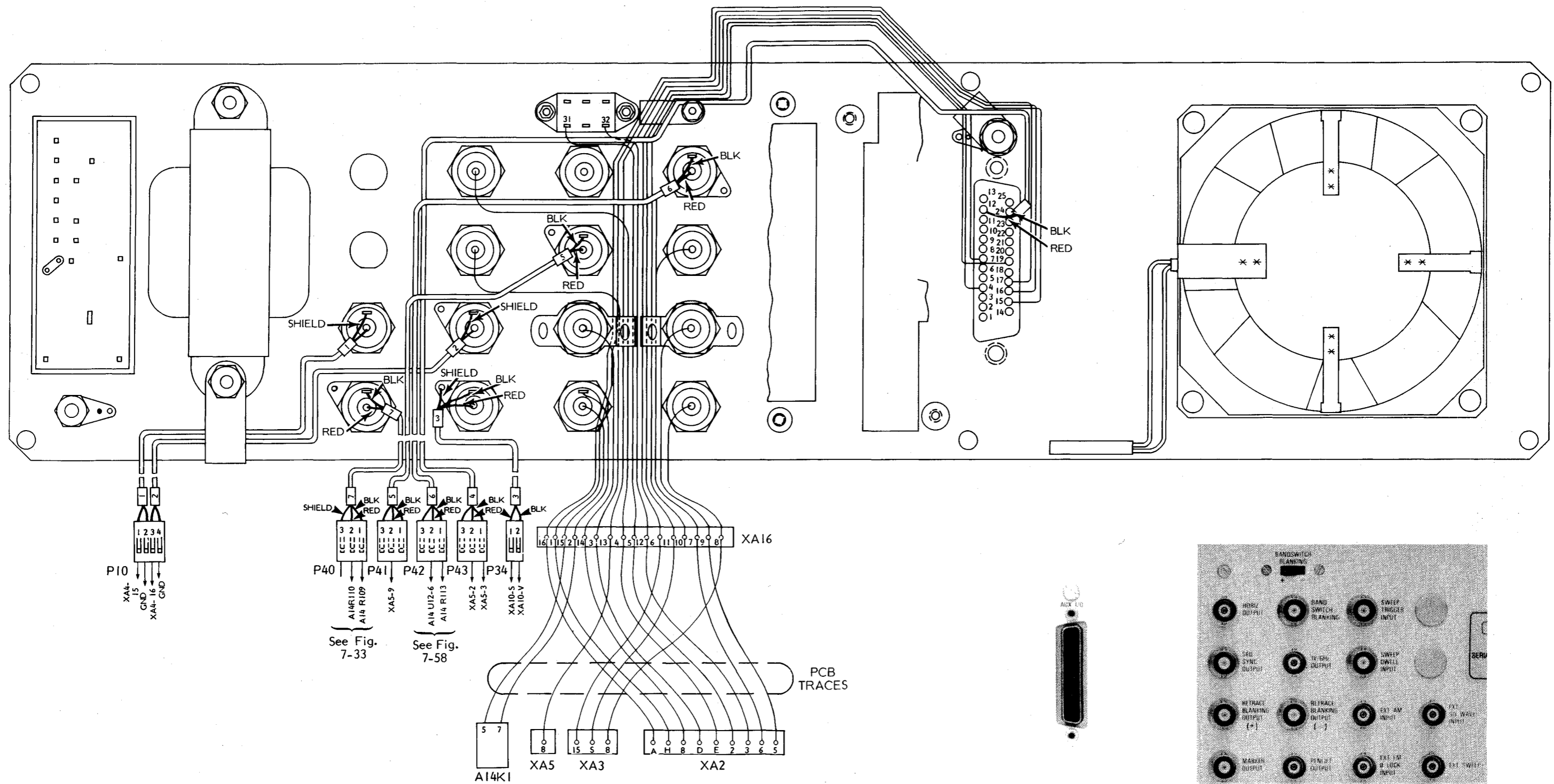

Figure 7-126A. Rear Panel Wiring (Sheet 1 of 2)

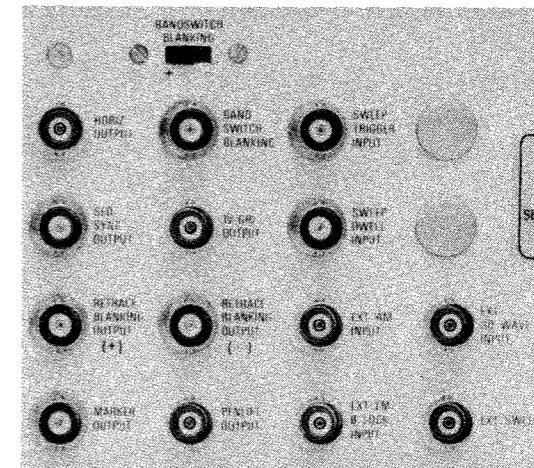
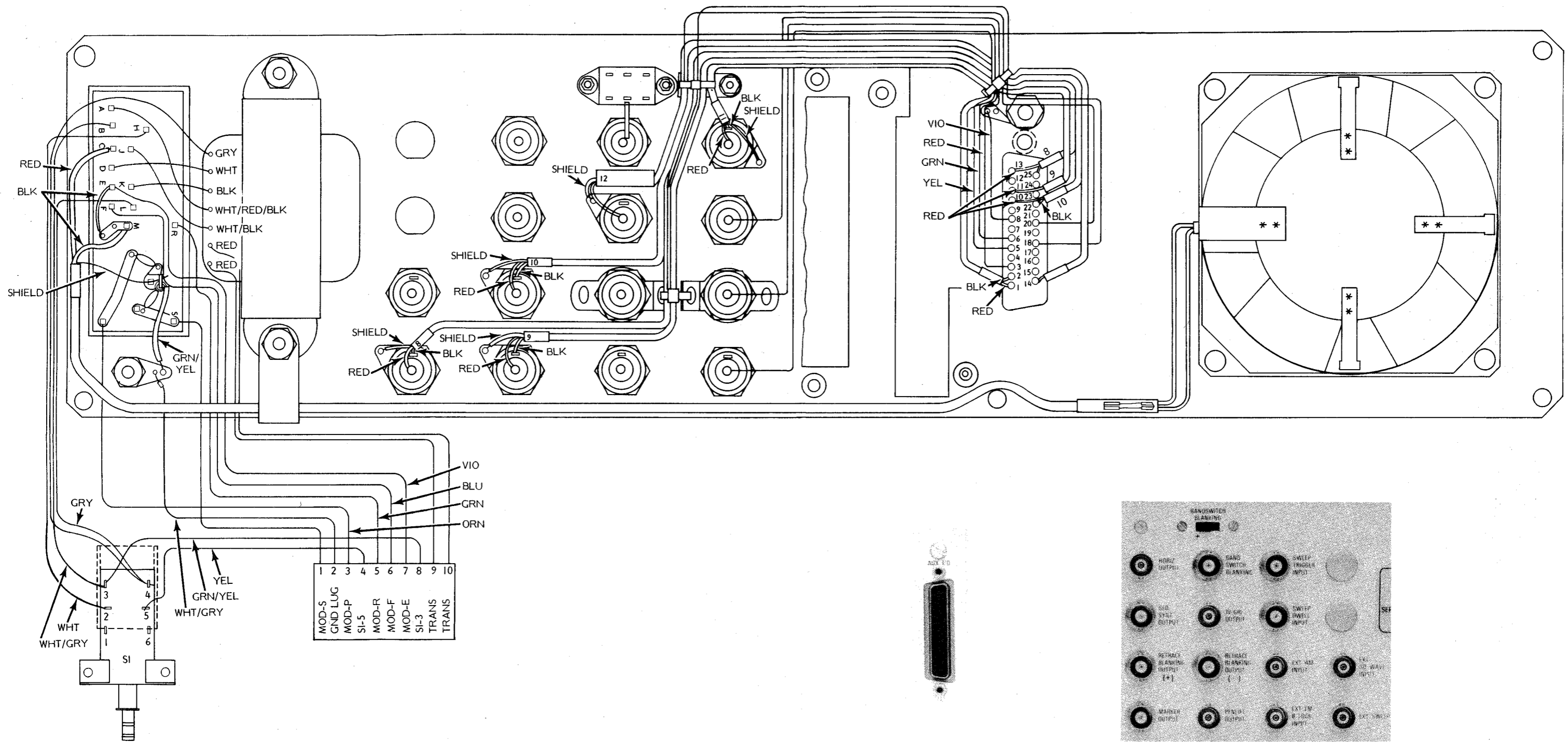

Figure 7-126B. Rear Panel Wiring (Sheet 2 of 2)

MANUAL CHANGES (Continued)

CHANGE #1 MODELS AFFECTED: All
 BASIC FRAME SN: 210001 and up

Page 6-50, Table 6-24, "CAPACITORS" Grouping

Change to read:

REF. DES.	DESCRIPTION	WILTRON PART NO.
C9	Disc, Ceramic, 3 kV, 0.0047 μ F	250-97
C10	Disc, Ceramic, 3 kV, 0.0047 μ F	250-97

PCO 2569 8/82

CHANGE #2 MODELS AFFECTED: All
 RF DECK SN: All

1. Pages 6-23 thru 6-32, Tables 6-6, 6-7, 6-8, 6-9, 6-11, and 6-12

Change "CAPACITORS" grouping to read:

REF DES	DESCRIPTION	WILTRON PART NO.
C9	Mylar, 0.01 μ F	227-50
C18	Mylar, 0.01 μ F	227-50
C23	Mylar, 0.01 μ F	227-50
C24	Mylar, 0.01 μ F	227-50
C25	Mylar, 0.01 μ F	227-50

2. Pages 6-29 thru 6-42, Tables 6-10, 6-13, 6-14, 6-15, 6-16, 6-17, 6-18, and 6-19

Change "CAPACITORS" grouping to read:

REF. DES.	DESCRIPTION	WILTRON PART NO.
C4	Mylar, 0.01 μ F	227-50
C14	Mylar, 0.01 μ F	227-50
C17	Mylar, 0.01 μ F	227-50
C18	Mylar, 0.01 μ F	227-50
C19	Mylar, 0.01 μ F	227-50

PCO 2577 9/82

MANUAL CHANGES (Continued)

CHANGE #3

MODELS AND SERIAL

NUMBERS AFFECTED: 6637A-40, 202001 & up
6647A-40, 201001 & up

1. Page 6-36, Table 6-14, "RESISTORS" Grouping

Change to read:

REF. DES.	DESCRIPTION	WILTRON PART NO.
R67 ¹	MF, 1/4W, 1%, <u>511</u>	110-511-1
R67 ²	MF, 1/4W, 1%, <u>511</u>	110- <u>511</u> -1

2. Page 7-154, Figure 7-77

In the resistor matrix, change the value of "R67" to read "511."

PCO 2581 8/82

CHANGE #4

MODELS AFFECTED: All
BASIC FRAME SN: 208001 & up

1. Page 5-9, paragraph 5-6

- a. Step a.3.: Change "A5TP3" to "A5TP10."
- b. Step b.3.: Change "A5TP3" to "A5TP10" in two places.

2. Page 7-110, Figure 7-58

Change the schematic as shown below.

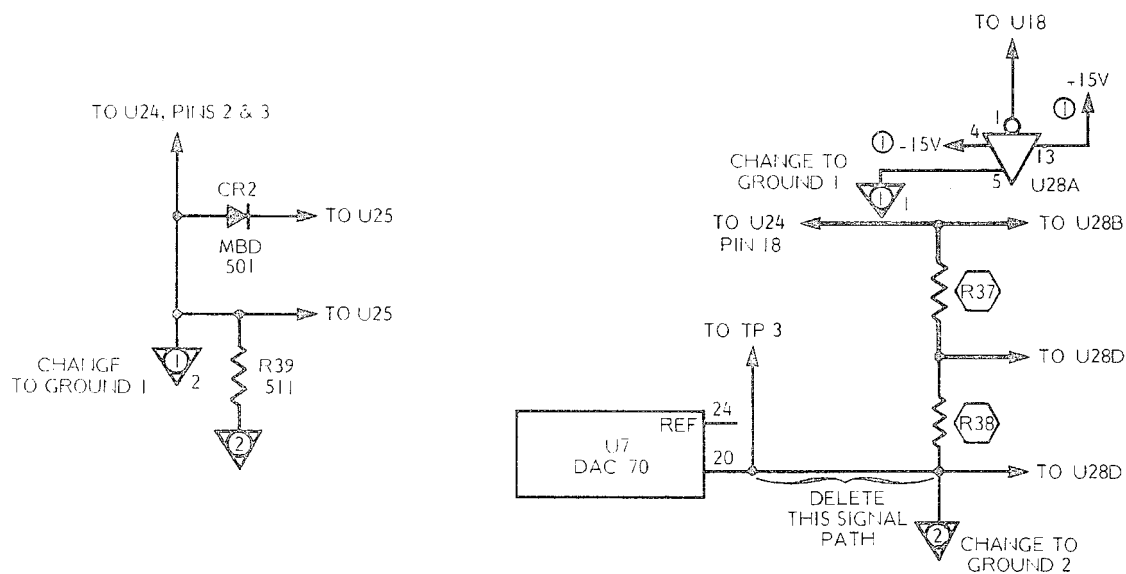

PCO 2596 9/82

MANUAL CHANGES (Continued)

CHANGE #5 **MODELS AFFECTED:** 6637A, 6637A-40, 6647A, 6647A-40, 6653A, 6659A
RF DECK SN: All

1. Page 6-11, Index No. 4b

Change part number to 320-63.

2. Page 6-13, Index No. 15b

Change part number to 320-63.

PCO 2599 10/82

CHANGE #6 **MODEL AFFECTED:** 6609A
RF DECK SN: 203001 & up

1. Page 6-10, Figure 6-5

Add to the parts list:

INDEX NO.	NAME	PART NO.
--	Filter (6609A)	1030-26

2. Page 7-95, Figure 7-48

Add a block labeled "LP FILTER" as shown below.

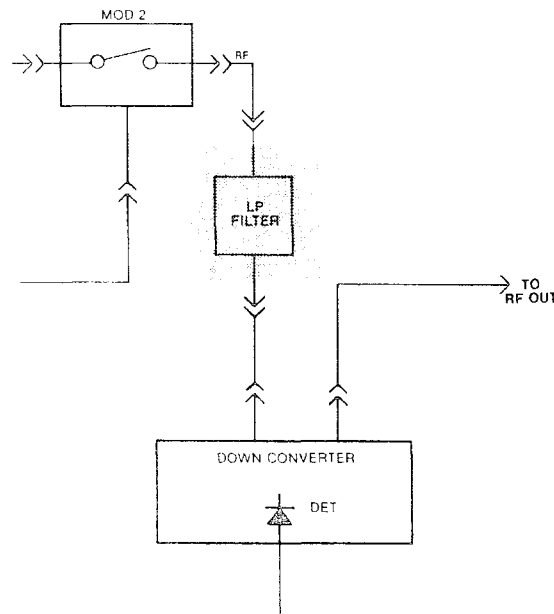

MANUAL CHANGES (Continued)

3. Page 7-184, Figure 7-94

Add a block labeled "LP FILTER" as shown below.

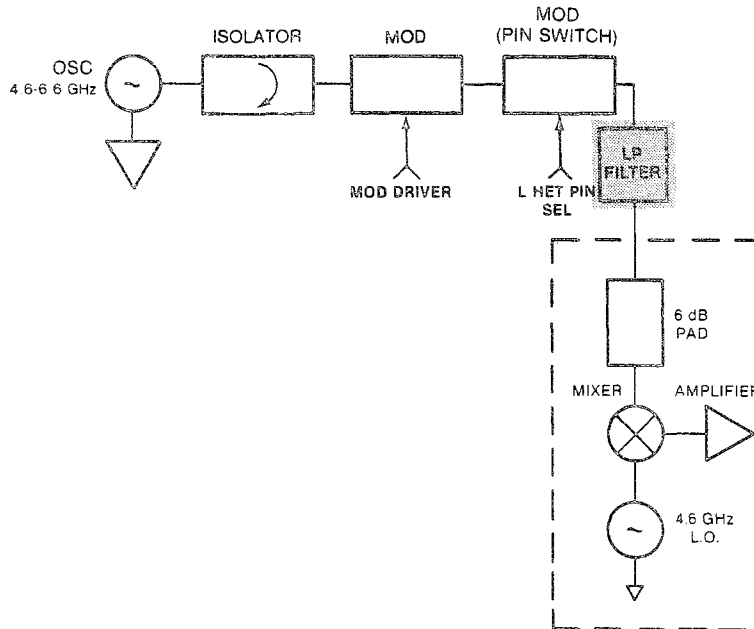

PCO 2656 12/82

CHANGE #7

MODELS AFFECTED: All
BASIC FRAME SN: 319001 & up

1. Pages 6-20 and 6-21, Table 6-4

Change to read:

REF DES.	DESCRIPTION	WILTRON PART NO.
CAPACITORS		
C26	Ceramic Disc, 0.1 μ F	230-37
RESISTORS		
R6	Variable, Multiturn, 10 k Ω	156-10k
R7	MF, 1/4W, 1%, 64.9 k Ω	110-64.9k-1
R12	Variable, Multiturn, 10 k Ω	156-10k
R13	MF, 1/4W, 1%, 64.9 k Ω	110-64.9k-1

MANUAL CHANGES (Continued)

R116	MF, 1/4W, 1%, 8.25 k Ω	110-8.25k-1
R149	MF, 1/4W, 1%, 8.25 k Ω	110-8.25k-1

2. Page 7-84, Paragraph 7-11.1

Change the 4th paragraph to read:

"The A4 PCB leveling circuit (Figure 7-43) provides overall control of the RF output power. The A4 PCB has two preamplifiers for internal leveling, U4 and U6. U4 is for the .01 to 2 GHz Het Band and U6 is for the >2 GHz YIG bands. Both U4 and U6 are differential amplifiers that remove any common-mode noise between the 'IN' and 'RTN' inputs. Potentiometers R12 and R6 in the respective U4 and U6 'RTN' inputs aid in cancelling 100 MHz sidebands in the 6636 single band model. These sidebands are not usually a problem in the other models."

3. Page 7-85, Figure 7-43

Add a potentiometer to the "RTN" input of the "INT PREAMP," as shown below.

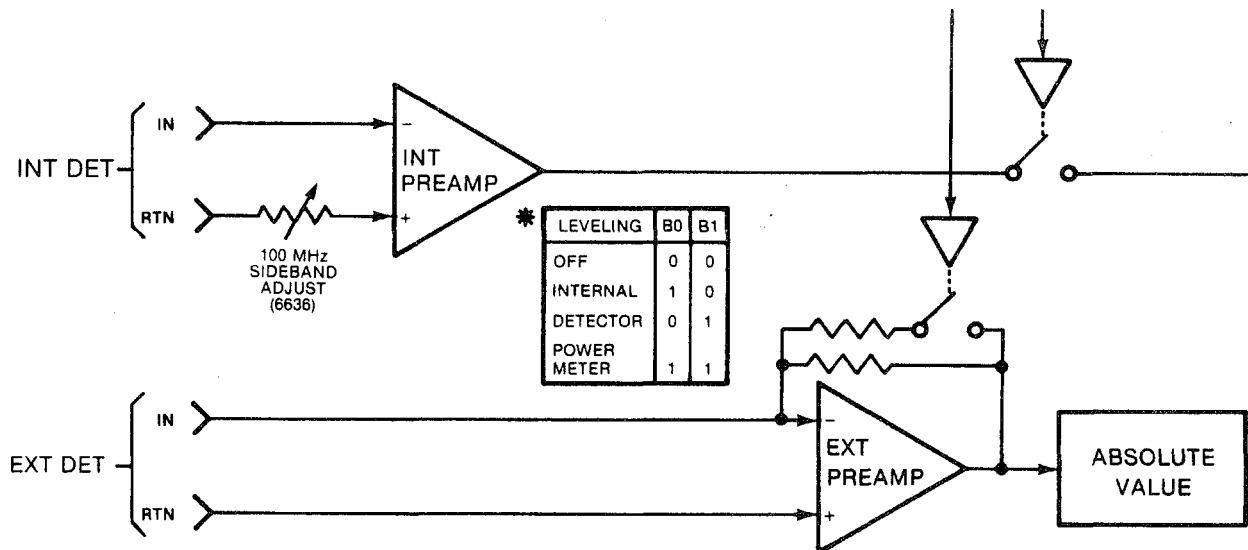

MANUAL CHANGES (Continued)

4. Page 7-86, Figure 7-44, Sheet 1, Coordinates 1C

Change the "DETECTOR RTN" inputs circuits on U4 and U6 as shown below.

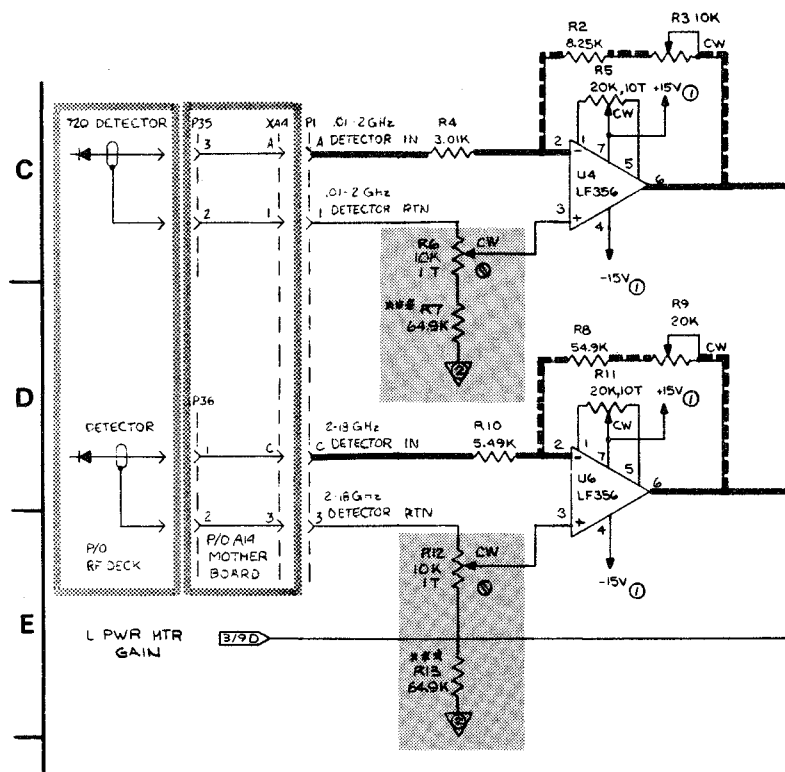

MANUAL CHANGES (Continued)

5. Page 7-88, Figure 7-44, Sheet 3, Coordinates 3A

Change the value on R116 and add C26 and R149 as shown below.

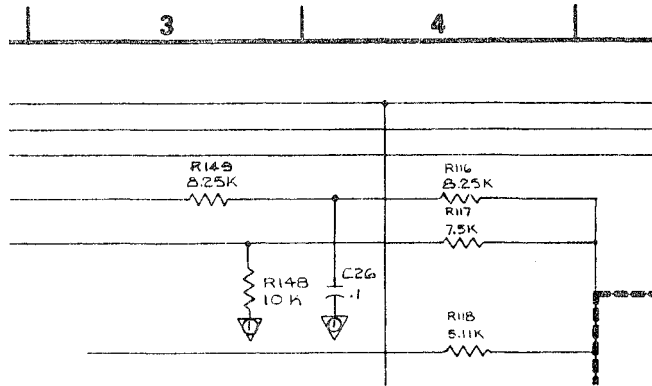

PCO 2668 11/82

CHANGE #8 **MODELS AFFECTED: All**
BASIC FRAME SN: 311001 thru 312040

1. Page 6-19, Table 6-3, "RESISTORS" Grouping

Change to read:

REF DES.	DESCRIPTION	WILTRON PART NO.
R17	MF, 1/4W, 1%, 261 kΩ	110-261k-1
R18	MF, 1/4W, 1%, 261 kΩ	110-261k-1
R24	MF, 1/4W, 1%, 261 kΩ	110-261k-1
R25	MF, 1/4W, 1%, 261 kΩ	110-261k-1
R31	MF, 1/4W, 1%, 261 kΩ	110-261k-1
R32	MF, 1/4W, 1%, 261 kΩ	110-261k-1
R58	MF, 1/4W, 1%, 30.1 kΩ	110-30.1k-1
R60	MF, 1/4W, 1%, 2.49 kΩ	110-2.49k-1

TECO G914 1/83

CHANGE #9 **MODELS AFFECTED: 6609A-50, 6617A-40, 6647A-40**
RF DECK SN: All

Instructions for updating the manual to cover the three affected models are listed in Change Addendum #1, which follows this change notice.

MANUAL CHANGES (Continued)

CHANGE #10

MODEL AFFECTED: 6609A
RF DECK SN: 303004 & up

1. Page 5-21, paragraph 5-8.2c

a. Change step 1 to read:

"For all models except 6609A, 6629A, 6629A-40, and 6642A:"

b. Add the following between steps 1.(a) and 2:

"1a. For the 6609A, connect multimeter as described in step 1(a) above. Adjust A6R47 for 5 ±0.2 Vdc."

2. Page 5-24, paragraph 5-9d

In step 4: 3rd line, change the words in parentheses to read "(A6R87 for 6609A)."

3. Page 6-23, Table 6-6

Delete this table entirely. The 660-D-8007-4 assembly has been replaced by the 660-D-8008-8 assembly, Table 6-15.

4. Pages 6-37 and 6-38, Table 6-15

a. Change the caption to read "A6, A7, A8 YIG Driver PCB, 6609A/6629A/6637A/6638A/6647A/6648A (660-D-8008-4, -7, -8, -99-90)."

b. Add:

REF DES.	DESCRIPTION	WILTRON PART NO.
<u>CAPACITORS</u>		
C20	Disc, Ceramic, .01 µF	230-11
<u>RESISTORS</u>		
R87	MF, 1/4W, 9.53 kΩ	110-9.53k-1
R88	MF, 1/4W, 1 kΩ	110-1k-1

5. Page 7-114, Table 7-17, 2nd row

Change the entry in the first column to read "660-D-8008-8."

6. Pages 7-128 thru 7-132

Remove and replace with revised pages 7-128 thru 7-132, following.

PCO 2634 11/82

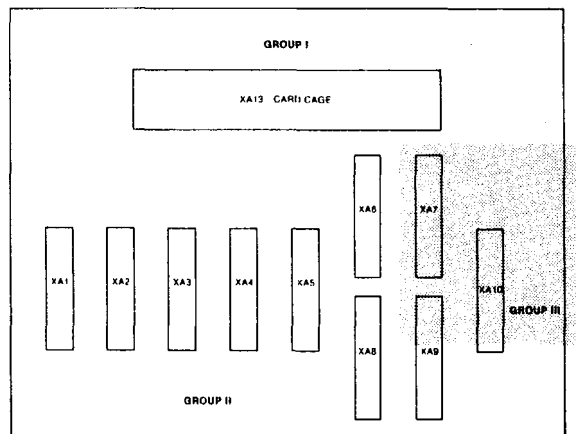
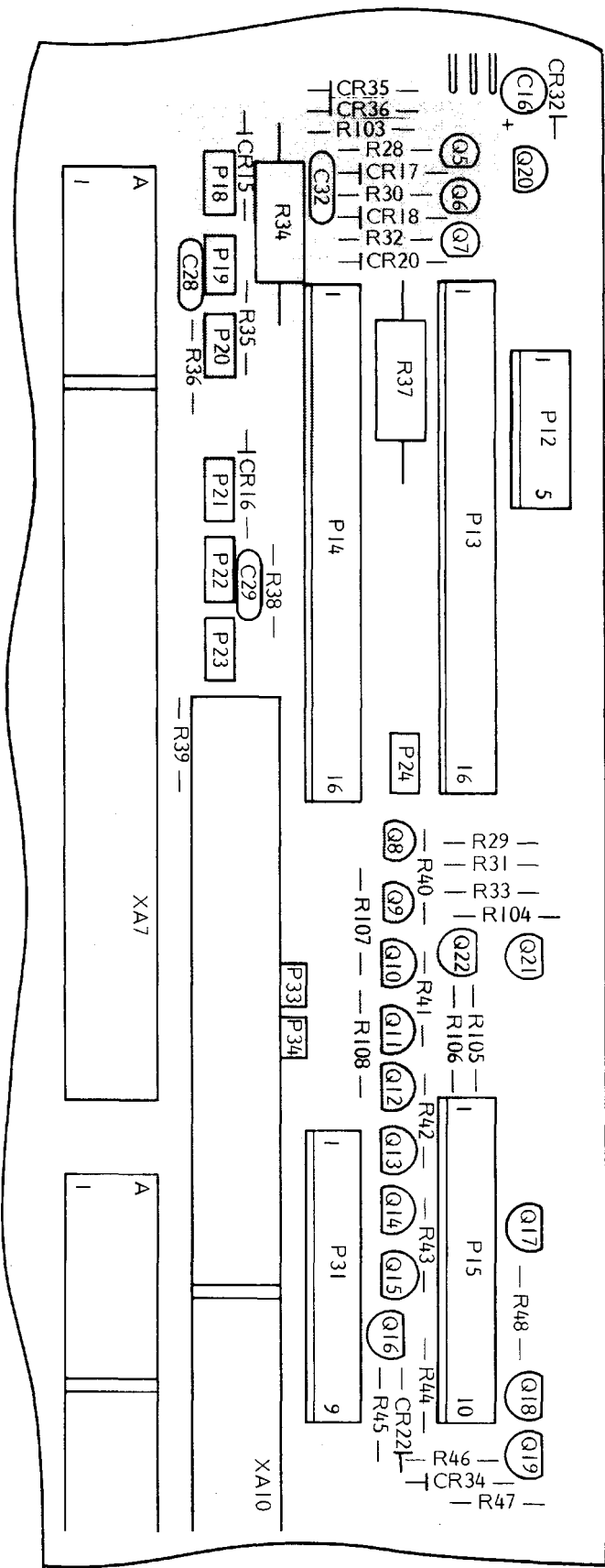

Osc 1 YIG, PIN Driver, and PIN/Modulator Parts Locator Diagram

7-12.4 Assy 660-D-8008-8 YIG Driver PCB, Circuit Description

The Het/YIG Driver PCB provides the drive current and bias voltage for the 4.61 to 6.6 GHz YIG oscillator, which is heterodyned with a 4.6 GHz fixed oscillator to generate the .01 to 2 GHz output frequency. The A6 PCB also provides the following:

- A modulating current for the MOD 1 (Modulator) component.
- A switching current for the MOD 2 (PIN Switch) component.
- Linearizing ROM output data. (A linearizing ROM, if installed, provides frequency correction data for making the frequency characteristics of the YIG oscillator linear.)

A block diagram for the YIG Driver PCB is shown in Figure 7-65. A simplified schematic of the E/I (voltage to current) Converter circuit is shown in Figure 7-66. And the PCB schematic (3 sheets) is provided in Figure 7-67.

The **F CEN**, $\Delta F > 50$ MHz, and **F CORR** signals generated on the A5 PCB are summed together at the E/I Converter (Figure 7-65) and used to generate the YIG tuning coil current. The output of this YIG is a sweeping frequency, 4.61 to 6.6 GHz. This sweeping output is applied to the Down Converter Assembly, where it is beat with a 4.6 GHz oscillator. The product, a sweep .01 to 2 GHz, is amplified and applied to the RF output circuit (paragraph 7-14).

As shown in Figure 7-66, the three A5 voltage signals – along with a heterodyne offset voltage via R87 – are applied to U3. The output from U3 controls the current through the YIG tuning coil, via transistor A6Q2 (located on the RF Deck). (-38V is applied to the emitter of A6Q2 via A6Q3, which is used as a voltage switch in other 6600A Series models.) The current through the YIG coil develops a proportional voltage drop across sense resistor (R SENSE) R25.

The remaining input to the E/I Converter is the **CW FILTER** line. When the microproc-

essor commands that the CW filter be inserted, relay K1 is activated. (The CW filter is inserted when the sweep width is ≤ 50 MHz or when a CW mode has been selected from the front panel.) When K1 is activated, the R23-C10 network creates an alternate negative-feedback path around the YIG oscillator. This path reduces the noise current flowing through the coil; thereby quieting the YIG oscillator frequency output.

As shown in Figure 7-65, the voltage developed across R25 provides the input for the A7 Sweeping Bias Supply. This circuit is not used with the 6609A.

The inputs to U2C, the PIN Switch control gate, are the **L RF OFF** and **L PIN SW OFF** lines from the A4 PCB and the **H YIG SEL** line from the Bandswitch Logic. When all three of these inputs are HIGH, the **L PIN SELECT** line is TRUE. The **RF OFF** line is HIGH when the front panel RF ON switch is depressed (On). The **PIN SW OFF** line is HIGH during the forward sweep and goes LOW at the start of the sweep retrace (provided RETRACE RF is not On). The **YIG SEL** line is always HIGH.

When the **L PIN SELECT** line is FALSE, it reverse-biases A14CR18 (Figure 7-67, Sheet 3). Reverse-biasing CR18 causes A14Q6 to turn on, A14Q10 to turn on, and A14Q11 to turn off. When on, Q10 sources current into the MOD (PIN Switch).

Conversely, when the **L PIN SELECT** line is TRUE, CR18 is forward-biased. Forward-biasing CR18 causes Q6 to turn off, Q10 to turn off, and Q11 to turn on. When on, Q11 sinks current from the MOD (PIN Switch).

Sourcing current into MOD 2 (PIN Switch) effectively opens the RF output circuit. Conversely, sinking current from the switch closes the circuit. This switch is used to apply square-wave modulation to the RF output energy.

The inputs to the Linearizer ROM (U5) are the **ROM Bus** lines from the microprocessor, via the A14U6 latch on the motherboard. The Linearizer ROM is enabled by the TRUE state of the **L ROM SEL** line from the

Bandswitch Logic circuit. This ROM outputs eight bits of data to the A5 PCB. This circuitry is not presently used with the 6609A.

The input to the PIN Driver/Linearizer (U4A, U4B, Q3, Q4) is the **PIN MOD DRIVER** voltage signal from the A4 PCB. This circuit has two functions: (1) It provides the ALC-loop-gain adjustment, and (2) it makes linear the relationship between the A4 PCB Level Amp output in Vdc (paragraph 7-11.1) and the RF power output in dBm. The output from this circuit is a current: **MOD DRIVER**. This current is supplied to MOD 1 on the RF Deck, via A14R34 (Figure 7-67, Sheet 3).

The input to the -5V Bias Supply (U1B, U7C, Q5, Q7) is the control line, **L RF OFF**. When the front panel RF ON switch is disengaged (out), the microprocessor sets this line TRUE. When **L RF OFF** is TRUE, the -5V Bias Supply is turned off, thus turning off the YIG oscillator.

The Bandswitch/ROM Select Logic circuit (U8A-U8D), along with its input comparators U9A and U9B, provide bandswitching voltages in multiband models using two or more YIG oscillators. In the 6609A, this circuit is configured such that the **H SNB** and **H SNR** output lines are always FALSE, and the **H YIG SEL** and **L YIG SEL** output lines are always TRUE.

(U1B, U7C, OFF. When disengaged line TRUE. e -5V Bias off the YIG

logic circuit comparators ing voltages r more YIG s circuit is and H SNR and the H at lines are

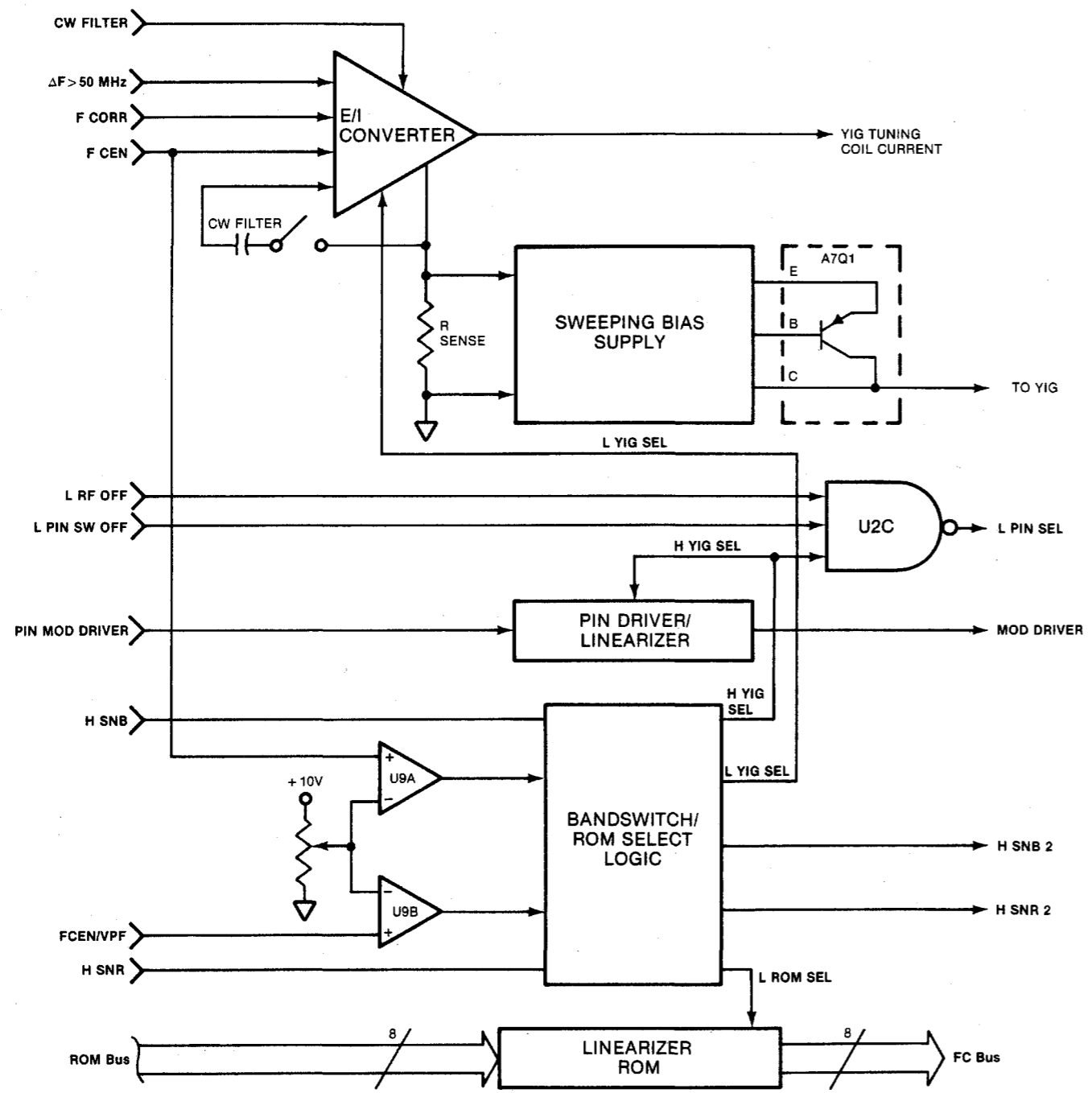

Figure 7-65. A6 YIG Driver PCB (Assy 660-D-8008-8) Block Diagram

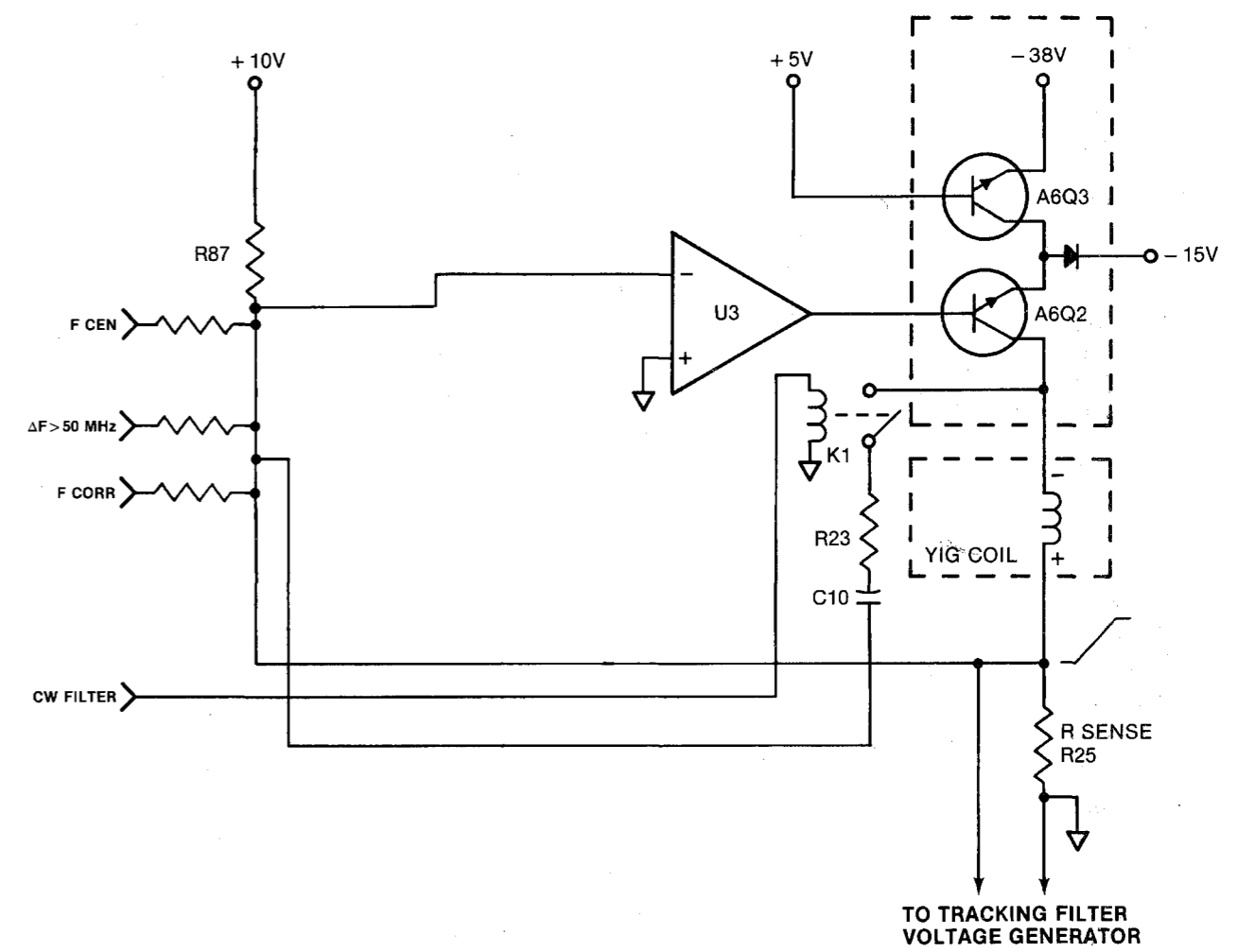
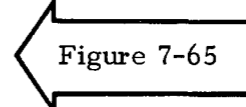
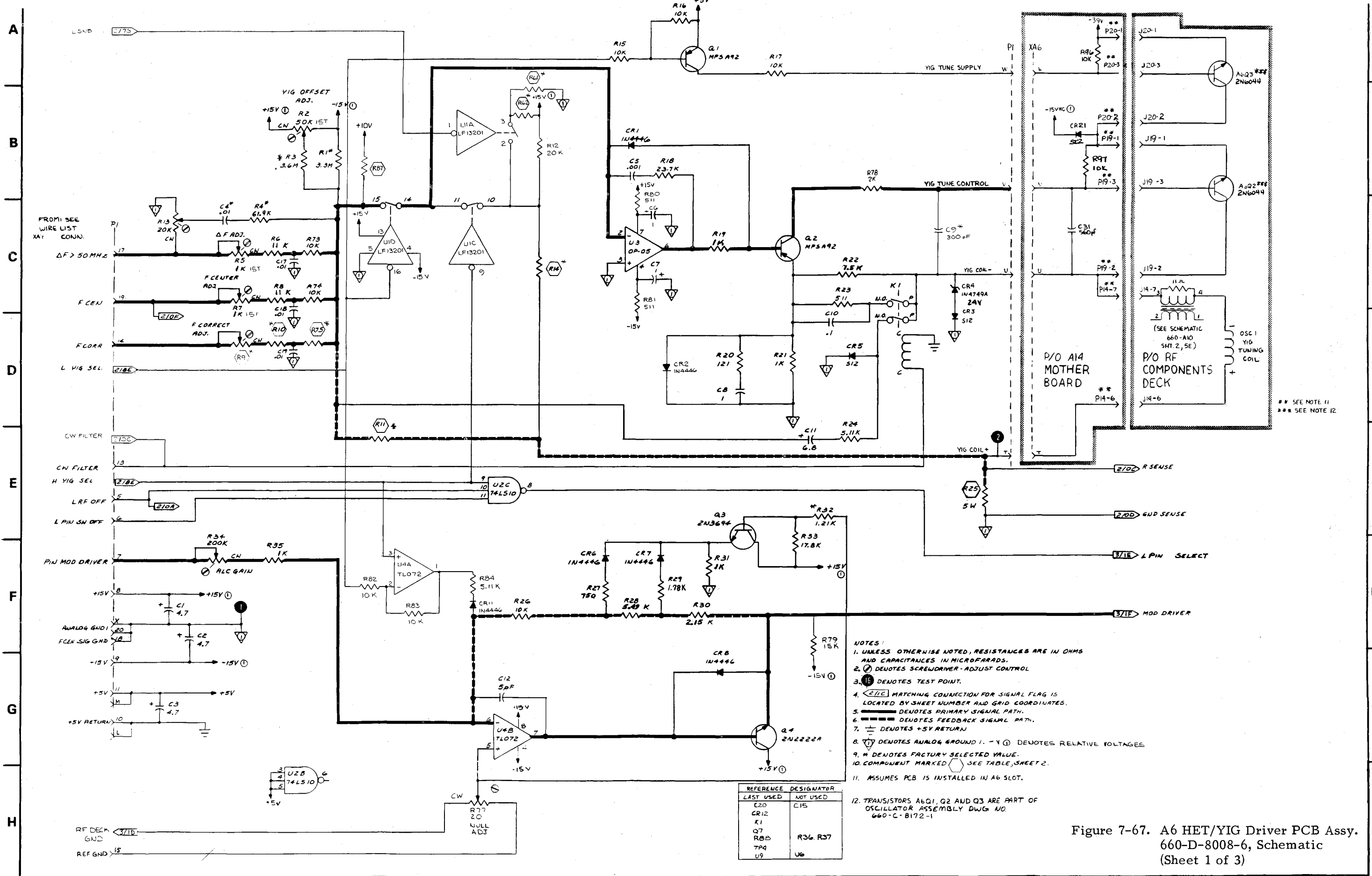

Figure 7-66. Assy. 8008-8 E/I Converter Simplified Schematic





- NOTES:
1. UNLESS OTHERWISE NOTED, RESISTANCES ARE IN OHMS AND CAPACITANCES IN MICROFARADS.
 2. Ⓢ DENOTES SCREWDRIVER-ADJUST CONTROL
 3. Ⓢ DENOTES TEST POINT.
 4. Ⓢ MATCHING CONNECTION FOR SIGNAL FLAG IS LOCATED BY SHEET NUMBER AND GRID COORDINATES.
 5. — DENOTES PRIMARY SIGNAL PATH.
 6. - - - DENOTES FEEDBACK SIGNAL PATH.
 7. ⊕ DENOTES +5V RETURN
 8. Ⓢ DENOTES ANALOG GROUND 1. -Y ⊕ DENOTES RELATIVE VOLTAGES
 9. * DENOTES FACTORY SELECTED VALUE.
 10. COMPONENT MARKED Ⓢ SEE TABLE, SHEET 2.
 11. ASSUMES PCB IS INSTALLED IN A6 SLOT.
 12. TRANSISTORS A6Q1, Q2 AND Q3 ARE PART OF OSCILLATOR ASSEMBLY DWG. NO. 660-C-8172-1

REFERENCE DESIGNATOR	
LAST USED	NOT USED
C20	C15
CR12	
K1	
Q7	R36, R37
R8D	
TPA	
U9	U6

Figure 7-67. A6 HET/YIG Driver PCB Assy. 660-D-8008-6, Schematic (Sheet 1 of 3)

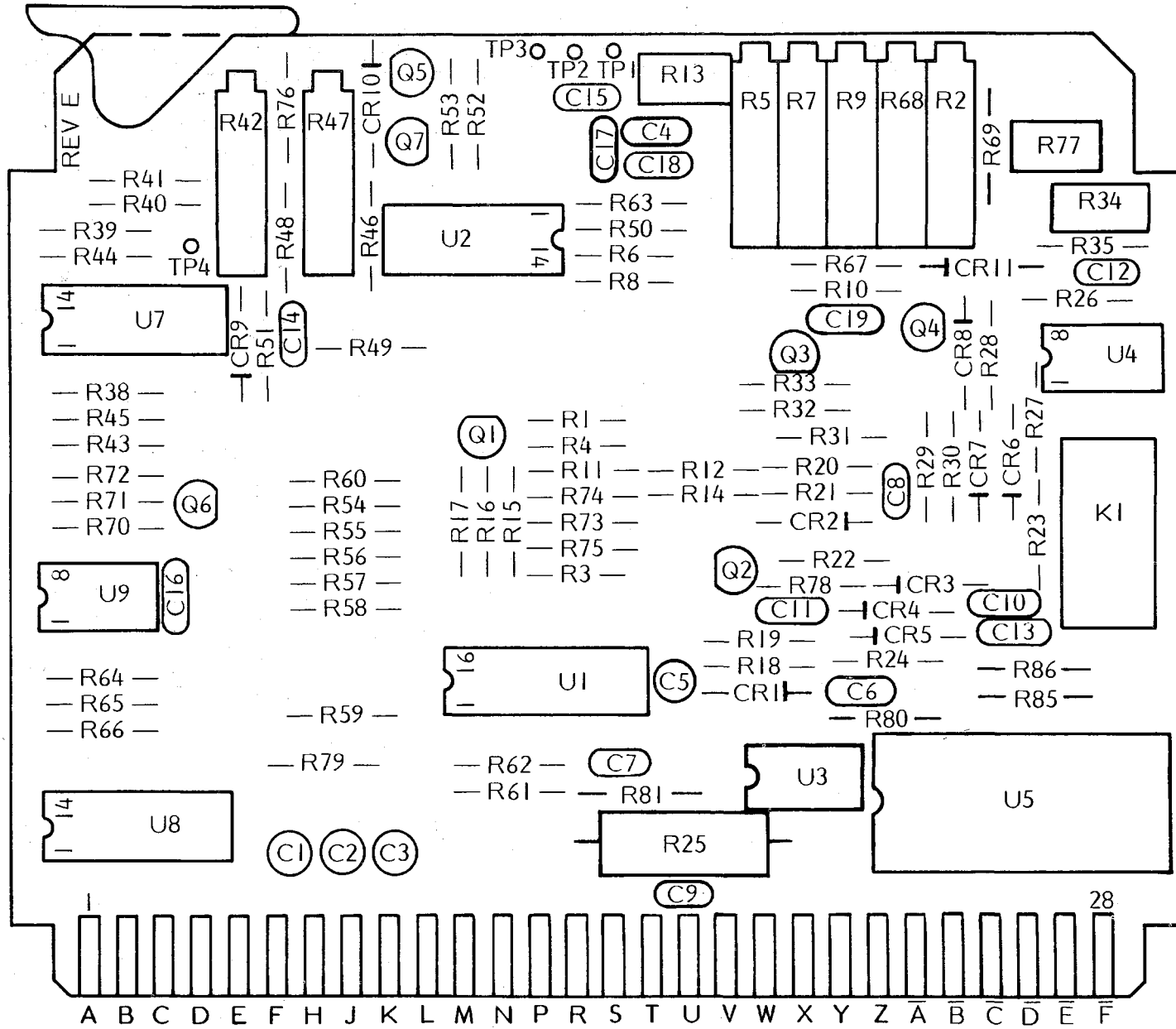

A6 PCB Parts Locator Diagram

Figure 7-67
(Sheet 1 of 3)

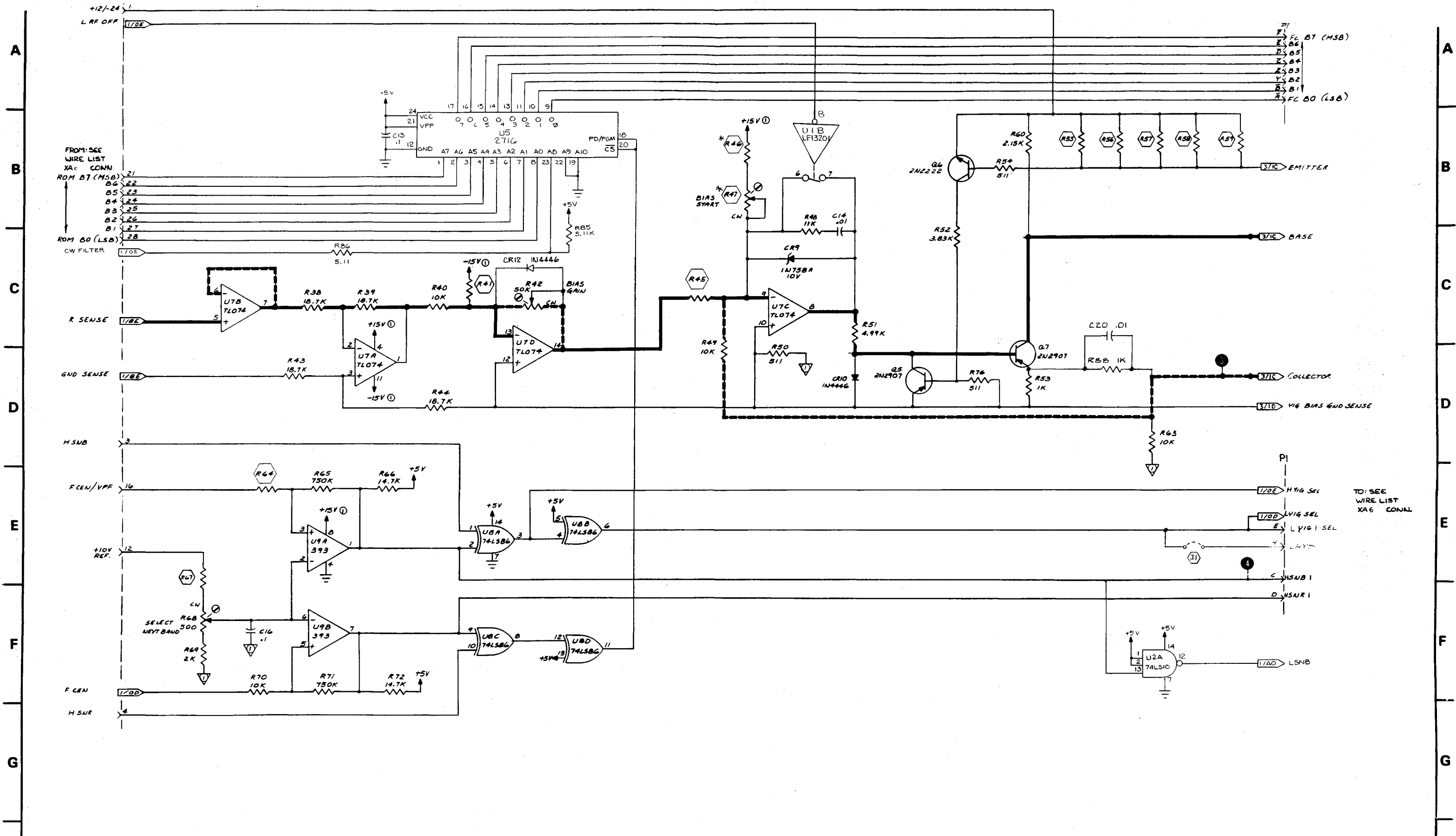

R11	R14	R41	R45	R55, R56	R57-59	R61	R62	R67	R46	R47	R64	R25	R9	R10	R75	R67	J1
3.57K	1.53K	—	—	5.11	—	110K	—	—	24.9K	10K	—	5.2	50K	78.7K	76.8K	9.53K	INSTALLED

Figure 7-67. A6 HET/YIG Driver PCB Assy. 660-D-8008-6, Schematic (Sheet 2 of 3)

A
B
C
D
E
F
G
H

A
B
C
D
E
F
G
H

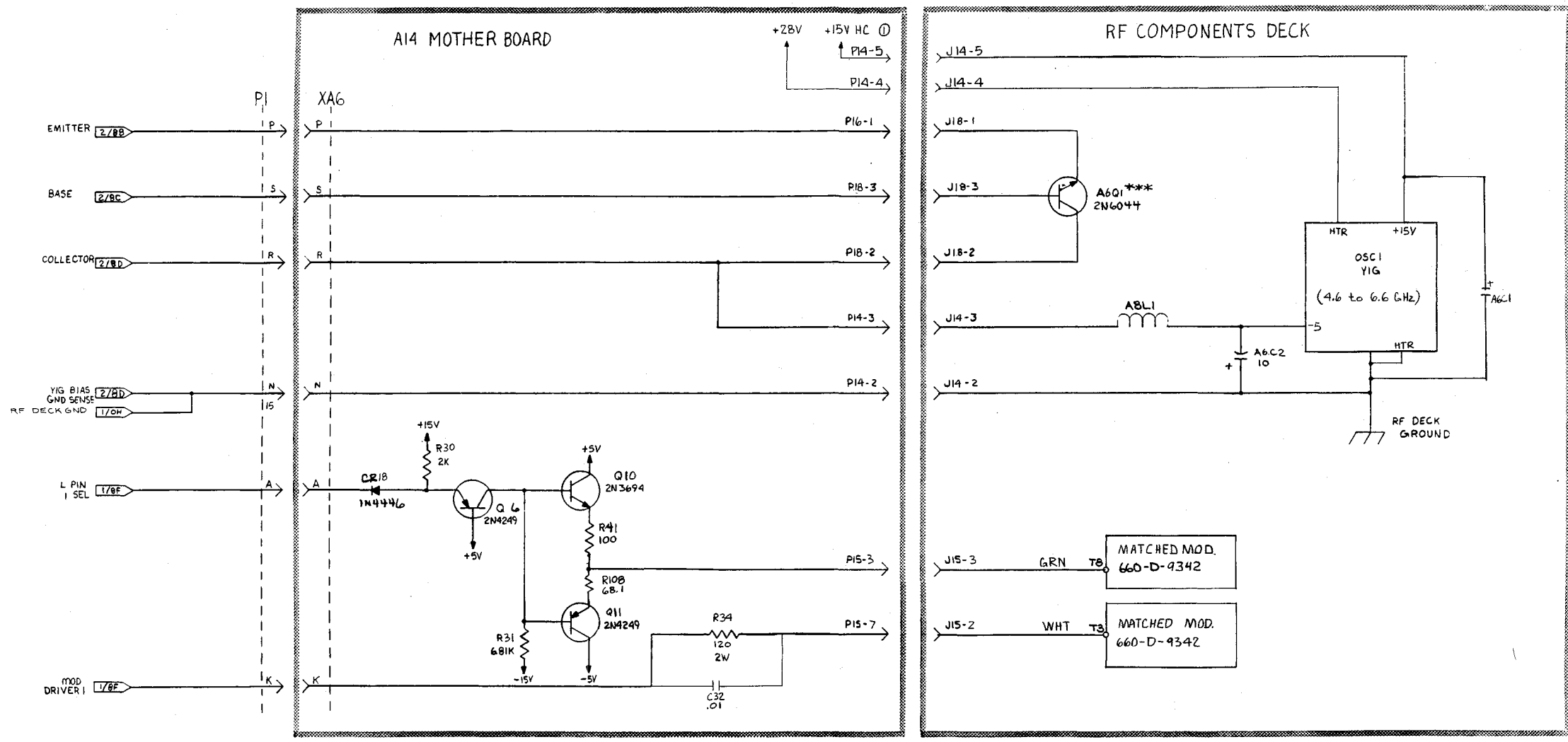

SEE SHEET 1 FOR NOTES

Figure 7-67. A6 HET/YIG Driver PCB Assy.
660-D-8008-6, Schematic
(Sheet 3 of 3)

0 1 2 3 4 5 6 7 8 9

MANUAL CHANGES (Continued)

CHANGE #11

MODELS AFFECTED: All
BASIC FRAME SN: 312001 & up

1. Page 5-8, paragraph 5-5b

Delete steps 8 thru 12 and the "NOTE."

2. Pages 5-9 and 5-10, paragraph 5-6

Perform the following steps a. thru b.3., then proceed to page 5-10 and continue the procedure with step c.

a. Bandswitch Reference Voltage Adjustment

1. Set up the test equipment as shown in Figure 5-8 and turn the equipment on.

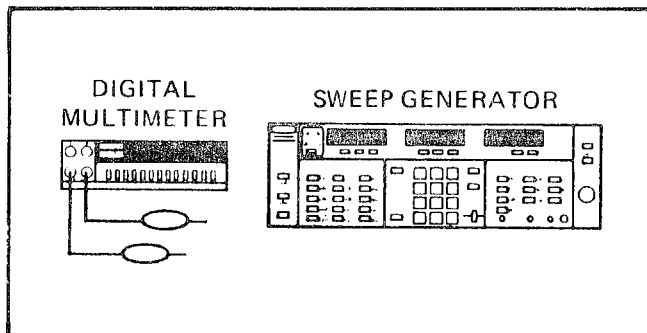

Figure 5-8. Setup for A5 Frequency Instruction Adjustments

2. Remove the top cover from the sweep generator (sweeper). Refer to paragraph 7-3.1 for instructions, if necessary.
3. Connect the common lead on the digital multimeter (DMM) to A5TP10 (Figure 5-9) and the test lead to A5TP9.
4. Adjust A5R55 for +10V ± 1.0 mV.
5. Move the DMM test lead to A5TP8 and adjust A5R49 for -10 ± 1.0 mV.

b. Sweep Width (ΔF) Signal Path Adjustments

1. Press RESET.
2. Press SHIFT, then EXT SWEEP.
3. Remove the DMM leads from A5TP8 and A5TP10. Connect a BNC-to-clip-lead jumper between the rear panel EXT SWEEP connector and A5TP9 and A5TP10 (center conductor to A5TP9).
4. Connect the DMM test lead to A5TP5 and the common lead to A5TP10. Note the voltage level at A5TP5.
5. Disconnect the BNC connector from EXT SWEEP; note the voltage value at A5TP5.
6. Alternately connect and disconnect the BNC connector at the EXT SWEEP connector, and adjust A5R29 for equal TP5 voltages ± 1.0 mV. Record both voltage values.
7. Press MANUAL SWEEP, and rotate its associated control fully clockwise.
8. Adjust A5R69 for the "-" voltage value recorded in step 6 ± 1.0 mV.
9. Rotate the MANUAL SWEEP control fully counterclockwise, and verify that the "+" voltage at A5TP5 is the same as that recorded in step 6 ± 25.0 mV.

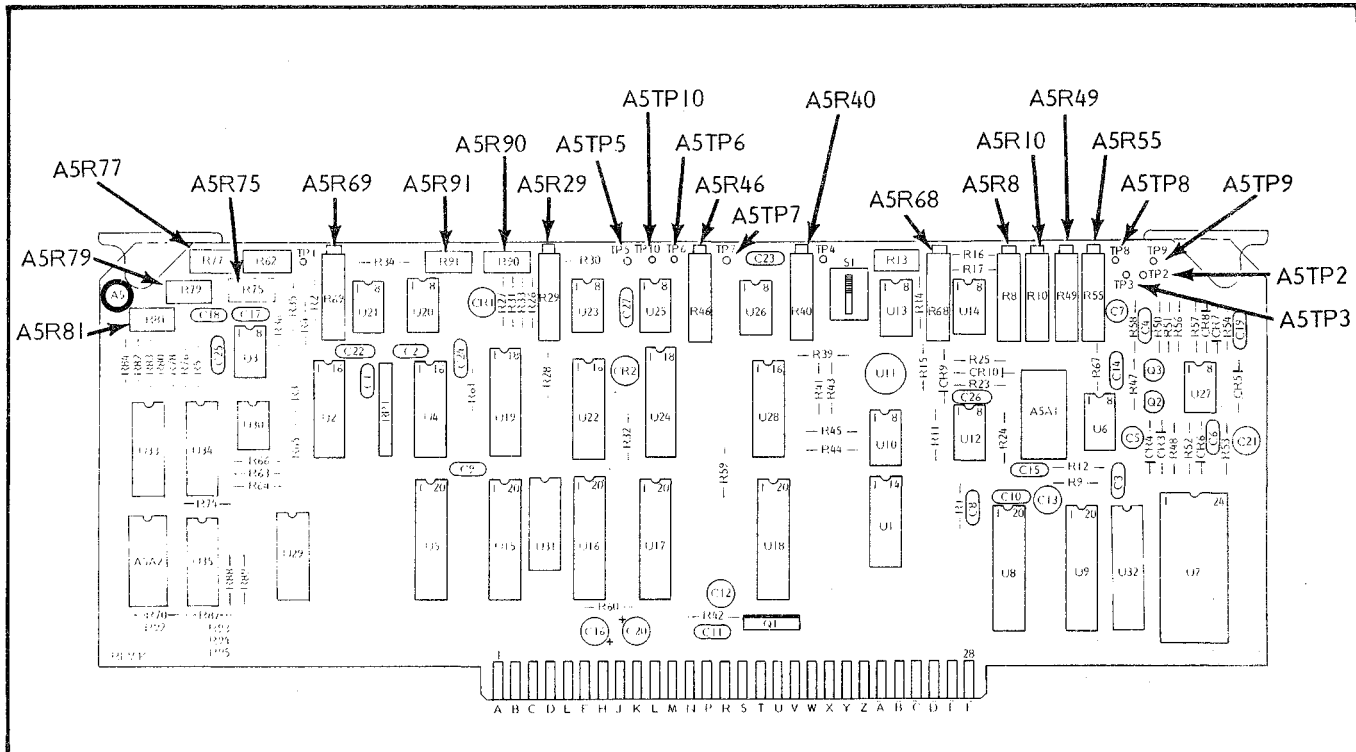

Figure 5-9. A5 Frequency Instruction Adjustments

10. Remove the BNC connector from the EXT SWEEP connector.
 11. Press SHIFT, then EXT SWEEP.
 12. Move the DMM test lead to A5TP6.
 13. Connect a jumper between A5TP5 and A5TP10.
 14. Press ΔF F0.
 15. Press ΔF and set for 0 MHz.
 16. Adjust A5R46 for $0V \pm 1.0$ mV.
 17. Move the DMM test lead to A5TP7.
 18. Adjust A5R40 for $0V \pm 1.0$ mV.
 19. Remove the jumper from between A5TP5 and A5TP10.
- b.1. Step DAC Output-Voltage Adjustment, Version 06 Software (Disregard this step if Option 3 is not installed)

NOTE

The two-digit software version number appears on the F1-F0-M1 LED display when the POWER pushbutton is pressed to on.

1. Connect the 85 Controller to the GPIB Interface.
2. On the 85, type OUTPUT 705; "FUL STP STS4095E". Press END LINE.

NOTE

The front panel GPIB REMOTE indicator should light.

3. Move the DMM test lead to A5TP5.
4. Adjust A5R90 for the "-" voltage value recorded in step b.6 ± 1.0 mV.
5. Press RETURN TO LOCAL.

b.2. Step DAC Output-Voltage Adjustment, Version 07 Software

1. Move the test lead to A5TP5.
2. Press SHIFT, then RF ON.
3. Adjust A5R90 for the "-" voltage value recorded in step b.6 ± 1.0 mV.
4. Press SHIFT to return the front panel to normal operation.

b.3. Ramp Output Adjustments

1. Connect the DVM to the rear panel HORIZ OUTPUT connector.

2. Ground the center conductor on the EXT SWEEP connector.
3. Rotate the MANUAL SWEEP control fully clockwise.
4. Press SHIFT, then EXT SWEEP.
5. Adjust A5R62 for $0V \pm 1.0$ mV.
6. Press MANUAL SWEEP and adjust A5R91 for $10V \pm 1.0$ mV.
7. Repeat steps 5 and 6 as necessary to obtain the $0V$ and $10V \pm 1.0$ mV values.

3. Page 6-22, Table 6-5, "RESISTORS" Grouping

1. Change to read:

REF DES.	DESCRIPTION	WILTRON PART NO.
"R26	MF, 1/4W, 1%, 9.09 k Ω	110-9.09k-1
R34	MF, 1/4W, 1%, 9.09 k Ω	110-9.09k-1"

2. Add:

R90	Variable, single turn, 2 k Ω	156-2k
R91	Variable, single turn, 2 k Ω	156-2k
R92	MF, 1/4W, 1%, 10 k Ω	110-10k-1
R93	MF, 1/4W, 1%, 10 k Ω	110-10k-1
R94	MF, 1/4W, 1%, 10 k Ω	110-10k-1
R95	MF, 1/4W, 1%, 10 k Ω	110-10k-1

4. Page 7-110, Figure 7-58

- a. Add R90 and R91, and change the value of R26 and R34, as shown below.

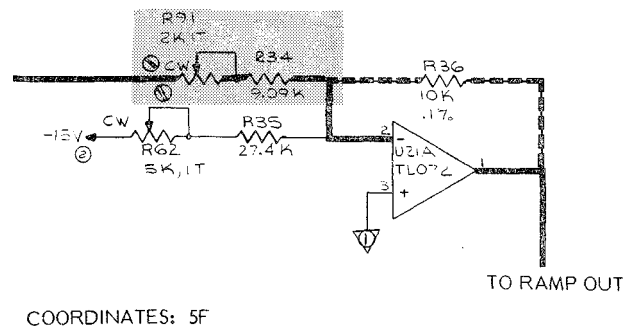
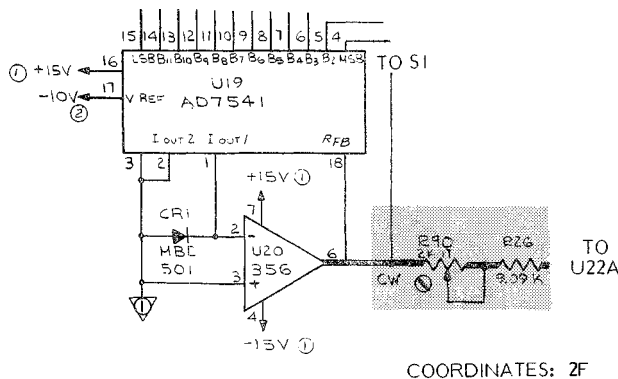

- b. Copy the following revised A5 PCB Parts Locator, and tape or glue it over the existing "A5 PCB Parts Locator Diagram."

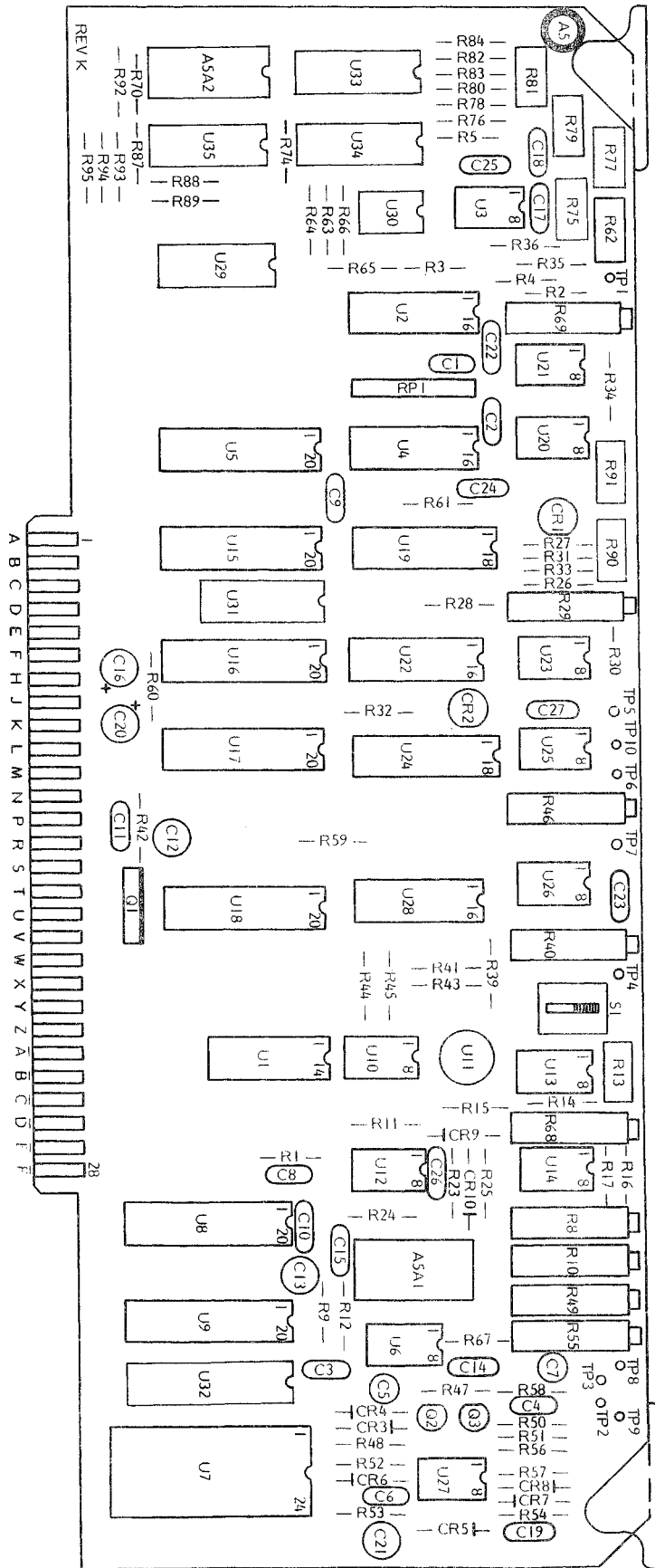

MANUAL CHANGES (Continued)

5. Page 7-111, Figure 7-58, Sheet 2

Add resistors R92 thru R95, as shown below:

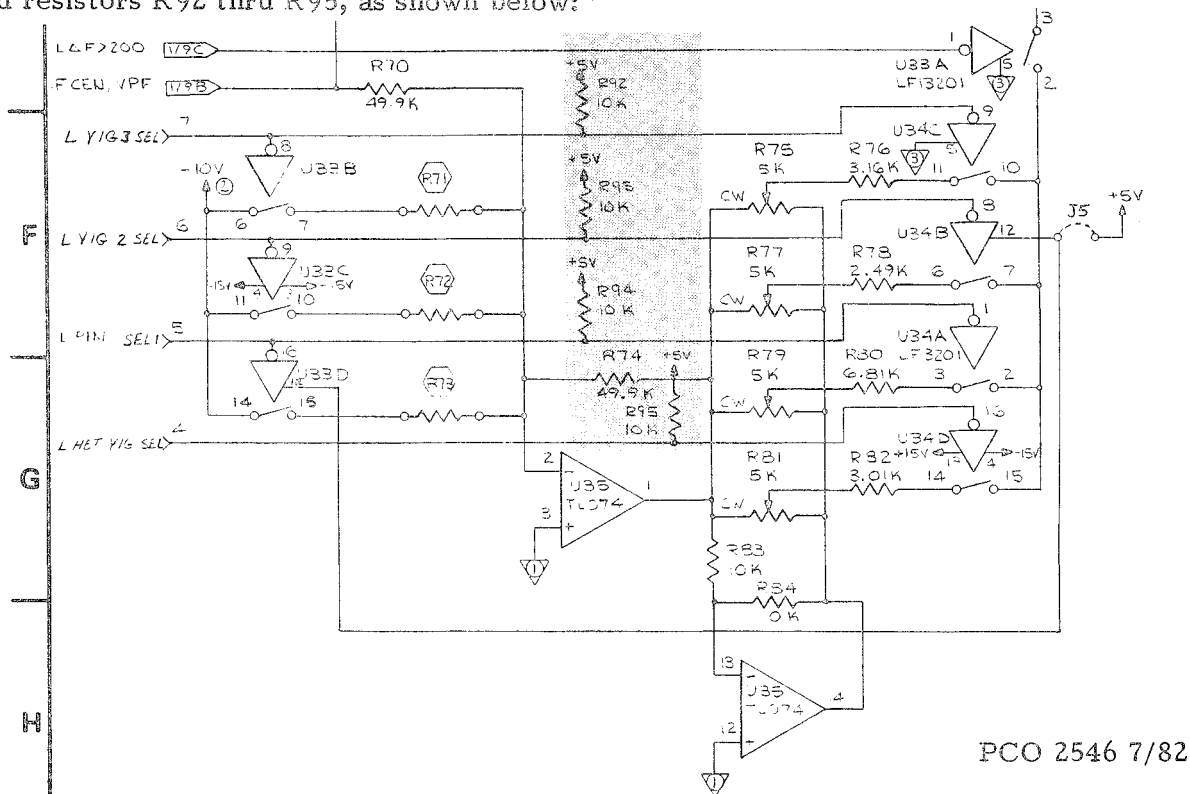

PCO 2546 7/82

CHANGE #12

MODELS AND SERIAL NUMBERS AFFECTED:

- 6621A, 316001 & up
- 6629A, 316001 & up
- 6637A, 316001 & up
- 6638A, 303001 & up
- 6647A, 316001 & up
- 6637A-40, 305001 & up
- 6647A-40, 305001 & up
- 6648A, 303001 & up
- 6653A, 307001 & up
- 6659A, 307001 & up

1. Pages 6-32 thru 6-43, Tables 6-12, 6-13, 6-14, 6-17, 6-18, and 6-19

Add:

REF DES.	DESCRIPTION	WILTRON PART NO.
<u>CAPACITORS</u>		
C21	Disc , Ceramic, .01 μ F	230-11
<u>RESISTORS</u>		
R88	MF, 1/4W, 1%, 1 k Ω	110-1k-1

MANUAL CHANGES (Continued)

2. Pages 7-157 thru 7-170, Figures 7-78 thru 7-82, Sheet 2

Add C21 and R88, as shown below.

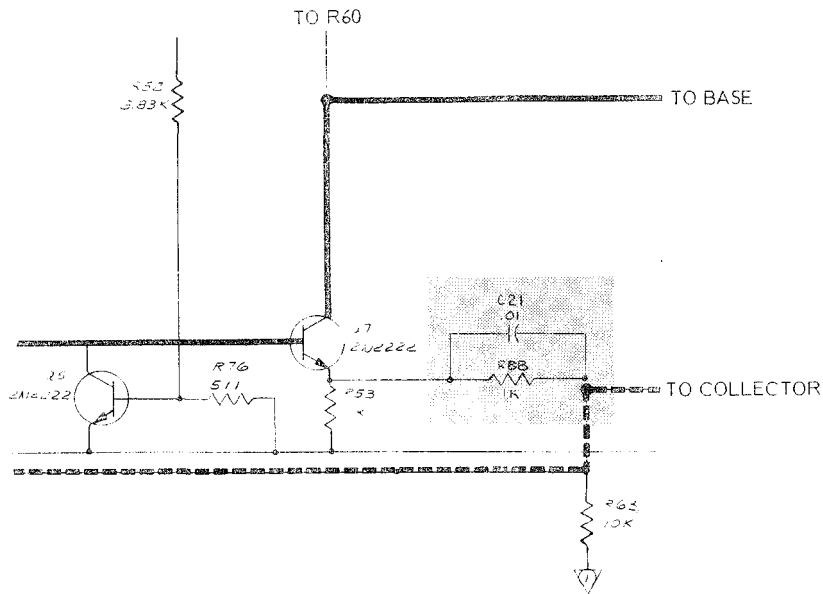

COORDINATES: 7D

PCO 2681 11/82

CHANGE #13

**MODELS AND SERIAL
NUMBERS AFFECTED:**

6629A, 316001 & up
6637A, 316001 & up
6638A, 303001 & up
6647A, 316001 & up
6648A, 303001 & up

1. Page 6-37, Table 6-15

Add:

REF DES.	DESCRIPTION	WILTRON PART NO.
<u>CAPACITORS</u>		
C20	Disc , Ceramic, .01 μ F	230-11
<u>RESISTORS</u>		
R88	MF, 1/4W, 1%, 1 k Ω	110-1k-1

2. Page 7-151, Figure 7-56, Sheet 2

Add C20 and R88, as shown below.

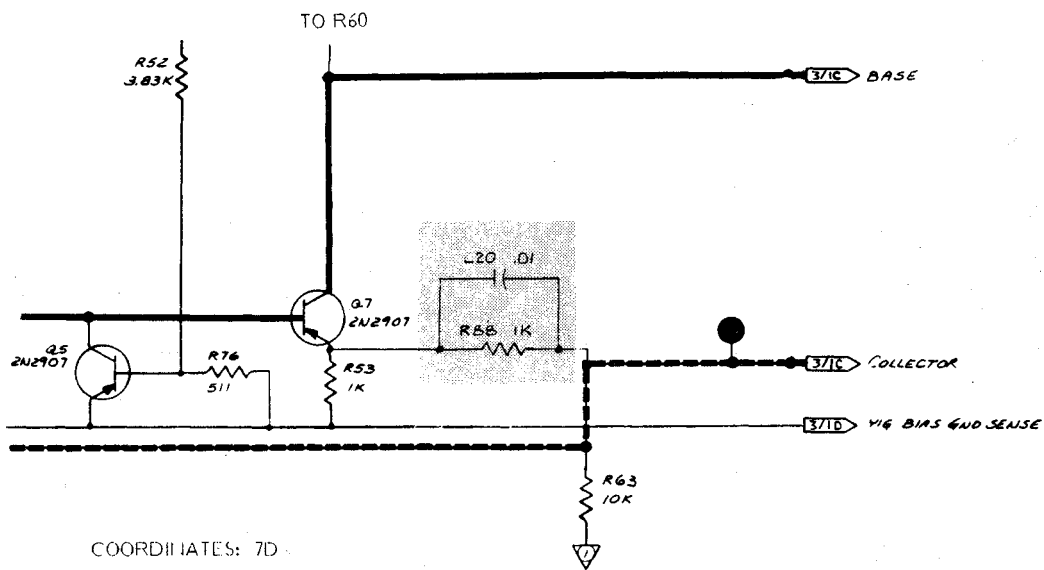

PCO 2680 11/82

MANUAL CHANGES (Continued)

CHANGE #14

**MODELS AND SERIAL
NUMBERS AFFECTED:**

6617A, 306001 & up
6617A-40, 300001
6637A, 315001 & up
6637A-40, 304001 & up
6638A, 306001 & up
6647A, 315001 & up
6647A-40, 304001 & up
6648A, 306001 & up
6653A, 306001 & up
6659A, 306001 & up

1. Pages 6-25 thru 6-28, 6-31, and 6-32; Tables 6-7 thru 6-9 and 6-11

Delete these tables, and replace them with Table 6-11A following.

2. Page 7-114, Table 7-17

Change as shown below.

YIG DRIVER ASSY NO.	PCB SLOT	YIG OSCILLATOR PART NO.	MODEL(S)	CIRCUIT DESCRIPTION PARAGRAPH NO.	SCHEMATIC FIG. NO.
660-D-8006-4	A6	1005-47	6637A, 6647A	7-12.3	7-62
660-D-8008-8	A6	1005-45	6609A	7-12.4	7-67
660-D-8006-8	A6	1005-47	6638A, 6648A	7-12.3	7-62
660-D-8006-7	A6	1005-47	6617A	7-12.3	7-62
660-D-8006-6	A6	1005-47	6653A, 6659A	7-12.3	7-62
660-D-8006-99-91	A6	1005-47	6621A	7-12.3	7-62
660-D-8190-99-96	A6	1005-35	6642A	7-12.6	7-73
660-D-8006-5	A6	1005-47	6637A-40	7-12.3	7-63
660-D-8006-5-99 -91	A6	1005-47	6621A-40	7-12.3	7-63

3. Pages 7-115 and 7-116, paragraph 7-12.3

a. Change the paragraph heading to read:

"Assy 660-D-8006-3, -4, -5, -6, -7, -8, and -99-91 Het/YIG Driver PCB, Circuit Description"

R55	MF, 1/4W, 1%, 750 kΩ	110-750k-1
R56	MF, 1/4W, 1%, 14.7 kΩ	110-14.7k-1
R57	MF, 1/4W, 1%, 5.11 kΩ	110-5.11k-1
R57	MF, 1/4W, 1%, 5.11 kΩ	110-5.11k-1
R57	MF, 1/4W, 1%, 2.74 kΩ	110-2.74k-1
R57	MF, 1/4W, 1%, 3.16 kΩ	110-3.16k-1
R57	MF, 1/4W, 1%, 976Ω	110-976-1
R58	Variable, 15-Turn, 500Ω	157-500
R59	MF, 1/4W, 1%, 2 kΩ	110-2k-1
R60	MF, 1/4W, 1%, 10 kΩ	110-10k-1
R61	MF, 1/4W, 1%, 750 kΩ	110-750k-1
R62	MF, 1/4W, 1%, 14.7 kΩ	110-14.7k-1
R63	MF, 1/4W, 1%, 27.4 kΩ	110-27.4k-1
R63	MF, 1/4W, 1%, 18.2 kΩ	110-18.2k-1
R63	MF, 1/4W, 1%, 20 kΩ	110-20k-1
R63	MF, 1/4W, 1%, 6.49 kΩ	110-6.49k-1
R64	MF, 1/4W, 1%, 2 kΩ	110-2k-1
R65	Variable, 15-Turn, 500Ω	157-500
R66	Variable, 1-Turn, 200 kΩ	156-200k
R67	MF, 1/4W, 1%, 20 kΩ	110-20k-1
R68	MF, 1/4W, 1%, 10 kΩ	110-10k-1
R69	MF, 1/4W, 1%, 10 kΩ	110-10k-1
R70	MF, 1/4W, 1%, 15 kΩ	110-15k-1
R71	MF, 1/4W, 1%, 1.30 kΩ	110-1.30k-1
R72	MF, 1/4W, 1%, 8.87 kΩ	110-8.87k-1
R73	MF, 1/4W, 1%, 3.40 kΩ	110-3.40k-1
R74	MF, 1/4W, 1%, 5.11 kΩ	110-5.11k-1
R75	MF, 1/4W, 1%, 301Ω	110-301-1
R76	MF, 1/4W, 1%, 1.21 kΩ	110-1.21k-1
R77	MF, 1/4W, 1%, 17.8 kΩ	110-17.8k-1
R78	MF, 1/4W, 1%, 511Ω	110-511-1
R79	MF, 1/4W, 1%, 10 kΩ	110-10k-1
R80	MF, 1/4W, 1%, 10 kΩ	110-10k-1
R81	MF, 1/4W, 1%, 205 kΩ	110-205k-1
R82	MF, 1/4W, 1%, 2 kΩ	110-2k-1
R83	MF, 1/4W, 1%, 5.11 kΩ	110-5.11k-1
R84	MF, 1/4W, 1%, 1M	110-1M-1
R85	MF, 1/4W, 1%, 100 kΩ	110-100k-1
R86	MF, 1/4W, 1%, 5.11Ω	110-5.11-1
R87	MF, 1/4W, 1%, 5.11 kΩ	110-5.11k-1

R88	Variable, 1-Turn, 20Ω	156-20
R89	MF, 1/4W, 1%, 15 kΩ	110-15k-1
R90	Not Used	
R91	Not Used	
R92	MF, 1/4W, 1%, 511Ω	110-511-1
R93	MF, 1/4W, 1%, 511Ω	110-511-1
R94	Variable, 15-Turn, 1 kΩ	157-1k
R95	MF, 1/4W, 1%, 5.11 kΩ	110-5.11k-1
R96	MF, 1/4W, 1%, 10 kΩ	110-10k-1
R97	MF, 1/4W, 1%, 750 kΩ	110-750k-1
R98	MF, 1/4W, 1%, 14.7 kΩ	110-14.7k-1

INTEGRATED CIRCUITS

REF. DES.	DESCRIPTION	WILTRON PART NO.
U1	Quad EX-OR Gate, 74LS86	54-125
U2	Quad Op Amp, TL074	54-132
U3	Quad Analog Switch, LF13201	54-20
U4	Op-Amp, OP05	54-87
U5	2k x 8 EPROM	Not Field-Replaceable
U7	Dual Analog Switch, DG200	50-DG200BA
U8	Dual Op-Amp, TL072	54-53
U9	Quad Volt Comparator, MC3302P	54-MC3302P
U10	Input NAND Gate, 74LS10	54-42

MISCELLANEOUS

REF. DES.	DESCRIPTION	WILTRON PART NO.
---	Ejector, P.C. Board	553-96
TP1 thru TP5	Pin, Test Point	706-44
K1	Relay, 2 Form C	690-28
---	Socket, I.C., 24-Pin	553-67

MANUAL CHANGES (Continued)

- b. Opposite the 4th bullet (black dot), change the text to read:

"An adjustable +15-volt bias for the RF Amplifier that follows Osc. 1 in the 6617A-40, 6621A-40, 6637A-40, and 6647A-40."

- c. In the last paragraph on page 7-116, change the 1st sentence to read:

"The input to the +15V Bias Supply...."

4. Pages 7-117 thru 7-124

Remove these pages, and replace them with changed pages 7-117 thru 7-124 containing changed Figures 7-62 and 7-63, following.

5. Pages 7-125 and 7-126, Figure 7-64

Delete these pages, and remove them from the manual.

6. Pages 7-134 thru 7-138, paragraph 7-12.5 and Figure 7-70

Delete these pages, and remove them from the manual.

7. Page 7-220, Figure 7-112

- a. Replace this figure with the changed Figure 7-112, following.
- b. Add Figure 7-112A, following.

PCOs 2697 and 2698 11/82
2703 and 2704 2/83

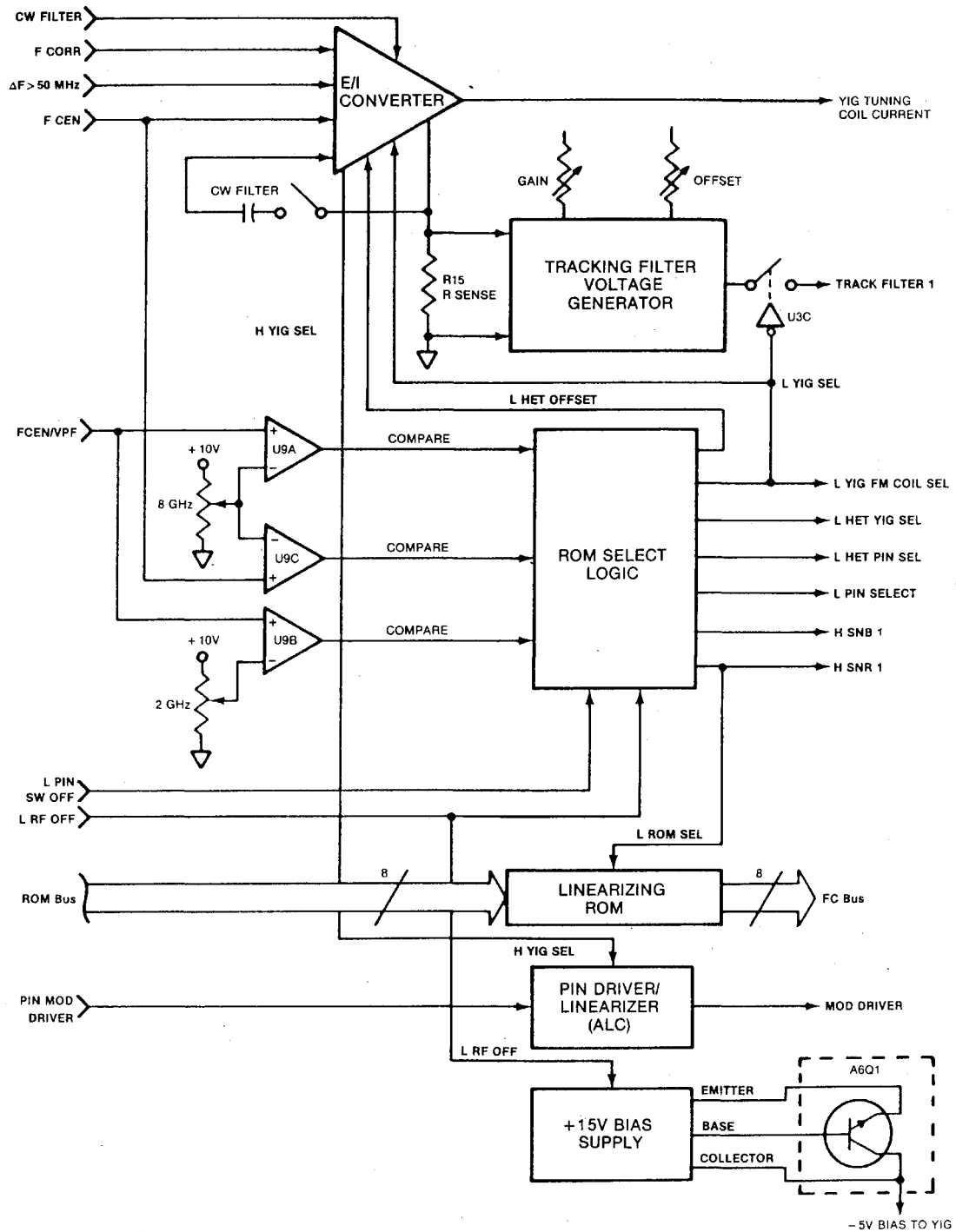

Figure 7-60. A6 Het/YIG Driver PCB
 (Assy. 660-D-8007 (Block
 Diagram))

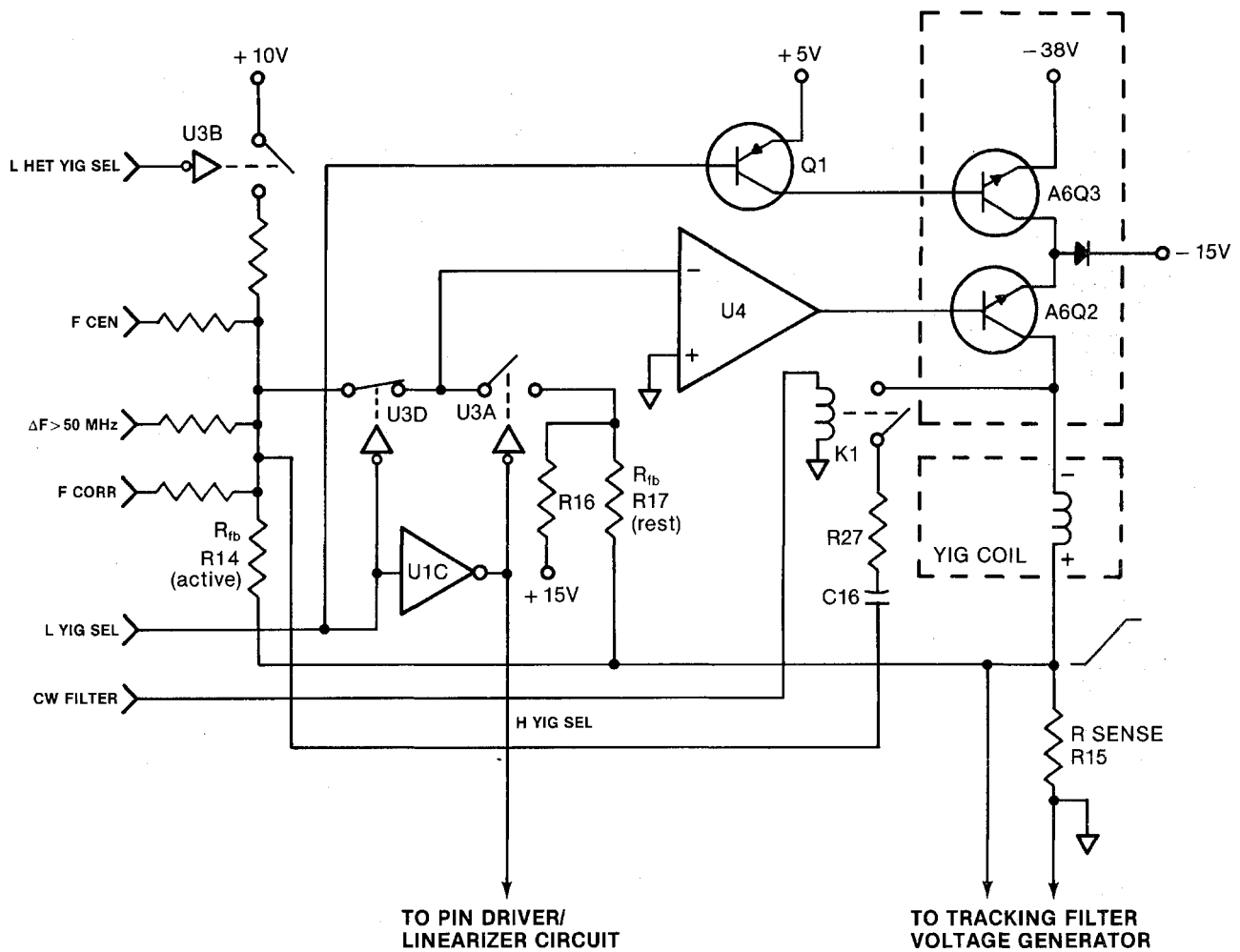
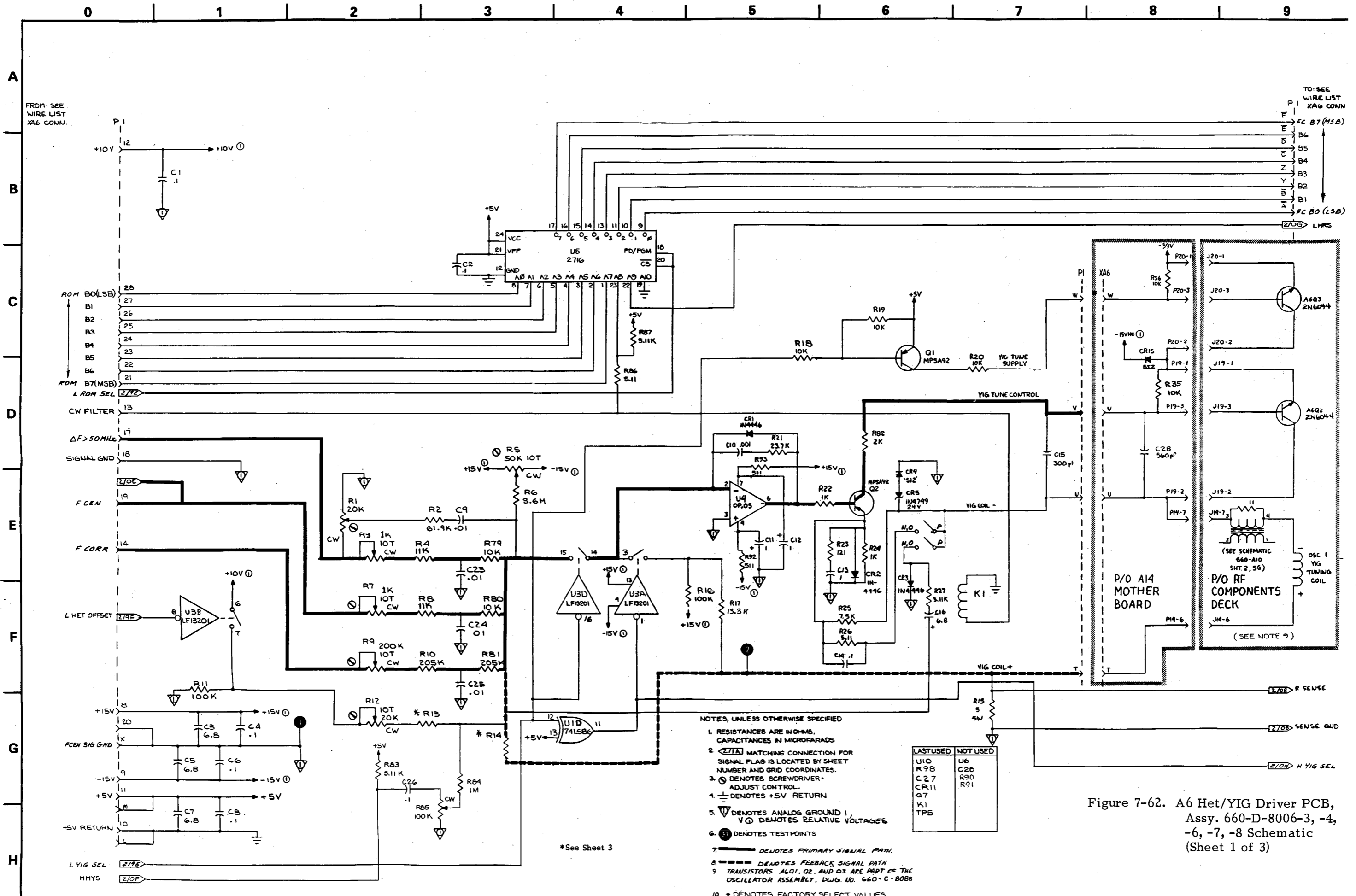

Figure 7-61. A6 Het/YIG Driver PCB
E/I Converter Circuit
Simplified Schematic



- NOTES, UNLESS OTHERWISE SPECIFIED
1. RESISTANCES ARE IN OHMS, CAPACITANCES IN MICROFARADS
 2. MATCHING CONNECTION FOR SIGNAL FLAG IS LOCATED BY SHEET NUMBER AND GRID COORDINATES.
 3. DENOTES SCREWDRIVER-ADJUST CONTROL.
 4. DENOTES +5V RETURN
 5. DENOTES ANALOG GROUND | DENOTES RELATIVE VOLTAGES
 6. DENOTES TESTPOINTS
 7. DENOTES PRIMARY SIGNAL PATH.
 8. DENOTES FEEDBACK SIGNAL PATH
 9. TRANSISTORS A6Q1, Q2, AND Q3 ARE PART OF THE OSCILLATOR ASSEMBLY, DWG. NO. 660-C-8088
 10. * DENOTES FACTORY SELECT VALUES

LAST USED	NOT USED
U10	U16
R98	C20
C27	R90
CR11	R91
Q7	
K1	
TP5	

Figure 7-62. A6 Het/YIG Driver PCB, Assy. 660-D-8006-3, -4, -6, -7, -8 Schematic (Sheet 1 of 3)

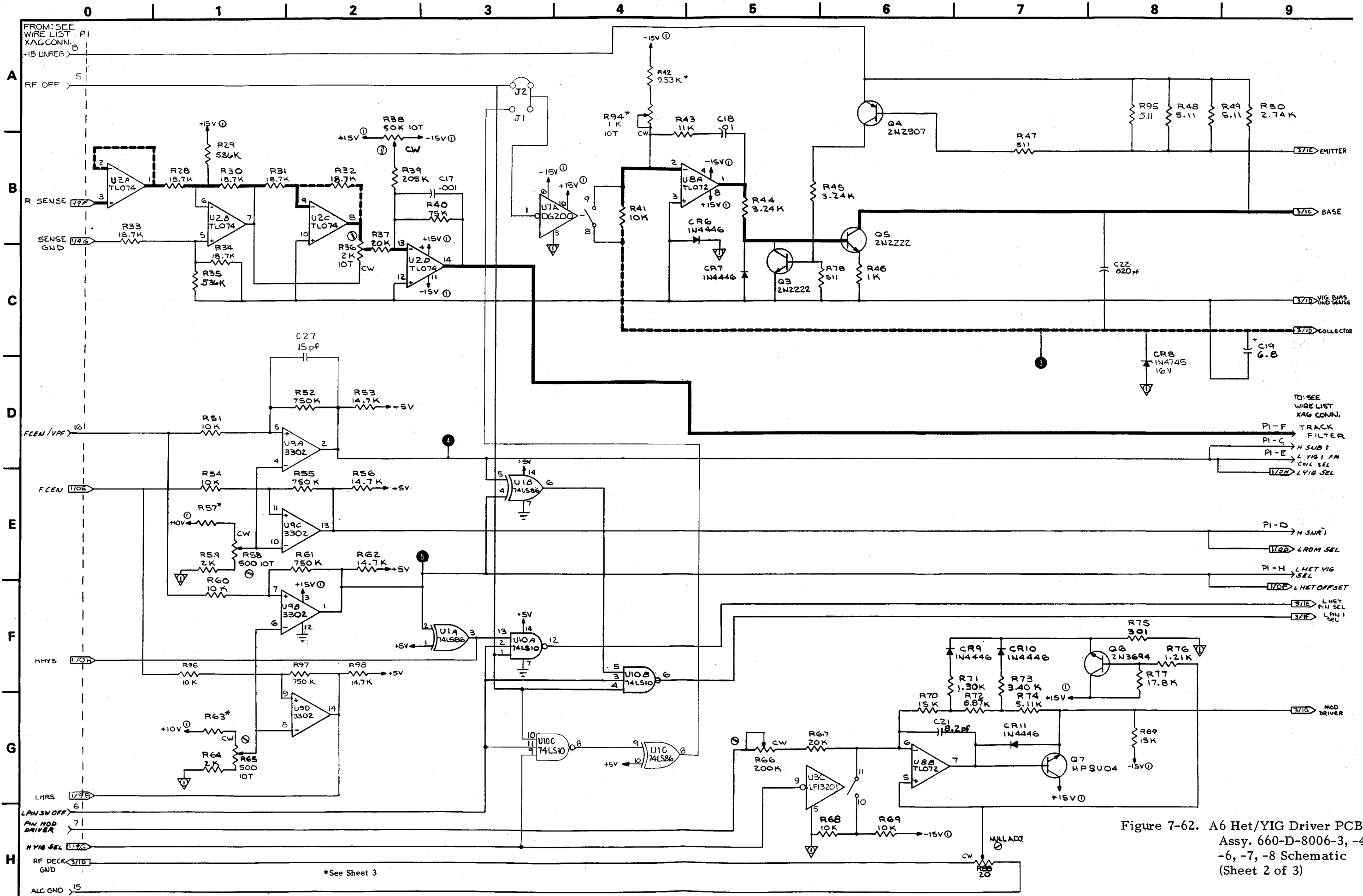
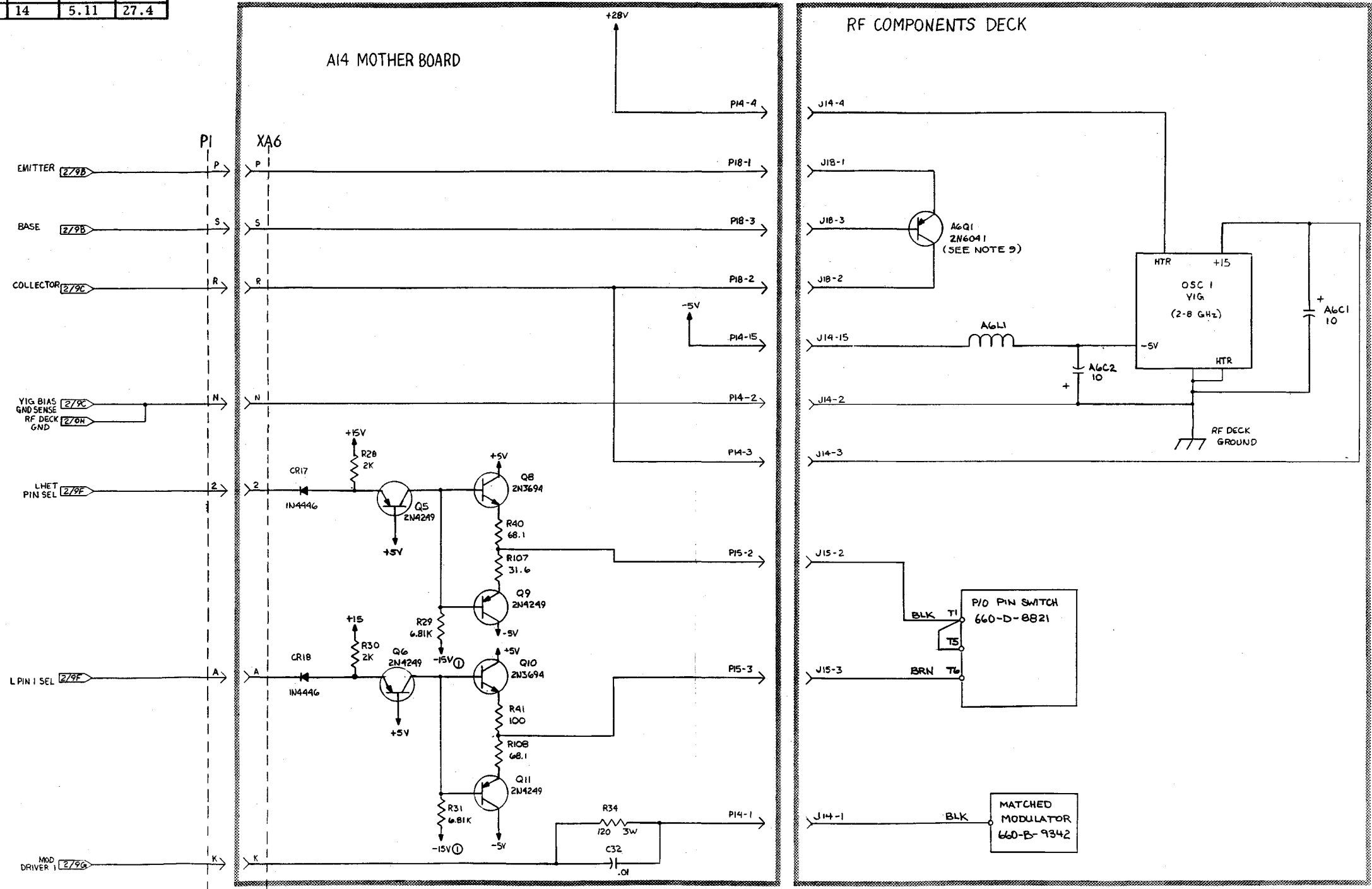

Figure 7-62. A6 Het/YIG Driver PCB, Assy. 660-D-8006-3, -4, -6, -7, -8 Schematic (Sheet 2 of 3)

MODELS	RESISTORS (kΩ)			
	R13	R14	R57	R63
6617A	56.3	4.22	5.11	6.49
6621A	-----	6.65	0.976	-----
6637A/6647A	75	9.76	2.74	18.2
6638A/6648A	75	10.2	3.16	20
6653A/6659A	110	14	5.11	27.4



SEE SHEET 1 FOR NOTES

Figure 7-62. A6 Het/YIG Driver PCB, Assy. 660-D-8006-3, -4, -6, -7, -8 Schematic (Sheet 3 of 3)

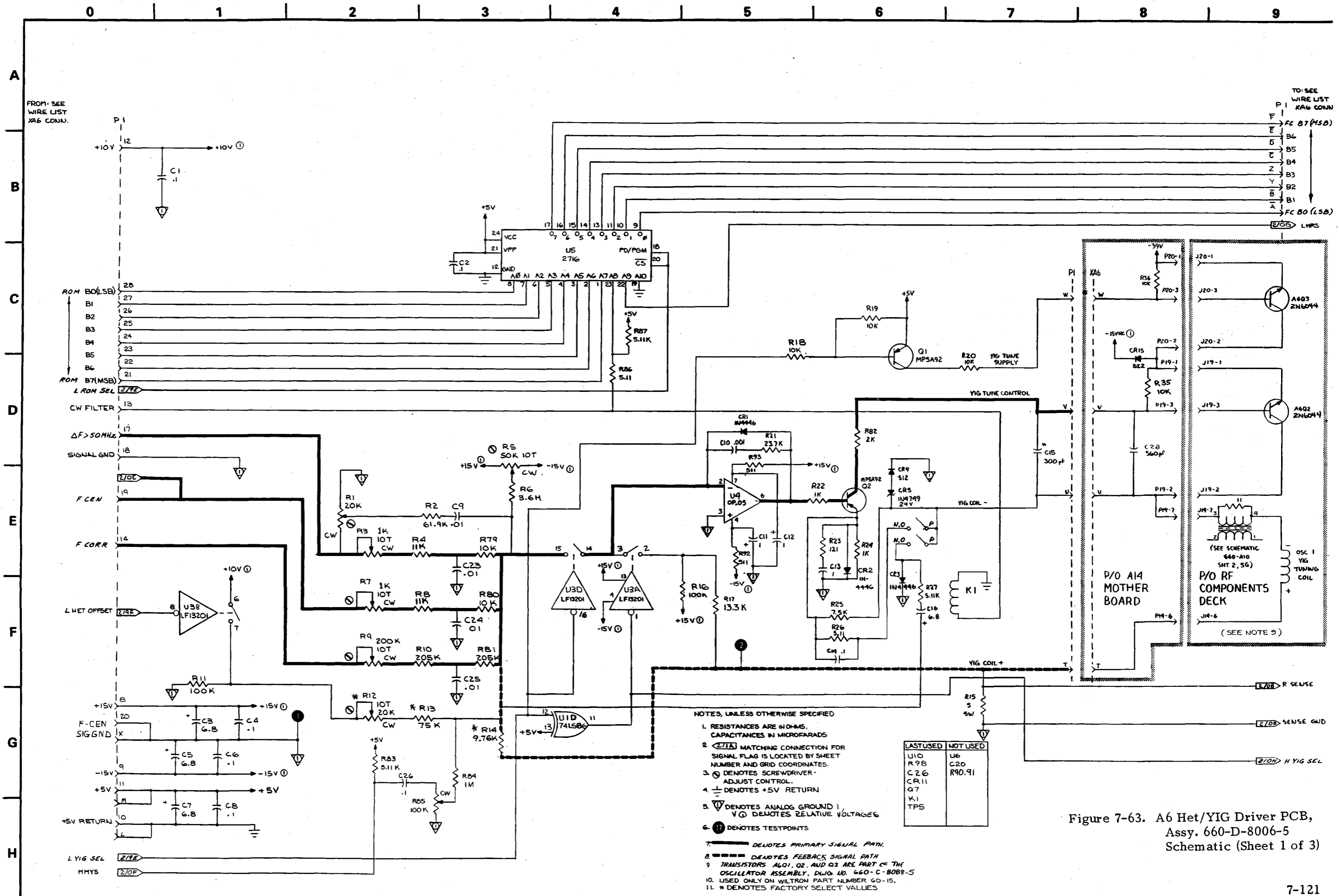

- NOTES, UNLESS OTHERWISE SPECIFIED
1. RESISTANCES ARE IN OHMS, CAPACITANCES IN MICROFARADS
 2. **Z/A** MATCHING CONNECTION FOR SIGNAL FLAG IS LOCATED BY SHEET NUMBER AND GRID COORDINATES.
 3. **⊕** DENOTES SCREWDRIVER-ADJUST CONTROL.
 4. **⊖** DENOTES +5V RETURN
 5. **∇** DENOTES ANALOG GROUND 1, **∇** DENOTES RELATIVE VOLTAGES
 6. **Ⓢ** DENOTES TESTPOINTS
 7. **—** DENOTES PRIMARY SIGNAL PATH.
 8. **---** DENOTES FEEDBACK SIGNAL PATH
 9. TRANSISTORS A601, Q2, AND Q3 ARE PART OF THE OSCILLATOR ASSEMBLY, DWG. NO. 660-C-8088-5
 10. USED ONLY ON WILTRON PART NUMBER 60-15.
 11. * DENOTES FACTORY SELECT VALUES

LAST USED	NOT USED
U10	U6
R98	C20
C26	R90,91
CR11	
Q7	
K1	
TP5	

Figure 7-63. A6 Het/YIG Driver PCB, Assy. 660-D-8006-5 Schematic (Sheet 1 of 3)

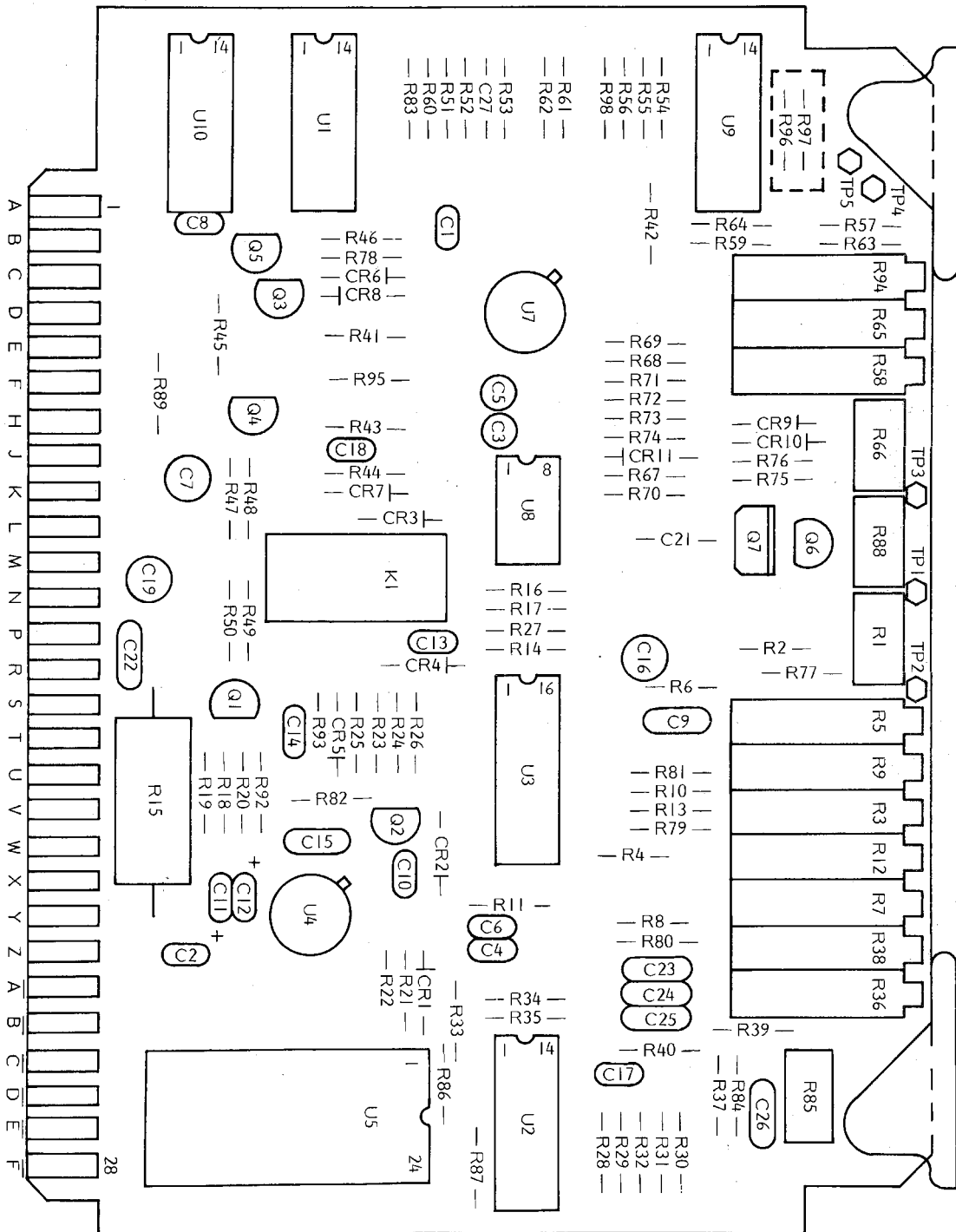

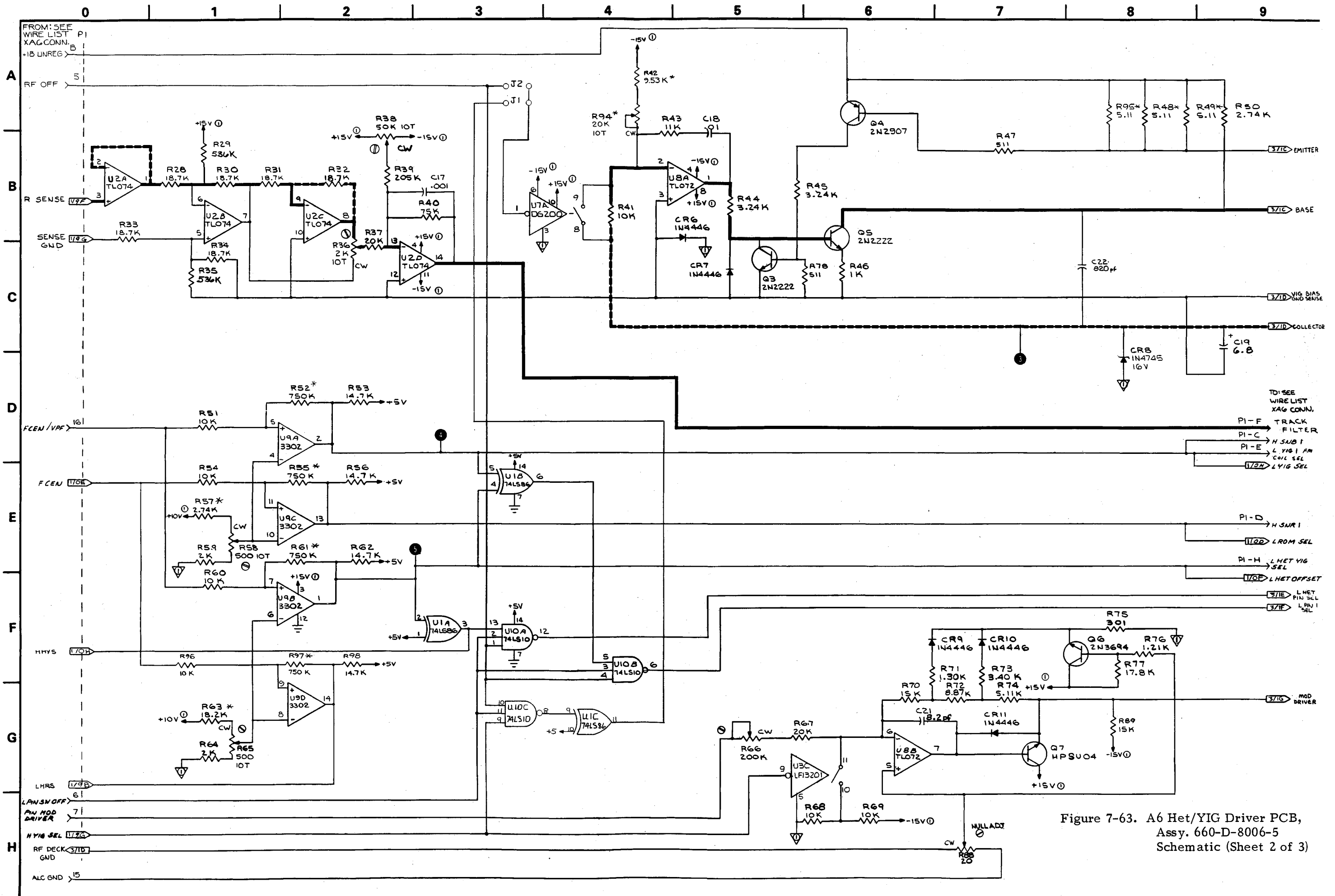
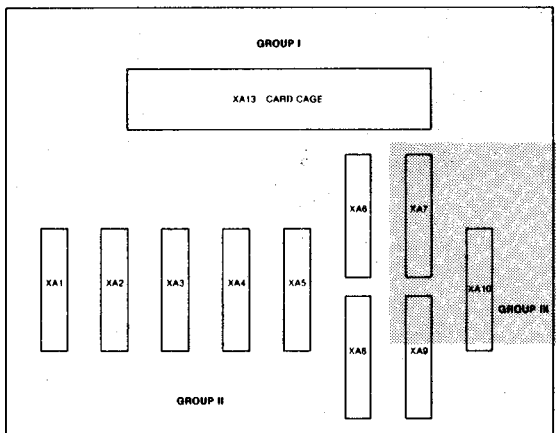
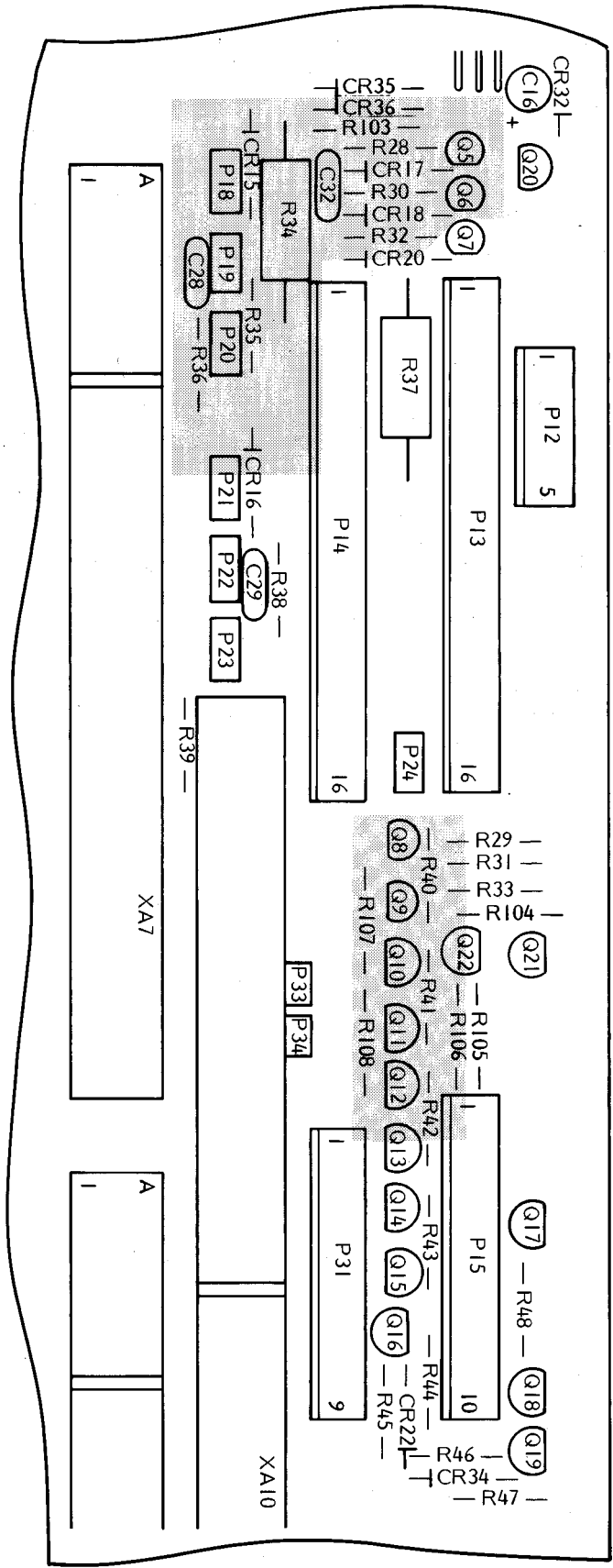
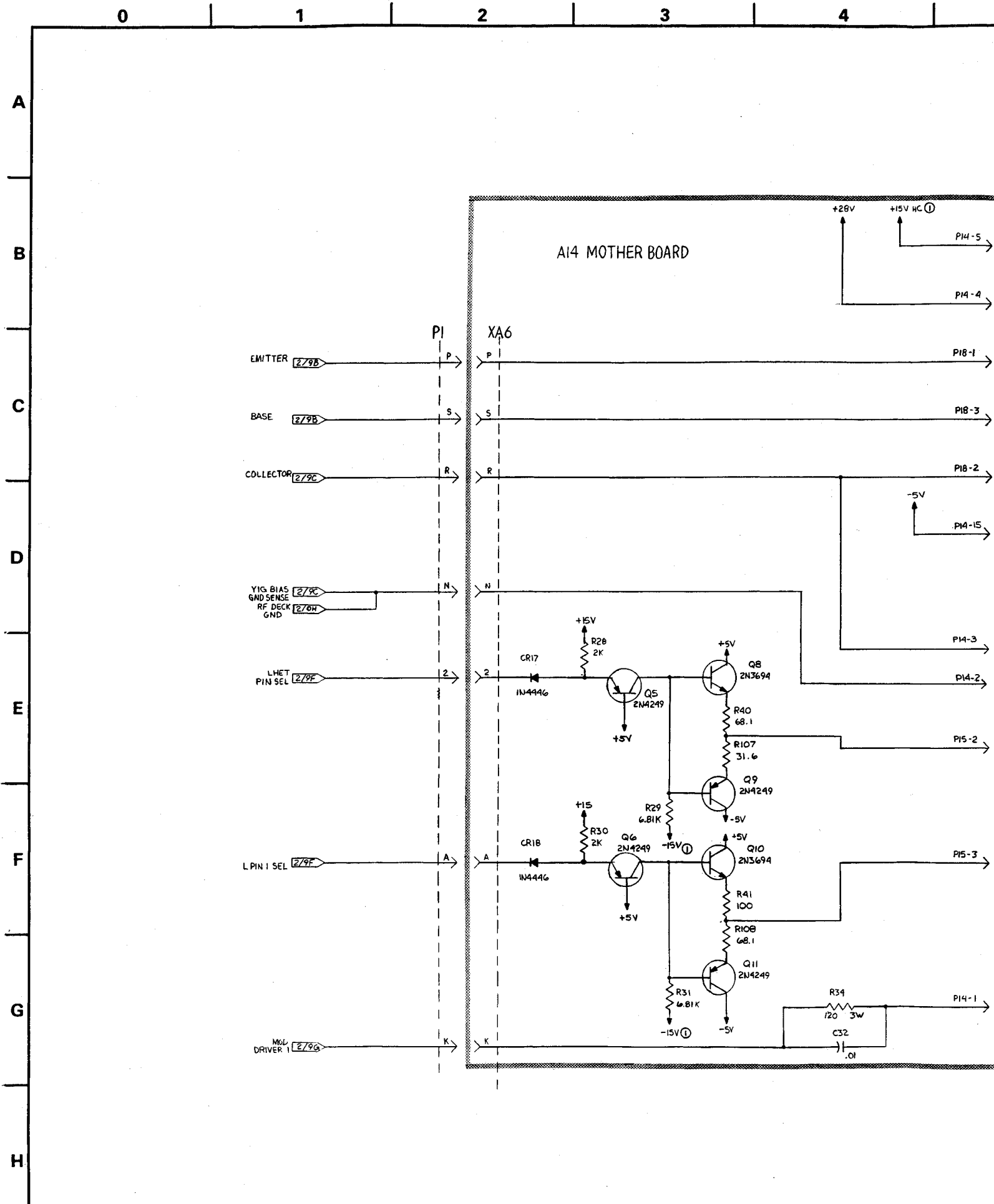
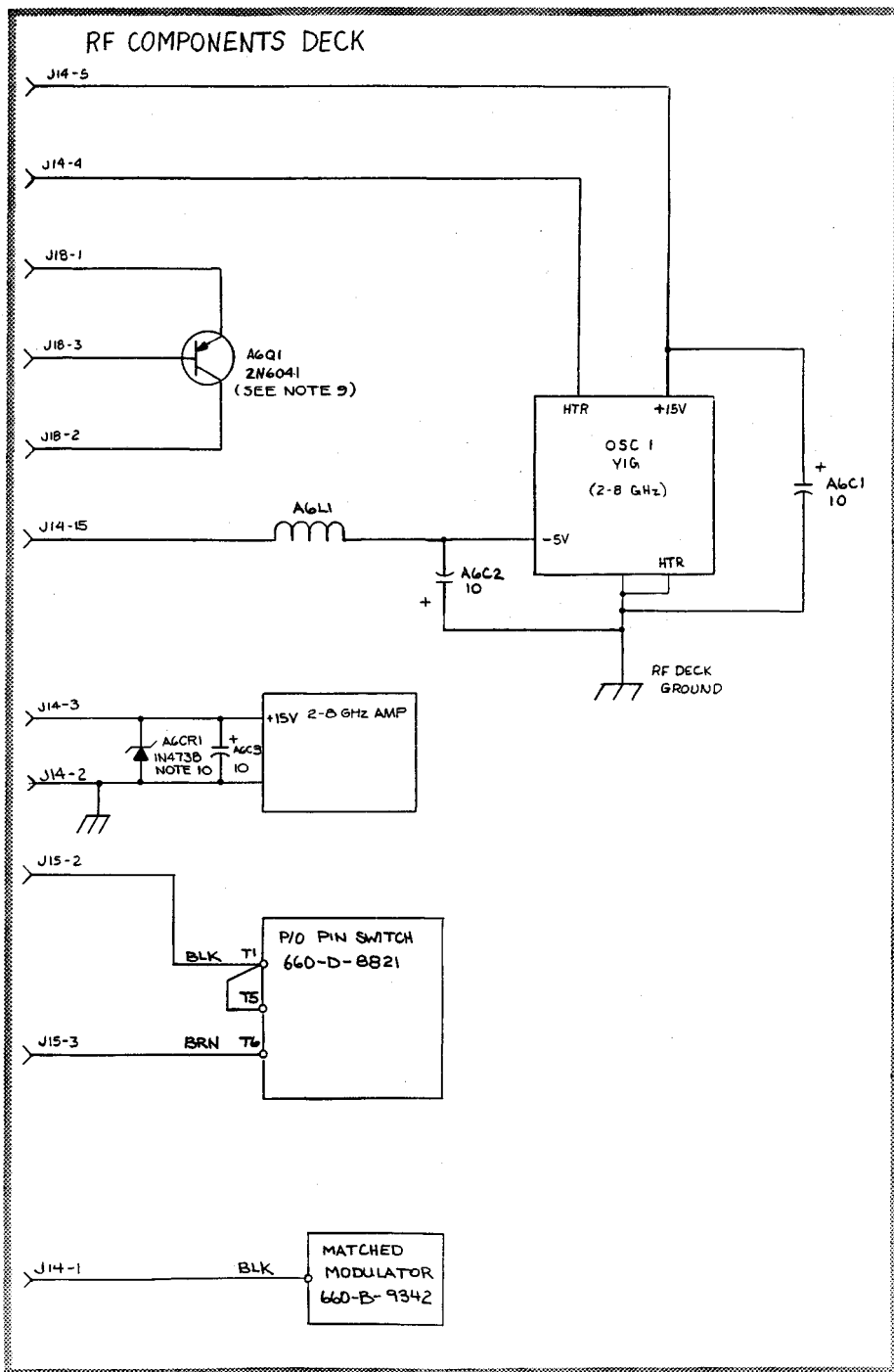

Figure 7-63. A6 Het/YIG Driver PCB, Assy. 660-D-8006-5 Schematic (Sheet 2 of 3)



Osc 1 YIG, PIN Driver, and PIN/Modulator Parts Locator Diagram





SEE SHEET 1 FOR NOTES

Figure 7-63. A6 Het/YIG Driver PCB, Assy. 660-D-8006-5 Schematic (Sheet 3 of 3)

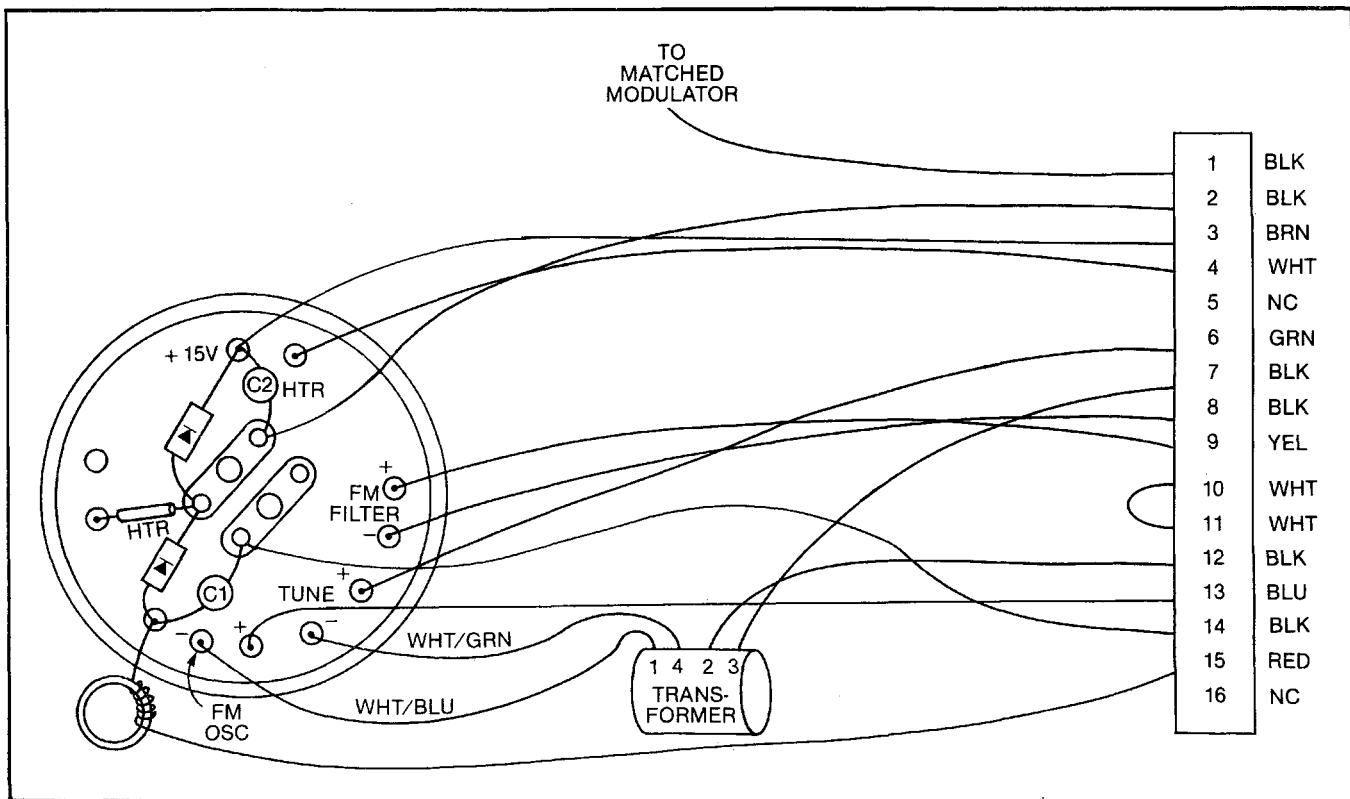

Figure 7-112. 6617A/6637A/6638A/6647A/6648A/6653A/6659A A6 Oscillator Wiring Diagram (Changed March 15, 1983)

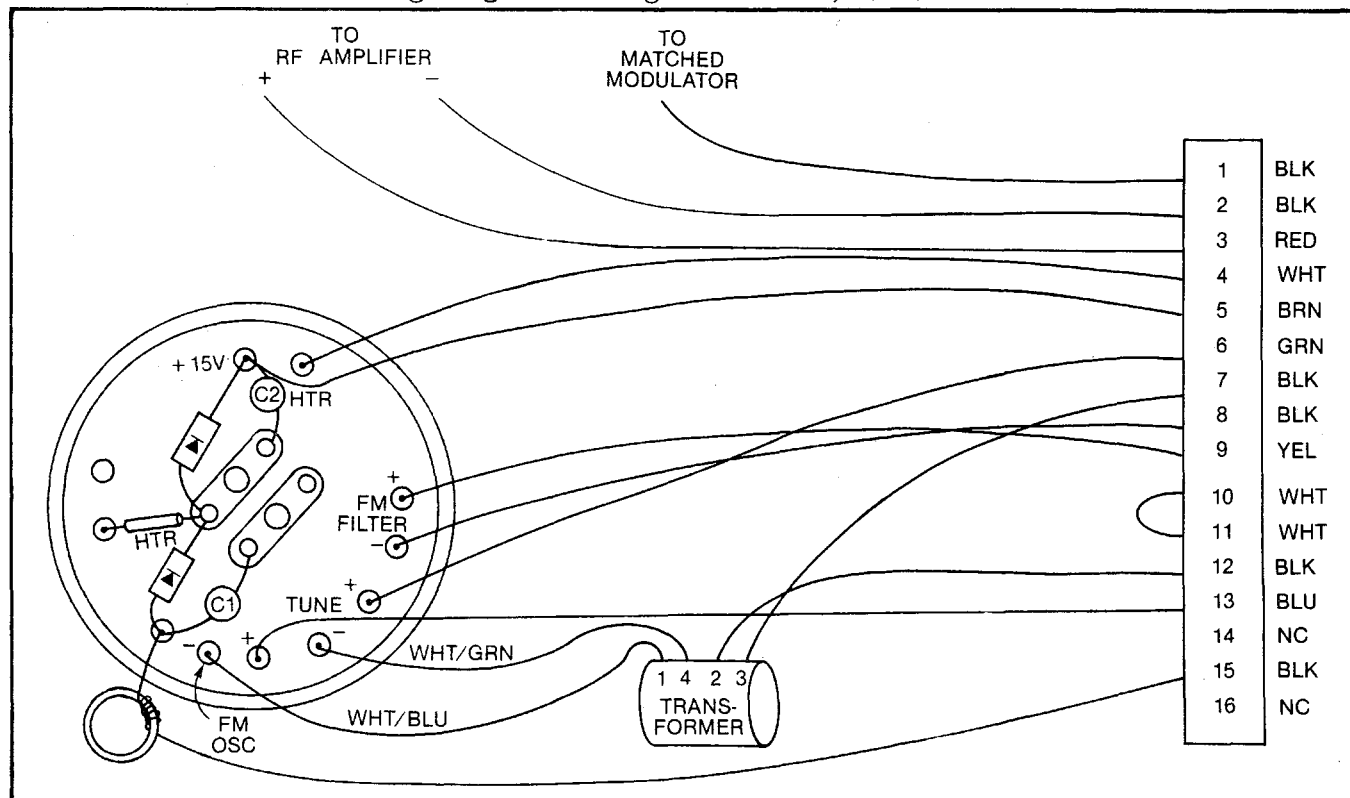

Figure 7-112A. 6617A-40/6621A-40/6637A-40/6647A-40 A6 Oscillator Wiring Diagram

MANUAL CHANGES (Continued)

CHANGE #15 **MODELS AFFECTED: All**
BASIC FRAME SN: 313001 & up

1. Page 6-19, Table 6-3, "RESISTORS" Grouping

Change to read:

"REF DES.	DESCRIPTION	WILTRON PART NO.
R17	MF, 1/4W, 1%, 261 kΩ	110-261k-1
R18	MF, 1/4W, 1%, 261 kΩ	110-261k-1
R24	MF, 1/4W, 1%, 261 kΩ	110-261k-1
R25	MF, 1/4W, 1%, 261 kΩ	110-261k-1
R31	MF, 1/4W, 1%, 261 kΩ	110-261k-1
R32	MF, 1/4W, 1%, 261 kΩ	110-261k-1
R58	MF, 1/4W, 1%, 30.1 kΩ	110-30.1k-1
R60	MF, 1/4W, 1%, 2.49 kΩ	110-2.49k-1"

2. Page 7-74, Figure 7-38, Sheet 2

- a. At coordinates 6A, change the values of R17 and R18 to "261 K."
- b. At coordinates 6B, change the values of R24 and R25 to "261 K."
- c. At coordinates 6D, change the values of R31 and R32 to "261 K."

3. Page 7-75, Figure 7-38, Sheet 3

At coordinates 6E, change the values of R58 to "30.1 K" and R60 to "2.49 K."

PCO 2721 2/83

CHANGE #16 **MODELS AFFECTED: All**
BASIC FRAME SN: 311001 & up

1. Page 6-48, Table 6-22, "MISCELLANEOUS" Grouping

Add:

REF DES.	DESCRIPTION	WILTRON PART NO.
---	Power Down Circuit PCB	660-A-13642

MANUAL CHANGES (Continued)

2. Page 7-18, paragraph 7-6.1c

Add the following paragraph to the end of the RAM circuit description:

"When the ac power is turned off, the Power Down Circuit resets the microprocessor via the RESIN input, to prevent possible RAM memory loss."

3. Page 7-19, Figure 7-11

Change as shown below

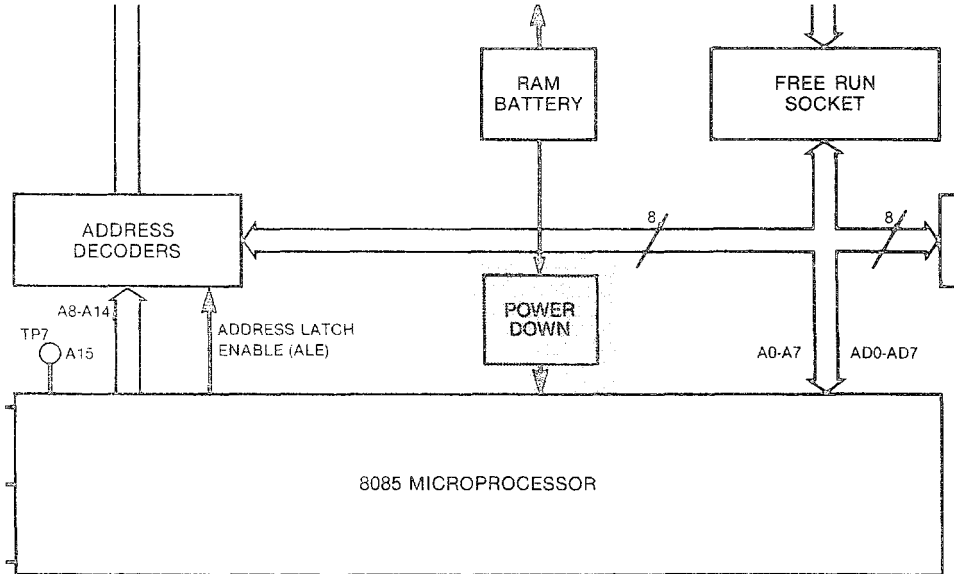

4. Page 7-21, Figure 7-14

Change as shown below.

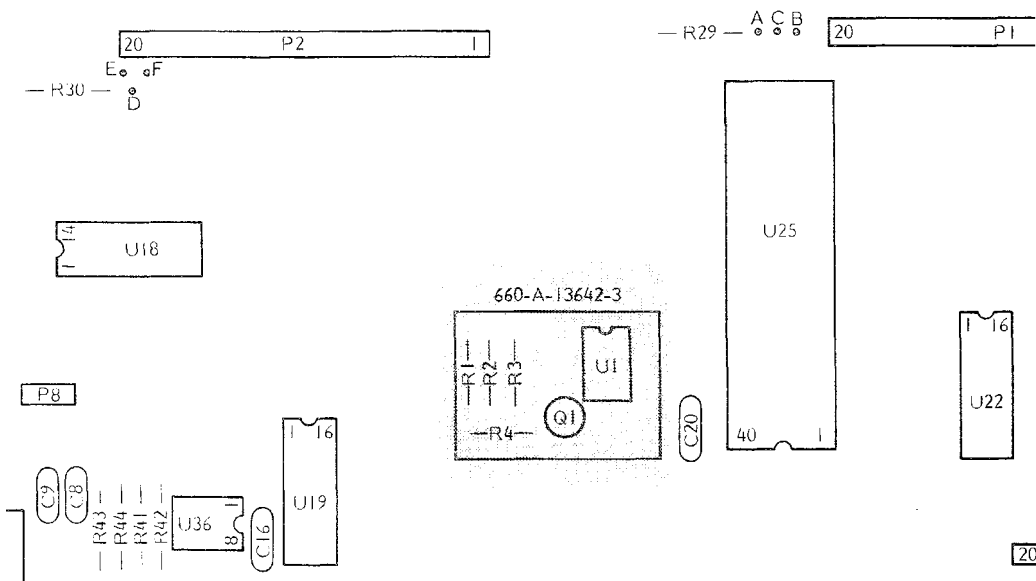

MANUAL CHANGES (Continued)

5. Page 7-22, Figure 7-15

Add the Power Down circuit (660-A-13642 PCB) as shown below.

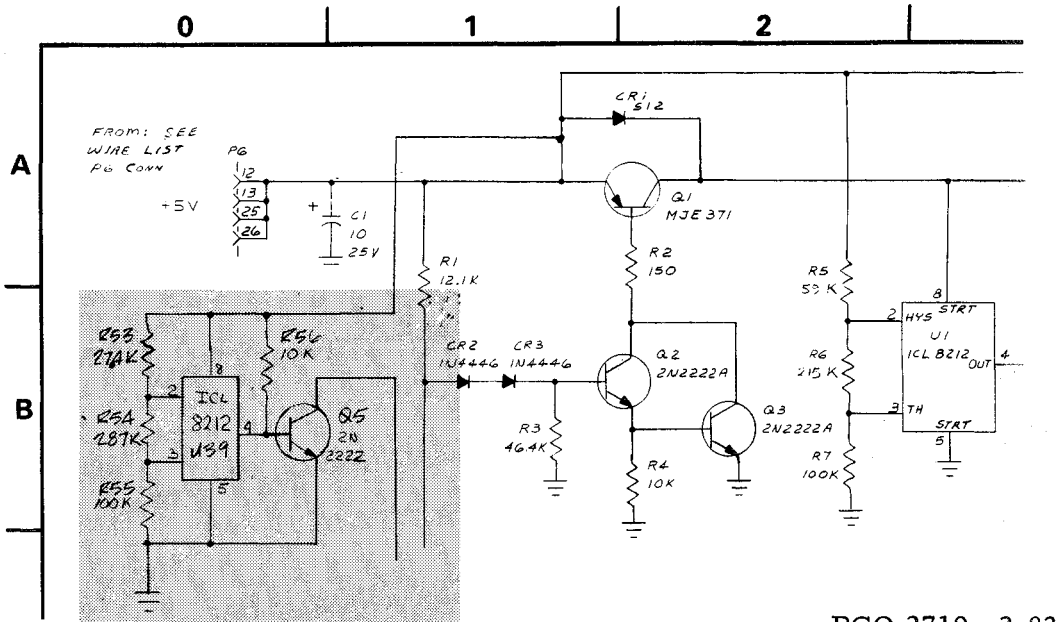

PCO 2719 2-83

CHANGE #17

MODELS AFFECTED: 6609A
BASIC FRAME SN: 303004 & up

1. Page 6-37, Table 6-15

- a. Under "CAPACITORS," change the value of C5 to .0047 µF and the part number to 230-36.
- b. Under "RESISTORS," change the value of R18 to 2 kΩ and the part number to 110-2k-1.

2. Page 7-130 (Changed 1 Feb 83), Figure 7-67

- a. At coordinates 4B, change the value of C5 to .0047 µF and the value of R18 to 2 kΩ.

TCO G930 3-83

TABLE OF CONTENTS

<u>Section</u>		<u>Page</u>
I	GENERAL INFORMATION	
1-1	Scope of the Manual	1-1
1-2	Introduction	1-1
1-3	Description	1-1
1-4	Identification Number	1-1
1-5	Options	1-1
1-6	Specifications	1-2
1-7	Characteristics	1-2
II	INSTALLATION	
2-1	Introduction	2-1
2-2	Initial Inspection	2-1
2-3	Preparation for Use	2-1
2-4	GPIB Setup and Interconnection	2-2
2-4.1	Interface Connector	2-2
2-4.2	Cable Length Restrictions	2-2
2-4.3	GPIB Interconnection	2-3
2-4.4	GPIB Address	2-3
2-4.5	Data Delimiting (CR-CR/LF Switch)	2-3
2-4.6	Option 3 (GPIB) Installation	2-4
2-5	Preparation for Storage and/or Shipment	2-4
2-5.1	Preparation for Storage	2-5
2-5.2	Preparation for Shipment	2-5
III	OPERATION	
3-1	Introduction	3-1
3-2	Front Panel Controls	3-1
3-2.1	DATA ENTRY Pushbuttons	3-1
3-2.2	FREQUENCY RANGE Pushbuttons	3-6
3-2.3	TRIGGER Pushbuttons	3-8
3-2.4	MARKERS Pushbuttons	3-9
3-2.5	LEVELING Controls	3-10
3-2.6	RF OUTPUT Controls, Indicators, and Connector	3-10
3-2.7	POWER, SELF TEST, and RESET Controls	3-11
3-2.8	BUS ADRS/RETURN TO LOCAL Control and GPIB Indicators	3-11

TABLE OF CONTENTS (Continued)

<u>Section</u>	<u>Page</u>
(III) 3-3 Rear Panel Controls and Connectors	3-13
3-4 Self-Test Features	3-13
3-5 Operational Checkout Procedures	3-21
3-5.1 Operational Checkout, Sweep Generator Confidence Test	3-21
3-5.2 Operational Checkout Procedure, FREQUENCY VERNIER Pushbuttons and Phase-Lock Operation	3-22
3-5.3 Operational Checkout Procedure, External Leveling Function (All Models Except 6642A)	3-24
3-5.4 Operational Checkout Procedure, External Leveling Function (6642A)	3-27
3-6 Description of the IEEE-488 (IEC-625) Interface Bus	3-29
3-6.1 Data Bus Description	3-30
3-6.2 Management Bus Description	3-30
3-6.3 Data Byte Transfer Control (Handshake) Bus Description	3-30
3-7 GPIB Operation (Option 3)	3-31
3-7.1 GPIB Commands: Front Panel Controls	3-32
3-7.2 GPIB Commands: Step Sweep	3-36
3-7.3 GPIB Commands, Group Execute Trigger Modes	3-37
3-7.4 GPIB Commands: Service Request Modes	3-38
3-7.5 GPIB Commands: Output	3-41
3-7.6 GPIB Commands: Miscellaneous	3-42
3-7.7 Bus Messages	3-45
3-7.8 Program Errors	3-48
3-7.9 Reset Programming and Default Conditions	3-50
3-7.10 Quick Reference Data	3-51
3-7.11 Index of Sweep Generator GPIB Command Codes	3-51
 IV PERFORMANCE VERIFICATION	
4-1 Introduction	4-1
4-2 Recommended Test Equipment	4-1
4-3 Frequency Accuracy Tests	4-1
4-4 Sweep Time Test	4-5
4-5 Output Power Tests	4-6
4-6 Residual AM Test	4-8
4-7 Residual FM Test	4-10
4-8 External FM and Phase-Lock Test	4-11
4-9 RF Output Signal Tests, All Models Except 6642A, 6653A, and 6659A	4-12

TABLE OF CONTENTS (Continued)

<u>Section</u>		<u>Page</u>
(IV)	4-10 RF Output Signal Tests, Model 6642A	4-15
	4-11 RF Output Signal Tests, Models 6653A and 6659A	4-18
V	CALIBRATION AND ADJUSTMENTS	
	5-1 Introduction	5-1
	5-2 Recommended Test Equipment	5-1
	5-3 Adjustments Following PCB or Component Repair or Replacement	5-1
	5-4 Power Supply Adjustments	5-1
	5-5 A2 Ramp Generator Adjustments	5-5
	5-6 A5 Frequency Instruction Adjustments	5-9
	5-7 A3 Marker Generator Adjustments	5-12
	5-8 A6-A9 YIG (Het/YIG) Driver PCB Adjustments	5-17
	5-8.1 A6-A9 Oscillator-Bandswitching Voltage Adjustments	5-17
	5-8.2 YIG Bias Check	5-21
	5-9 Frequency Calibration	5-23
	5-10 2-8 GHz Band (Osc 1) Tracking Filter Adjustments (Models 6617A, 6647A, 6648A, and 6659A)	5-31
	5-11 Sweep Rate Compensation Adjustment	5-34
	5-12 ALC Loop Calibration	5-34
	5-12.1 ALC Loop Adjustments (All Models Except 6642A, 26.5 to 40 GHz Band)	5-34
	5-12.2 ALC Loop Adjustments (Model 6642A, 26.5-40 GHz Band)	5-41
VI	PARTS LISTS	
	6-1 Introduction	6-1
	6-2 Parts-Ordering Information	6-1
	6-3 Abbreviations	6-1
	6-4 Organization of Parts Listings	6-1
VII	SERVICE	
	7-1 Introduction	7-1

TABLE OF CONTENTS (Continued)

<u>Section</u>		<u>Page</u>
(VII)	7-2 General Information	7-1
	7-2.1 Printed Circuit Board (PCB) Exchange Program	7-1
	7-2.2 Recommended Test Equipment for Troubleshooting	7-1
	7-3 6600A Series Programmable Sweep Generator, Removal and Reinstallation Instructions	7-1
	7-3.1 Front Panel Assembly, Removal and Reinstallation Instructions	7-1
	7-3.2 Front Panel, Disassembly and Reassembly Instructions	7-3
	7-3.3 INCREASE/DECREASE Lever, Switch-Assembly Replacement	7-6
	7-3.4 Rear Panel Assembly, Removal and Reinstallation Instructions	7-6
	7-3.5 A13 Switching Power Supply PCB, Removal and Reinstallation	7-7
	7-4 6600A Series Programmable Sweep Generator, Overall Circuit Description	7-8
	7-5 6600A Series Programmable Sweep Generator, Overall Troubleshooting	7-17
	7-6 A12 Microprocessor PCB	7-17
	7-6.1 A12 Microprocessor PCB, Circuit Description	7-17
	7-6.2 A12 Microprocessor PCB, Troubleshooting Information and Data	7-27
	7-7 A11 Front Panel PCB	7-35
	7-7.1 A11 Front Panel PCB, Circuit Description	7-35
	7-7.2 A11 Front Panel PCB, Troubleshooting Information	7-35
	7-8 A1 GPIB Interface PCB	7-41
	7-8.1 A1 GPIB Interface PCB, Circuit Description	7-41
	7-8.2 A1 GPIB Interface PCB, Troubleshooting Information and Data	7-49
	7-9 A2 Ramp Generator PCB	7-55
	7-9.1 A2 Ramp Generator PCB, Circuit Description	7-55
	7-9.2 A2 Ramp Generator PCB, Troubleshooting Information and Data	7-64
	7-10 A3 Marker Generator PCB	7-67
	7-10.1 A3 Marker Generator PCB, Circuit Description	7-67
	7-10.2 A3 Marker Generator PCB, Troubleshooting Information and Data	7-77
	7-11 A4 Automatic Level Control (ALC) PCB	7-83
	7-11.1 A4 Automatic Level Control (ALC) PCB, Circuit Description	7-83
	7-11.2 Sweep Generator Automatic Leveling Control (ALC) Loop, Troubleshooting Information and Data	7-89

TABLE OF CONTENTS (Continued)

<u>Section</u>	<u>Page</u>
(VII)	
7-12 A5 Frequency Instruction and A6-A9 YIG Driver PCBs	7-106
7-12.1 A5 Frequency Instruction PCB, Circuit Description	7-106
7-12.2 A6-A9 YIG Driver PCBs, Overall Description	7-113
7-12.3 Assy 660-D-8007-3, -5, -7, and -99 -91; -12868-3 and -99-91 Het/YIG Driver PCBs, Circuit Description	7-115
7-12.4 Assy 660-D-8007-4 Het/YIG Driver PCB, Circuit Description	7-128
7-12.5 Assy 660-D-8007-6 Het/YIG Driver PCB, Circuit Description	7-134
7-12.6 Assy 660-D-8190 and 8191 YIG Driver PCB, Circuit Description	7-140
7-12.7 Assy 660-D-8008 and -8009 YIG Driver PCBs (All Dash Numbers), Circuit Description	7-148
7-12.8 A5 Frequency Instruction and A6-A9 YIG Driver PCBs, Troubleshooting Information and Data	7-171
7-13 A10 FM/Attenuator PCB	7-175
7-13.1 A10 FM/Attenuator PCB, Circuit Description	7-175
7-13.2 A10 FM/Attenuator PCB, Troubleshooting Information and Data	7-180
7-14 RF Deck, Circuit Description	7-183
7-15 A13/A14 Switching Power Supply and A14 Motherboard PCBs	7-190
7-15.1 A13/A14 Switching Power Supply, Circuit Description	7-190
7-15.2 A4 Motherboard PCB, Wire Lists and Service Data	7-199
7-15.3 A13/A14 Switching Power Supply, Troubleshooting Information and Data	7-230
7-16 A18 GPIB Connector PCB, Circuit Description	7-230
 <u>APPENDIX</u>	
1 QUICK REFERENCE DATA	A1-1
2 STEP SWEEP STEP-TO-FREQUENCY CONVERSION FORMULA	A2-1
3 μ P OUTPUT PORTS (μ P-TO-ANALOG INTERFACE)	A3-1

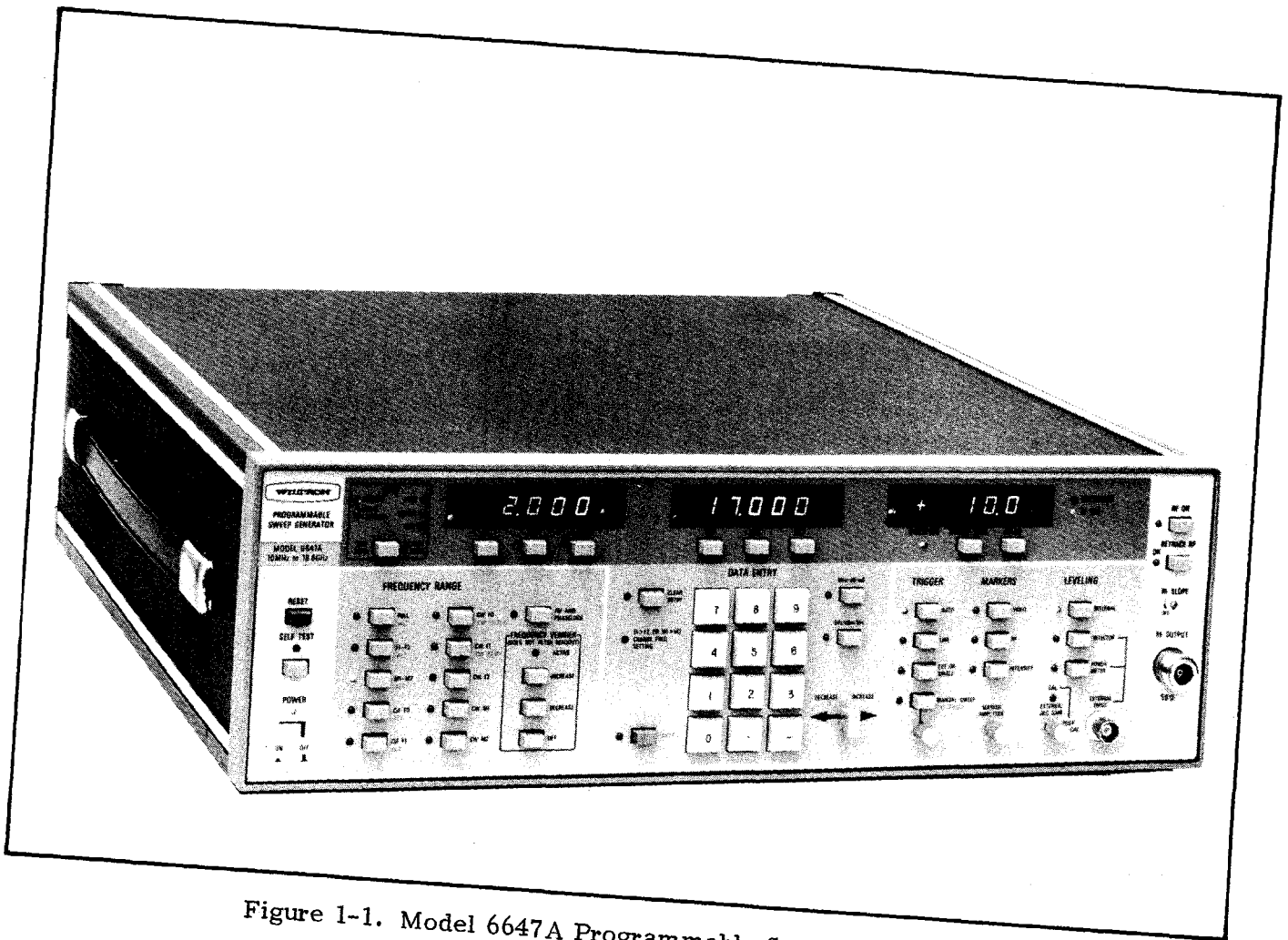

Figure 1-1. Model 6647A Programmable Sweep Generator

SECTION I

GENERAL INFORMATION

1-1 SCOPE OF THE MANUAL.

This manual is the operation and maintenance (O&M) manual for the multiband models (paragraph 1-3) of the 6600A Series Programmable Sweep Generator. The manual provides general information, installation, operation, performance verification, calibration, replaceable parts, and maintenance/service information and instructions. Refer to the Table of Contents for the manual organization.

1-2 INTRODUCTION

Section I provides a description, specifications, characteristics, and option information.

1-3 DESCRIPTION

The 6600A Series (Figure 1-1) is a family of microprocessor-based, pushbutton-controlled, GPIB-capable, broadband signal sources that generate swept and CW frequencies from 10 MHz to 40 GHz. This ever-expanding family of sweepers presently consists of 29 models. These 29 models are divided into single-band and multiband sweep generators, depending upon the number of internal bands used for frequency-range coverage. Single-band models use one YIG oscillator to span their range, whereas multiband models use two or more YIGs, or a combination consisting of a YIG (or YIGs) and a frequency down-converter.

1-4 IDENTIFICATION NUMBER

All WILTRON instruments are assigned a unique six-digit ID number, such as "205001." The first digit of this ID (2 in the example) represents the instrument's year-of-manufacture; the next two (05), its manufac-

turing "run;" and the last three (001), its serial number. Each 6600A Series sweep generator has two ID numbers assigned, one for the basic frame and one for the RF deck. The ID number for the RF deck, which provides primary identification, is affixed to the outside of the rear panel. The basic frame ID number appears on the inside of the rear panel. Please use the primary (outside) serial number when ordering parts or when corresponding with Customer Service.

1-5 OPTIONS

The following options are available for the 6600A Series sweep generators:

- **Option 1, Rack Mount.** Sweep generator comes equipped with mounting ears and chassis track slides that have a 90° tilt capability.
- **Option 2, 10 dB Step Attenuator.** Sweep generator comes supplied with a front panel or GPIB-programmable 10 dB step attenuator. Step attenuator has a 70 dB range.
- **Option 3, GPIB Interface.** Sweep generator is equipped to operate on the IEEE-488 (IEC-625) Interface Bus. With Option 3 installed, all front panel push-buttons except POWER are bus-programmable. Option 3 may be installed in the field.
- **Option 9, Main RF Connector on Rear Panel.** Sweep generator comes supplied with an SMA female connector installed on the rear panel rather than on the front panel.
- **Option 10, Auxiliary RF Output Connector (Rear Panel).** Sweep generator comes equipped with a second RF connector (SMA female) installed on the rear panel.

Its output power level is approximately 25 dB below the main connector power level, and its Maximum Levelled Power specification is derated by 1.5 dB.

- **Option 12, RF Output Interface, Sweep Generator to Model 661 Tracking Sweeper Controller.** Sweep generator comes supplied with a rear panel SMA connector for supplying a 10 dB attenuated RF sample to the Model 661 Tracking Sweeper Controller.
- **Option 13, Hardware Interface to HP 5342 or HP 5343A Microwave Counter.** Sweep generator comes supplied with a rear panel BNC connector that allows the HP counter to be used to count the marker frequency(ies).

- **Option 14, Data I/O Rear Panel Connector.** Sweep generator comes supplied with a 37-pin Data I/O connector for interfacing the Model 661 Tracking Sweeper Controller with the IEEE-488 Interface Bus. Sweep generator must also have Option 3.

1-6 SPECIFICATIONS

Guaranteed performance specifications for the multiband models of the 6600A Series Programmable Sweep Generator are provided in Figure 1-2.

1-7 CHARACTERISTICS

Operational characteristics, along with brief descriptions of input and output connectors for the 6600A Series sweep generator (all models), are given in Tables 1-1 and 1-2.

Table 1-1. "RESET" Output Power Level (Power Level Indicated on LEVEL Display when RESET is Pressed)

MODEL	POWER LEVEL (dBm)			
	Standard Model	With Opt. 2	With Opt. 10	With Opt. 2 & 10
6609A	13.0	12.5	11.5	11.0
6617A	10.0	9.0	8.5	7.5
6621A	10.0	8.7	8.5	7.2
6621A-40	16.0	14.7	14.5	13.2
6629A	10.0	8.2	8.5	6.7
6629A-40	16.0	14.2	14.5	12.7
6637A	10.0	8.2	8.5	6.7
6637A-40	16.0	14.2	14.5	12.7
6638A	7.0	5.2	5.5	3.7
6642A	0.0	N/A	N/A	N/A
6647A	10.0	8.2	8.5	6.7
6648A	7.0	5.2	3.5	3.7
6653A	6.0	2.0	3.5	0.5
6659A	6.0	2.0	4.5	0.5

UNIVERSAL SPECIFICATIONS, ALL MODELS

EXTERNAL AM INPUT: Rear panel BNC connector. 10k ohm impedance.

Sensitivity: 1 dB/V

Frequency Response (typical): DC-50 kHz

Input Impedance: 10 kΩ

Amplitude Control Range: > 13 dB

Maximum Input: 20V

EXTERNAL FM AND PHASE LOCK INPUT: Rear panel BNC connector. 10k ohm impedance.

Sensitivity: -6 MHz/V

Maximum Deviation for Modulation Frequency of:

DC-100 kHz: ±25 MHz

100-250 kHz: ±5 MHz

EXTERNAL SQUARE WAVE INPUT: Externally applied TTL-compatible square wave modulates output at dc to 50 kHz rate. Will accommodate ±6V square wave. On/Off ratio, typically 40 dB. Maximum input, ±20 volts. Rear panel BNC connector. Not available on 6642A.

POWER VARIATION WITH TEMPERATURE: ±0.5 dB/°C. Not applicable to 6642A.

RESIDUAL AM (50 kHz Bandwidth): > 50 dBc. Not applicable to 6642A.

OUTPUT CONNECTOR: Type N Female, all models except:

Model 6653A and 6659A: Ruggedized WSMA Female.

Model 6642A: WSMA Female (18-26.5 GHz); UG-599/U (26.5-40 GHz).

**SOURCE SWR SPECIFICATIONS
INDIVIDUAL MODELS**

MODEL	SOURCE SWR (50Ω)	SOURCE SWR WITH OPTIONS 2 AND 9
6609A	1.3	1.5
6617A	1.4 (≤ 2 GHz) 1.2 (> 2 GHz)	1.5
6621A, 6621A-40	1.3 (≤ 8 GHz) 1.5 (> 8 GHz)	2.0
6629A, 6629A-40	1.5	2.0
6637A, 6637A-40, 6638A	1.2 (≤ 8 GHz) 1.4 (> 8 GHz)	2.0
6642A	2.0 (18-26.5 GHz) N/A (26.5-40 GHz)	N/A
6647A, 6648A	1.4 (< 2 GHz) 1.2 (2-8 GHz) 1.4 (> 8 GHz)	2.0
6653A, 6659A	1.5 (≤ 18 GHz) 1.7 (> 18 GHz)	2.0

FREQUENCY, POWER, AND PURITY SPECIFICATIONS, INDIVIDUAL MODELS

MODEL	FREQUENCY RANGE (GHz)	OUTPUT POWER (25°C ± 5°)		POWER LEVEL ACCURACY			LEVELED POWER VARIATION		SIGNAL PURITY			FREQUENCY ACCURACY (25°C)		FREQUENCY STABILITY					MODEL
		INTERNALLY LEVELED MAXIMUM (dBm)	WITH OPT. 2, 70 dB ATTENUATOR (dBm)	LEVELED (dB)	WITH OPT. 2, 70 dB ATTENUATOR, ADD: (dB)	ATTENUATOR ACCURACY PER STEP (dB)	WITH FREQUENCY (dB)	WITH FREQUENCY OPT. 2, 70 dB ATTENUATOR (dB)	HARMONICS (dBc)	NON-HARMONICS (dBc)	RESIDUAL FM 3 (kHz pk)	CW MODE (MHz)	SWEEP MODE ≤ 50 MHz (MHz)	WITH TEMPERATURE (MHz/°C)	WITH 10% LINE VOLTAGE CHANGE (kHz)	WITH 10 dB POWER LEVEL CHANGE (kHz)	WITH 3:1 LOAD SWR (kHz)	WITH TIME, 10 MINUTES TYPICAL 4 (kHz)	
6609A	.01-2	> 13	> 12.5	±0.6	±0.8	±0.3	±0.3	±0.8	> 30	> 40	< 7	±5	±10	±1	±100	±100	±10	±200	6609A
6617A	.01-8	> 10	> 9	±0.9	±1	±0.4	±0.5	±1	> 30 (< 2 GHz) > 40 (> 2 GHz)	> 40 (< 2 GHz) > 60 (> 2 GHz)	< 7	±5	±10	±1 (< 2 GHz) ±0.5 (> 2 GHz)	±100	±100	±100	±200	6617A
6621A	2-12.4	> 10	> 8.7	±1	±1.5	±0.4	±0.5	±1.4	> 40	> 60	< 10	±10	±15	±0.5	±100	±500	±300	±200	6621A
6621A-40	2-12.4	> 16	> 14.7	±1	±1.5	±0.4	±0.5	±1.4	> 25	> 60	< 10	±10	±15	±0.5	±100	±500	±300	±200	6621A-40
6629A	8-18.6	> 10	> 8.2	±1	±1.5	±0.4	±0.5	±1.5	> 40	> 60	< 10	±10	±15	±0.5	±100	±500	±300	±200	
6629A-40	8-18.6	> 16	> 14.2	±1	±1.5	±0.4	±0.5	±1.5	> 40	> 60	< 10	±10	±15	±0.5	±100	±500	±300	±200	6629A-40
6637A	2-18.6	> 10	> 8.2	±1	±1.5	±0.4	±0.5	±1.5	> 40	> 60	< 7 (< 8 GHz) < 10 (> 8 GHz)	±10	±15	±0.5	±100	±500	±300	±200	6637A
6637A-40	2-18.6	> 16	> 14.2	±1	±1.5	±0.4	±0.5	±1.5	> 25	> 60	< 7 (< 8 GHz) < 10 (> 8 GHz)	±10	±15	±0.5	±100	±500	±300	±200	6637A-40
6638A	2-20	> 10 (≤ 18 GHz) > 7 (> 18 GHz)	> 8.2 (≤ 18 GHz) > 5.2 (> 18 GHz)	±1	±1.5	±0.7	±0.5	±1.5	> 40	> 60	< 7 (< 8 GHz) < 10 (> 8 GHz)	±10	±15	±0.5	±100	±500	±300	±200	6638A
6642A	18-40	> 5 (18-26.5 GHz) > 0 (26.5-40 GHz)	N/A	±2 (< 26.5 GHz) N/A (> 26.5 GHz)	N/A	N/A	±1 (< 26.5 GHz) N/A (> 26.5 GHz)	N/A	> 30 (< 26.5 GHz) > 20 (> 26.5 GHz)	> 60	< 30 (< 26.5 GHz) < 40 (> 26.5 GHz)	±15 (< 26.5 GHz) ±20 (> 26.5 GHz)	±25 (< 26.5 GHz) ±30 (> 26.5 GHz)	±2	±200	±500	±300	±400	6642A
6647A	.01-18.6	> 10	> 8.2	±1	±1.5	±0.4	±0.6	±1.5	> 30 (< 2 GHz) > 40 (> 2 GHz)	> 40 (< 2 GHz) > 60 (> 2 GHz)	< 7 (< 8 GHz) < 10 (> 8 GHz)	±10	±15	±1 (< 2 GHz) ±0.5 (> 2 GHz)	±100	±500	±300	±200	6647A
6648A	.01-20	> 10 (≤ 18 GHz) > 7 (> 18 GHz)	> 8.2 (≤ 18 GHz) > 5.2 (> 18 GHz)	±1	±1.5	±0.7	±0.6	±1.5	> 30 (< 2 GHz) > 40 (> 2 GHz)	> 40 (< 2 GHz) > 60 (> 2 GHz)	< 7 (< 8 GHz) < 10 (> 8 GHz)	±10	±15	±1 (< 2 GHz) ±0.5 (> 2 GHz)	±100	±500	±300	±200	6648A
6653A	2-26.5	> 10 (≤ 18 GHz) > 6 (> 18 GHz)	> 7 (≤ 18 GHz) > 2 (> 18 GHz)	±1	±2	±0.7	±1.0	±1.5	> 40	> 60	< 7 (< 8 GHz) < 10 (8 to 18 GHz) < 15 (> 18 GHz)	±20	±30	±1	±100	±500	±300	±200	6653A
6659A	.01-26.5	> 10 (≤ 18 GHz) > 6 (> 18 GHz)	> 5 (≤ 18 GHz) > 1.6 (> 18 GHz)	±1	±2	±0.7	±1.0	±1.5	> 30 (< 2 GHz) > 40 (> 2 GHz)	> 40 (< 2 GHz) > 60 (> 2 GHz)	< 7 (< 8 GHz) < 10 (8 to 18 GHz) < 15 (> 18 GHz)	±20	±30	±1 (< 2 GHz) ±0.5 (> 2 GHz)	±100	±500	±300	±200	6659A

¹ External leveling only.

² Excluding 5% band edges where specification is > 20 dBc.

³ Measured in 30 Hz-15 kHz bandwidth.

⁴ After 30 minutes warmup at selected CW frequency.

Figure 1-2. Specifications

Table 1-2. Characteristics, 6600A Series Sweep Generators

SWEEP TIME: Continuously adjustable from .01 to 99 seconds, displayed on front panel LED readout.

SWEEP MODES:

Full Sweep: Sweeps full band in one continuous frequency sweep. The high- and low-end frequency points are displayed on the front panel.

F1 to F2 Sweep: Sweeps between user-selected frequencies (F1 and F2), which are displayed on the front panel.

M1 to M2 Sweep: Sweeps between user-selected frequencies (M1 and M2), which are displayed on the front panel.

ΔF F0 Sweep: Sweeps symmetrically about a center frequency (F0) that is user-selected. F0 frequency and sweep-width frequency range are simultaneously displayed on the front panel.

ΔF F1 Sweep: Sweeps symmetrically about a center frequency (F1) that is user-selected. F1 frequency and sweep-width frequency range are simultaneously displayed on the front panel.

CONTINUOUS WAVE (CW) MODES:

CW F0	} Fixed frequency CW output at the respective F0, F1, F2, M1, or M2 frequency point. The frequency of the CW signal is displayed on a front-panel LED readout.
CW F1	
CW F2	
CW M1	
CW M2	

FINE-FREQUENCY CONTROL:

Frequency Vernier controls are available and may be used with a microwave counter to finely adjust (1) the output frequency in any CW mode or (2) the center frequency in either ΔF sweep mode. Without changing the frequency appearing on the applicable numeric

display, these pushbuttons will change the output frequency by up to ± 10 MHz for all models except the 6642A, 6653A, and 6659A. For these three models, the output frequency can be changed by up to ± 25 MHz.

TRIGGER MODES:

Automatic: Sweep recurs automatically.

Line: Sweep recurs in sync with the line frequency or in sync with multiples of the line frequency.

External or Single: Sweep recurs when triggered. Triggering can be accomplished either from the front panel or by applying an external pulse to the rear panel.

Manual: Frequency may be swept manually between upper and lower frequency limits, using the front-panel MANUAL SWEEP control.

MARKERS:

Video: Positive video pulse(s). Markers appear at frequencies M1, M2, and F0, depending upon sweep mode. In the FULL, F1-F2, and ΔF F1 modes, three markers are available. In the ΔF F0 mode, two markers (M1 and M2) are available. And, in the M1-M2 mode, one marker (F0) is available. The frequency and amplitude of the marker(s) may be controlled from the front panel.

RF: Negative RF pip(s). Markers appear at frequencies M1, M2, and F0, as described for Video above. The frequency and amplitude of the marker(s) may be controlled from the front panel.

Intensity: Intensity dot(s) are created when the sweep is made to dwell momentarily at the marker frequency(ies). No connection between the sweep generator and the CRT Z-axis is

Table 1-2. Characteristics, 6600A Series Sweep Generator (Continued)

required. Markers appear at frequencies M1, M2, and F0, as described for "Video" above. The frequency of the marker(s) may be selected from the front panel.

LEVELING MODES:

Internal: The output power is sampled internally and used to provide leveled RF power at the RF OUTPUT connector.

Detector: The output power may be sampled externally using a coupler and detector, and used to provide leveled RF power at the device under test.

Power Meter: The output power may be sampled externally using a coupler and a power meter, and used to provide leveled RF power at the device under test.

SHIFTED FUNCTIONS:

Alternating Sweep: Sweep generator alternates between any two of the five frequency-sweep ranges: Full, F1-F2, M1-M2, ΔF F0, ΔF F1. When used with a compatible network analyzer, such as the WILTRON 560A, this function allows two sweeps to be input into the same channel through a single RF detector or SWR Autotester.

CW Filter, Enable-Disable: Provides for switching the CW filter out of the YIG oscillator tuning circuit. This filter is automatically inserted for CW and narrow (≤ 50 MHz) sweep modes.

CW Ramp, On-Off: Provides a 0-10V horizontal sweep ramp during CW modes. When the sweep generator is used with the WILTRON Model 560 or 560A Scalar Network Analyzer, this sweep ramp causes the network analyzer to display a trace (rather than

a dot) when the sweep generator outputs a CW frequency.

External Sweep: Provides for sweeping the output frequency using an externally supplied sweep ramp, which is input via the rear panel EXT SWEEP connector.

SELF TEST: Diagnostic self-test routines are accomplished each time the unit is turned on and when the front-panel SELF TEST pushbutton is pressed. In the event of a self-test failure, an error code is displayed on front-panel LED readouts. If the unit passes, the word PASS is indicated on an LED readout.

EXTERNAL LEVELING CONTROL (ALC):

The gain of the external leveling input (detector or power meter) may be calibrated from the front panel for all models except 6642A; the use of an external indicating device such as an oscilloscope is not necessary.

RESET: Sweep generator operation in either the local (front panel) or remote (GPIB) operational mode can be reset to a predetermined state by pressing the front panel RESET pushbutton.

GPIB OPERATION: All front-panel push-buttons except POWER can be programmed over the IEEE-488 Interface Bus (GPIB). Front-panel indicators light when:

1. the sweeper is under GPIB (remote) control.
2. Local Lockout is programmed.
3. a Service Request (SRQ) is initiated.
4. the sweeper is addressed to either Talk or Listen.

A chart showing GPIB subset capability is given in Figure 3-30.

Table 1-2. Characteristics, 6600A Series Sweep Generators (Continued)

INPUT/OUTPUT CONNECTORS:

Horizontal Output: 0 to 10 volts during all sweep and CW modes (if CW RAMP is activated). $<100\Omega$ impedance.

Seq Sync Output: Positive TTL-level pulse during sweep retrace.

Retrace Blanking (+) Output: +5 volt, TTL-compatible pulse during retrace blanking.

Retrace Blanking (-) Output: -5 volt pulse during retrace blanking.

Marker Output: 0 to +5 volt pulse when video marker is selected. Pulse amplitude depends upon front panel MARKERS AMPLITUDE control. $1\text{ k}\Omega$ impedance.

Bandswitch Blanking Output: ± 5 volts, depending upon BANDSWITCH BLANKING switch, during oscillator band-switching. $<100\Omega$ impedance. Not used in Single-Band models.

1V/GHz Output: 1 volt per GHz of output frequency (.5V/GHz for 6636A and 6640A). $<100\Omega$ impedance.

Penlift Output: Normally-open relay contacts for lifting recorder pen during retrace. Internal jumper available for normally-closed contacts.

Sweep Trigger Input: When TRIGGER-EXT OR SINGLE pushbutton is engaged, an externally applied clock pulse with the below-listed characteristics triggers a sweep upon closure-to-ground.

Amplitude: 4 to 25 Vpk
 Pulse Width: $>1\ \mu\text{s}$
 Fall Time: $<5\ \mu\text{s}$
 Polarity: Low true

Sweep Dwell Input: +5V (maximum) TTL pulse causes frequency sweep to

dwell. Provides interface for HP 8410 Network Analyzer.

External AM Input: Provides for amplitude modulation of the output signal. $10\text{ k}\Omega$ input impedance and 1V/dB input sensitivity.

External FM and Phase Lock Input: Provides for frequency modulation of the output signal. $10\text{ k}\Omega$ input impedance and -6 MHz/V input sensitivity.

External Square Wave Input: TTL-compatible input that allows a ± 10 volt (maximum) square wave to modulate the RF output signal. Input square wave frequency from dc to 50 kHz.

External Sweep Input: Allows a 0 to 10 volt external sweep ramp to sweep the output frequency. $10\text{ k}\Omega$ input impedance.

NONVOLATILE STORAGE: Front-panel control settings are retained in an internal memory (storage) when the ac power is turned off. When the ac power is turned on again, the previously-stored control settings are returned. The internal memory is powered by a rechargeable battery. Battery charge will last approximately 20 days when the sweeper is turned off and will be automatically recharged when the sweeper is turned on again.

INPUT POWER: 100, 115-120 Vac (+5%, -10%) at 2.0A rms or 220, 230-240 Vac (+5%, -10%) at 1.0A rms, 44-68 Hertz.

OPERATING TEMPERATURE RANGE: 0 to 50 degrees centigrade.

PHYSICAL:

Height: 13.34 cm (5.25 inches)
 Width: 43.18 cm (17 inches)
 Depth: 47.6 cm (18.75 inches)
 Weight: 15.08 kg (33.5 pounds)

SECTION II

INSTALLATION

2-1 INTRODUCTION

This section provides information on initial inspection, preparation for use, and General Purpose Interface Bus (GPIB) interconnections. Also included is information concerning reshipment and storage of the sweep generator.

2-2 INITIAL INSPECTION

Inspect the shipping container for damage. If the container or cushioning material is damaged, retain until the contents of the shipment have been checked against the packing list and the instrument has been checked for mechanical and electrical operation.

If the sweep generator is damaged mechanically, notify your local sales representative or WILTRON Customer Service. If either the shipping container is damaged or the cushioning material shows signs of stress, notify the carrier as well as WILTRON. Keep the shipping materials for carrier's inspection.

2-3 PREPARATION FOR USE

Preparation for use consists of checking that the sweep generator is set for the correct line voltage. The line-voltage module on rear panel enables the sweep generator to be used with any of four international line voltages: 100, 115/120, 220, or 230/240. Before leaving the factory, each sweep generator is preset and tagged for the line voltage present in the customer's area. If the actual line voltage is different from that stated on the

tag, the following procedure gives instructions for changing the line-voltage selector card.

- a. Refer to Figure 2-1. Disconnect the power cord from the voltage selector module ① and slide cover ② down to gain access to the fuse compartment.
- b. To select a different line voltage:

1. Pull on FUSE PULL ③ and remove line fuse ④ and PC board ⑤.

NOTE

The PC board is tightly secured within the module housing. It may be necessary to use needle-nose pliers or a similar tool as a pry.

2. Using the example for 115/120 Vac operation (Figure 2-1) as a guide, reinstall the PC board. For the correct installation of this board, the desired line-voltage callout should be located:
 - a. adjacent to the input receptacle and
 - b. facing toward the BNC connector-bank.
3. Push the FUSE PULL back to its normal position and insert a fuse of the proper value (as indicated on the right side of the module) into the fuse holder.

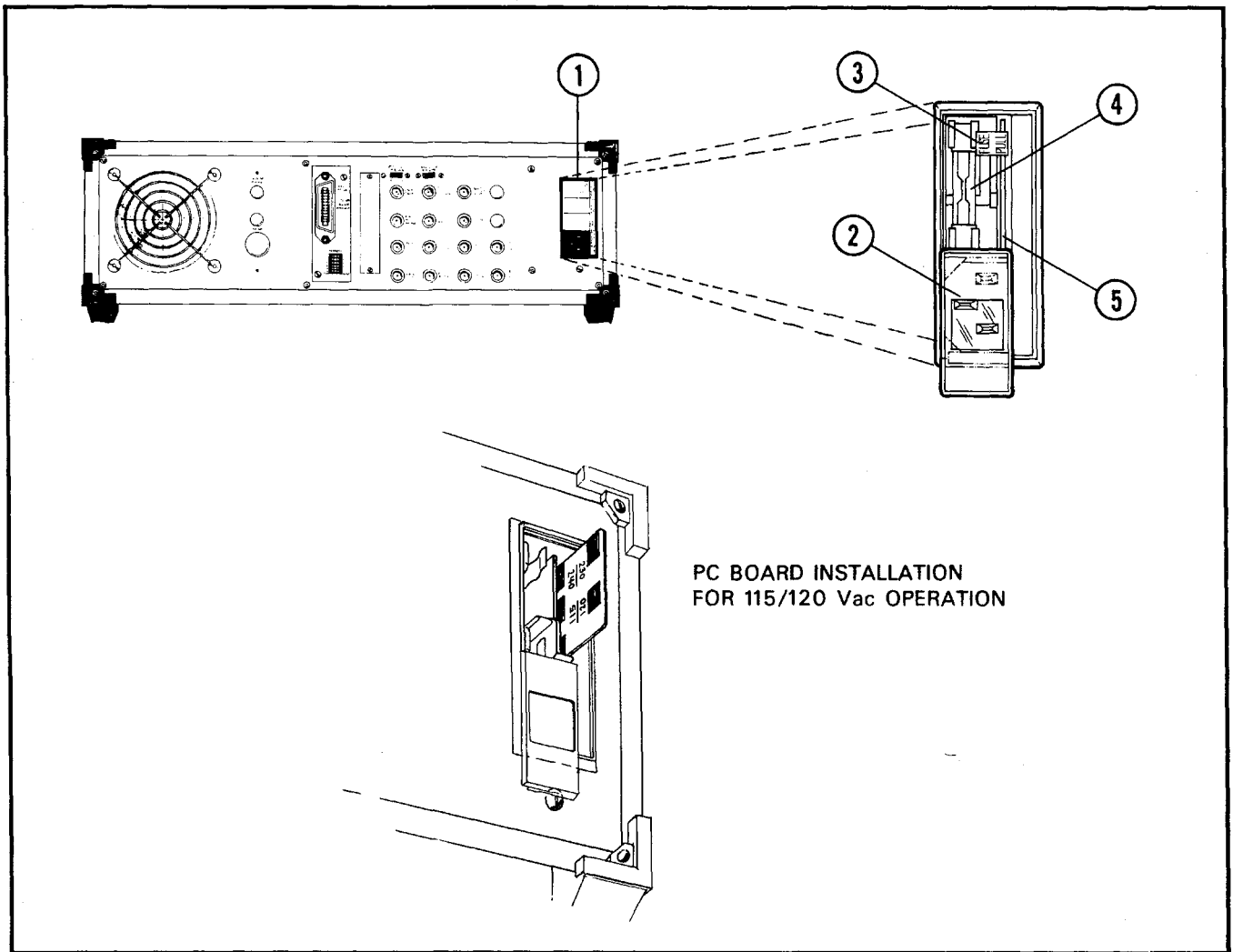

Figure 2-1. Line Voltage Selector Module

2-4 GPIB SETUP AND INTERCONNECTION

With Option 3 installed, the sweep generator is capable of providing automated microwave measurements via the GPIB. Specific GPIB information — including interface connections, cable requirements, and addressing instructions — is contained in the following paragraphs.

2-4.1 Interface Connector

Interface between the sweep generator and other devices on the GPIB is via a 24-wire interface cable. The interface cable is specifically constructed with each end con-

taining a connector shell with two connector faces. These double-faced connectors allow for parallel connection of two or more cables to a single device. Figure 2-2 shows the pin assignments for the Type 57 GPIB connector, installed on the rear panel.

2-4.2 Cable Length Restrictions

The GPIB system can accommodate up to fifteen instruments at any one time. To achieve design performance on the bus, the proper timing and voltage level relationships must be maintained. If either the cable length between separate instruments or the accumulated cable length between all instruments is too long, the data and control lines

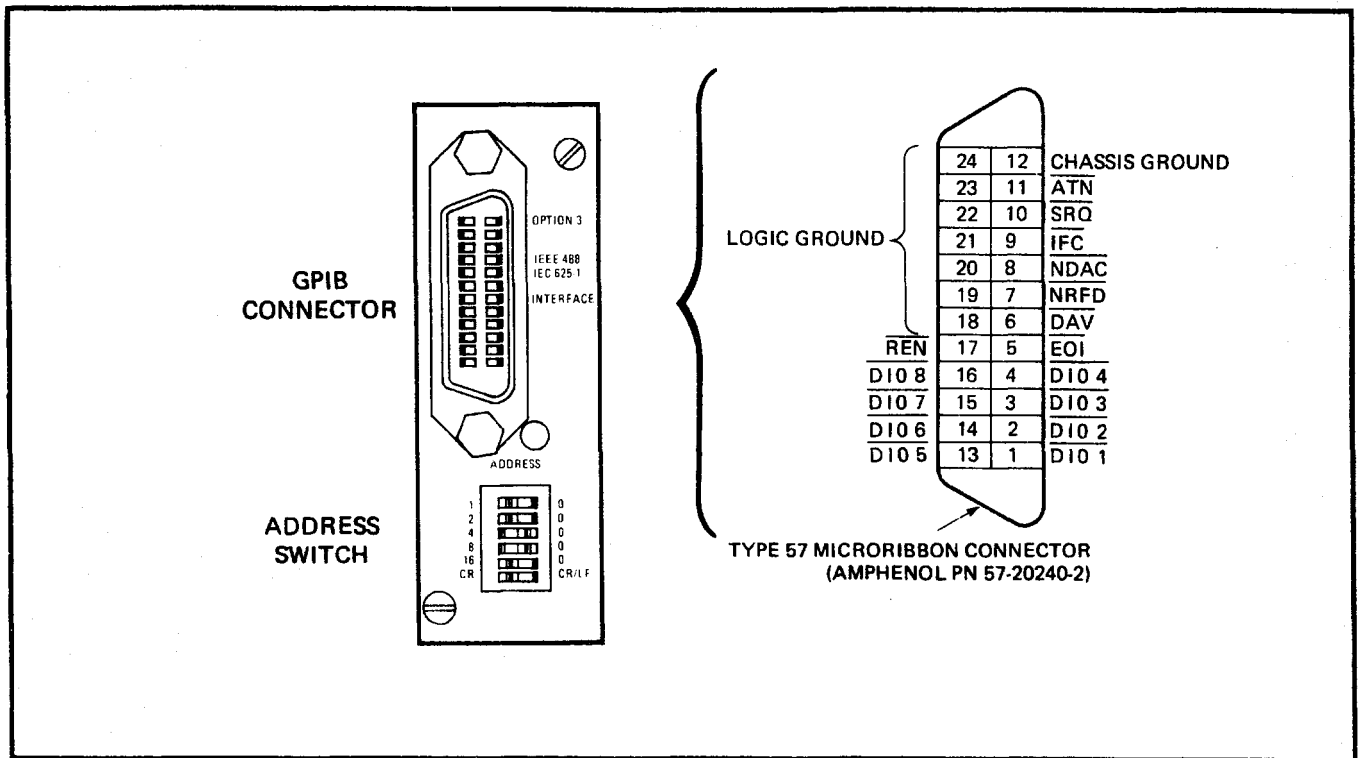

Figure 2-2. Option 3 Panel (ADDRESS Switch and GPIB Connector)

cannot be driven properly and the system may fail to perform. Cable length restrictions are as follows:

- No more than 15 instruments may be installed on the bus.
- Total accumulative cable length in meters may not exceed 2 times the number of bus instruments, or 20 meters – whichever is less.

2-4.3 GPIB Interconnection

The only interconnection required for GPIB operation is between the sweep generator and the controller. To accomplish this interconnection, a special cable is required. This cable – WILTRON Part No. 2000-1, -2, or -4 (1, 2, or 4 meters in length) – is available from the factory.

2-4.4 GPIB Address

The sweep generator is shipped from the factory preset to address 5. If a different

address is desired, the ADDRESS switches on the Option 3 panel (Figure 2-2) provide for the selection of any address number between 0 and 30. Figure 2-3 provides a tabulation of the available address numbers, and Figure 2-4 provides an example of how an address number is selected.

2-4.5 Data Delimiting (CR-CR/LF Switch)

On the GPIB, data delimiting is accomplished using either the carriage return (CR) or both the carriage return and the line feed (CR/LF) ASCII characters, depending upon the requirements of the instrument used as system controller. For example, the PET 2001 requires CR. The HP 9825A requires CR/LF, while the WILTRON 85 and the Tektronix 4051 can use either CR or CR/LF.

To provide ease in selecting the proper data-delimiting character for the controller in use, a switch is provided on the rear Option 3 panel. To use this switch, simply press the rocker arm to the position of the required delimiting character (Figure 2-4).

		(MSB)					(LSB)						
Decimal Address	ASCII Character	16	8	4	2	1	Decimal Address	ASCII Character	16	8	4	2	1
0	Space	0	0	0	0	0	16	0	1	0	0	0	0
1	!	0	0	0	0	1	17	1	1	0	0	0	1
2	"	0	0	0	1	0	18	2	1	0	0	1	0
3	#	0	0	0	1	1	19	3	1	0	0	1	1
4	\$	0	0	1	0	0	20	4	1	0	1	0	0
5	%	0	0	1	0	1	21	5	1	0	1	0	1
6	&	0	0	1	1	0	22	6	1	0	1	1	0
7	'	0	0	1	1	1	23	7	1	0	1	1	1
8	(0	1	0	0	0	24	8	1	1	0	0	0
9)	0	1	0	0	1	25	9	1	1	0	0	1
10	*	0	1	0	1	0	26	:	1	1	0	1	0
11	+	0	1	0	1	1	27	;	1	1	0	1	1
12	,	0	1	1	0	0	28	<	1	1	1	0	0
13	-	0	1	1	0	1	29	=	1	1	1	0	1
14	.	0	1	1	1	0	30	>	1	1	1	1	0
15	/	0	1	1	1	1							

Switch ON = 1
Switch OFF = 0

Figure 2-3. Available Address Codes and Corresponding ADDRESS Switch Positions

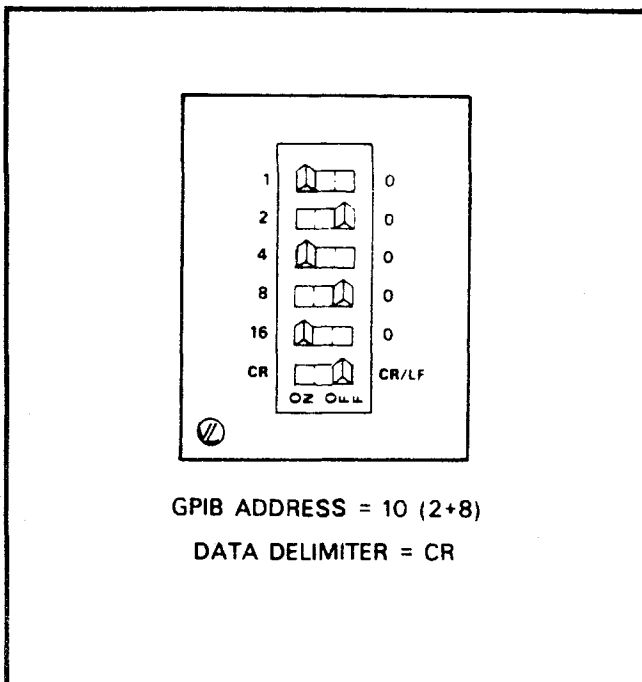

Figure 2-4. Address Selection

2-4.6 Option 3 (GPIB) Installation

Option 3, which consists of the A1 PCB and the A18 GPIB Connector Assembly, may be installed in the field, as follows:

- a. Remove the rear panel cover plate and install the A18 Connector Assembly. See Figure 3-20, index number 3, for location.
- b. Connect the A18P1 connector to A14P4, on the motherboard. See Figure 7-125 for location.
- c. Install the A1 PCB into its marked slot in the 660-D-8000 Mainframe Assembly. See Figure 6-1, index number 1, for location.

2-5 PREPARATION FOR STORAGE AND/OR SHIPMENT

Instructions for preparing the sweep generator for storage, shipment, or both are provided in paragraphs 2-5.1 and 2-5.2.

2-5.1 Preparation for Storage

Preparation for storage involves cleaning the unit, packing the inside of the unit with moisture-absorbing dessicant crystals, and storing the unit in a temperature environment between -40 and +70 degrees centigrade.

2-5.2 Preparation for Shipment

To provide maximum protection against damage in transit, the sweep generator should be repackaged in the original shipping container. If this container is no longer available and the sweep generator is being returned to WILTRON for repair, contact WILTRON Customer Service and a new shipping container will be sent to you free of charge. In the event neither of these two options is possible, the following paragraphs provide instructions for packaging and shipment.

- a. Use a Suitable Container. Obtain a corrugated cardboard carton with a 275-pound test strength and inside dimensions of no less than six inches more than the instrument dimensions; this allows for cushioning.

- b. Protect the Instrument. Surround the instrument with polyethylene sheeting to protect the finish.
- c. Cushion the Instrument. Cushion the instrument on all sides by tightly packing dunnage or urethane foam between the carton and the instrument; allow a minimum of three inches of dunnage on all sides.
- d. Seal the Container. Seal the carton by using either shipping tape or an industrial stapler.
- e. Address the Container. If the instrument is being returned to WILTRON for service, mark the WILTRON address and your return address on the carton in one or more prominent locations. The WILTRON address is:

WILTRON Company
ATTN: Customer Service
825 E. Middlefield Road
Mountain View, CA 94043

POWER, SELF TEST, and RESET Pushbuttons - Provide for turning power on/off, performing self test, and resetting front-panel controls to a known state. Individual pushbuttons are described in paragraph 3-2.7.

BUS ADRS/RETURN TO LOCAL Pushbutton and GPIB Indicators - Provide for the display of GPIB status and address information, plus, if the sweep generator is in the GPIB mode of operation, return to local (front panel) control. The pushbutton and indicators are described in paragraph 3-2.8.

RF OUTPUT Pushbutton, Indicators, and Connector - Provide for the output and control of the RF output function. Individual pushbuttons and indicators, along with the connector, are described in paragraph 3-2.5.

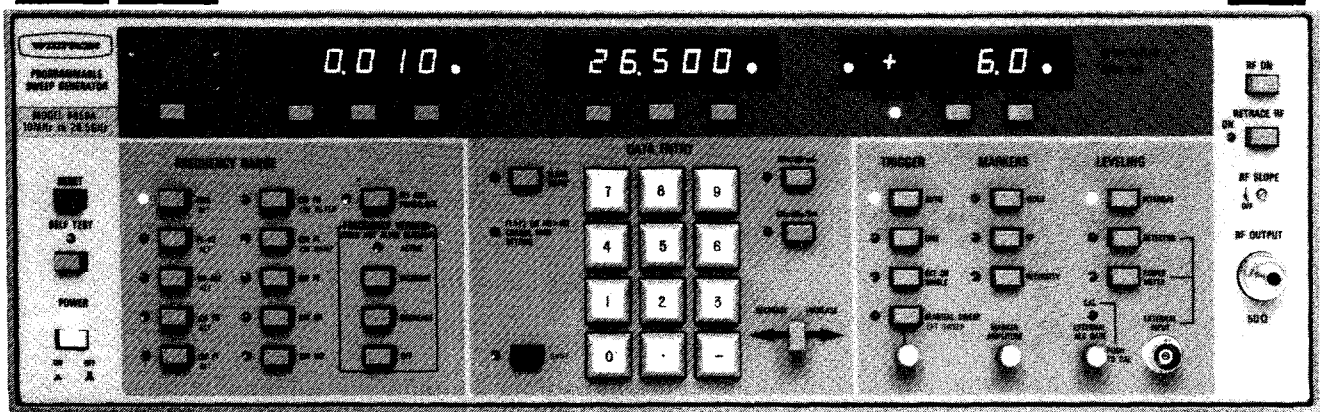

FREQUENCY RANGE Pushbuttons - Control the frequency sweep and CW output of the sweep generator. Individual pushbuttons are described in paragraph 3-2.2.

DATA ENTRY and SHIFT Pushbuttons - The data entry controls provide for inputting frequency, sweep time, and output-power level information. The SHIFT pushbutton provides alternate functions for certain controls. Individual pushbuttons are described in paragraph 3-2.1.

MARKERS Pushbuttons - Provide for markers. Individual pushbuttons are described in paragraph 3-2.4.

TRIGGER Pushbuttons - Provide for sweep triggering. Individual pushbuttons are described in paragraph 3-2.3.

LEVELING Pushbuttons and Connector - Provide for RF output leveling. Individual pushbuttons, along with the connector, are described in paragraph 3-2.5.

Figure 3-1. Sweep Generator Front Panel Controls

SECTION III OPERATION

3-1 INTRODUCTION

This section contains information on the front and rear panel controls and connectors, plus a description of the sweep generator self-test feature. Also included are operational checkout procedures and a description of the Option 3 GPIB command codes.

3-2 FRONT PANEL CONTROLS

The front panel controls are grouped by function, as shown in Figure 3-1. Detailed descriptions of individual controls within each group are given in paragraphs 3-2.1 thru 3-2.8.

3-2.1 DATA ENTRY Pushbuttons

There are five discrete frequency parameters (F0, F1, F2, M1, and M2) and one sweep width parameter (ΔF) – plus the sweep time and RF-output power level parameters – used to control the operation of the sweep generator. The DATA ENTRY pushbuttons (Figure 3-2) provide for entering new values for these parameters.

To provide an overview, several examples of how these pushbuttons are used to accomplish data entry are given in Figure 3-3. Individual DATA ENTRY pushbuttons are described in subparagraphs a. through f.

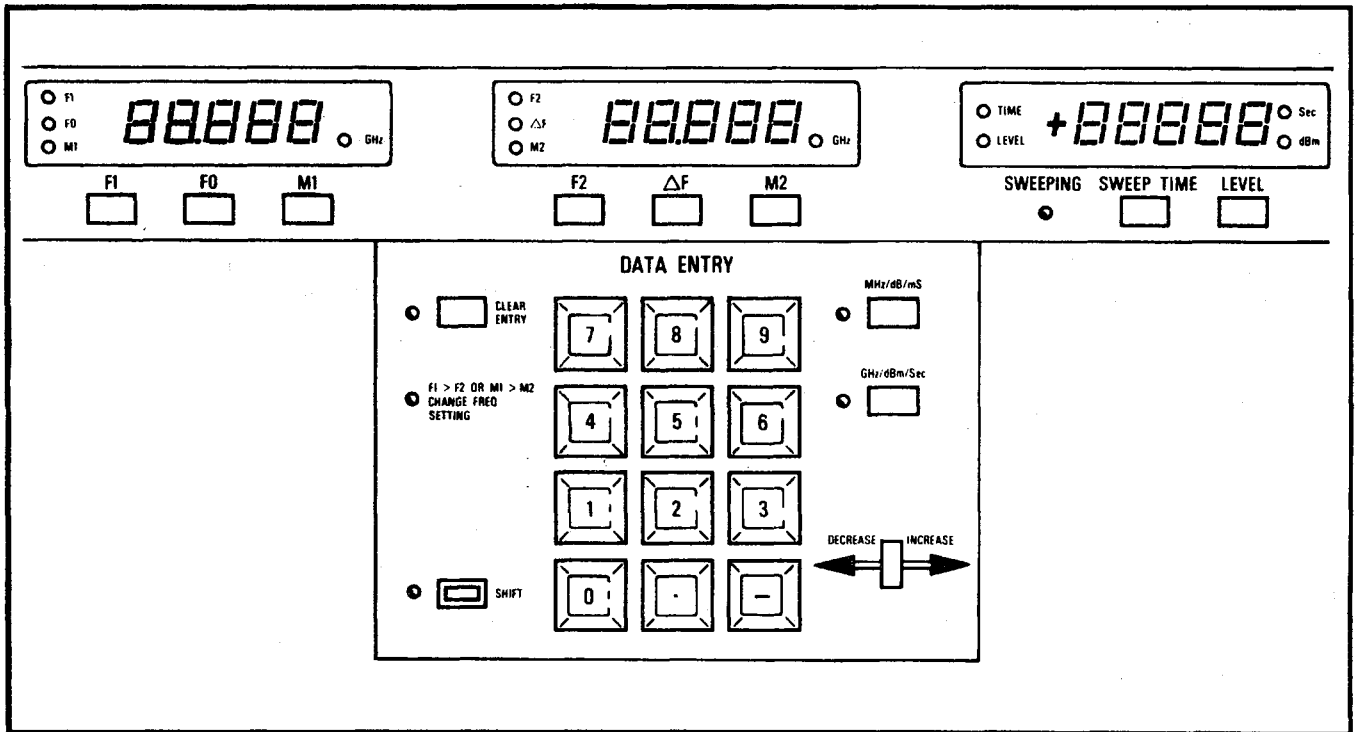

Figure 3-2. DATA ENTRY Pushbuttons

1. To enter a new F1 parameter of 6600 MHz, proceed as follows:

Press $\boxed{F1}$ + $\boxed{6}$ $\boxed{6}$ $\boxed{0}$ $\boxed{0}$ + $\boxed{MHz/dB/mS}$

or

Press $\boxed{F1}$ + $\boxed{6}$ $\boxed{6}$ $\boxed{8}$ + $\boxed{GHz/dB/Sec}$

The display above the F1 pushbutton will read:

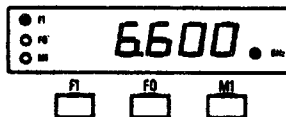

2. To enter a new SWEEP TIME parameter of 50 ms, proceed as follows:

Press $\boxed{SWEEP TIME}$ + $\boxed{5}$ $\boxed{0}$ + $\boxed{MHz/dB/mS}$

or

Press $\boxed{SWEEP TIME}$ + $\boxed{0}$ $\boxed{5}$ $\boxed{0}$ + $\boxed{GHz/dB/Sec}$

The display above the SWEEP TIME pushbutton will read:

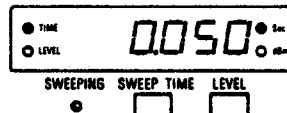

3. To enter a new RF level parameter of 5 dBm, proceed as follows:

Press \boxed{LEVEL} + $\boxed{5}$ + $\boxed{GHz/dB/Sec}$

The display above the LEVEL pushbutton will read:

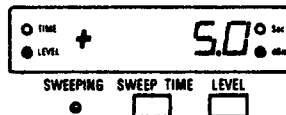

4. To change the RF power level, two methods are available: (1) a new power level may be selected using the example shown in 3, above, or (2) a value in dB may be added to or subtracted from the present power level; the algebraic sum or difference of this arithmetical process will appear on the display in dBm. Examples are shown in a and b, below.

a. To subtract 0.3 dB from the power level selected in 3, above, proceed as follows:

Press \boxed{LEVEL} + $\boxed{-}$ $\boxed{0}$ $\boxed{3}$ + $\boxed{MHz/dB/mS}$

The display above the LEVEL pushbutton will read:

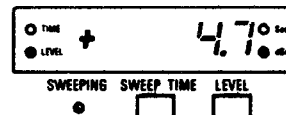

b. To add 2 dB to the power level selected in 4a., above, proceed as follows:

Press \boxed{LEVEL} + $\boxed{2}$ + $\boxed{MHz/dB/mS}$

The display above the LEVEL pushbutton will read:

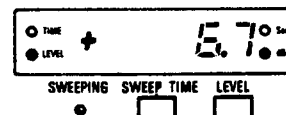

Figure 3-3. How to Enter Parameter Data (Examples)

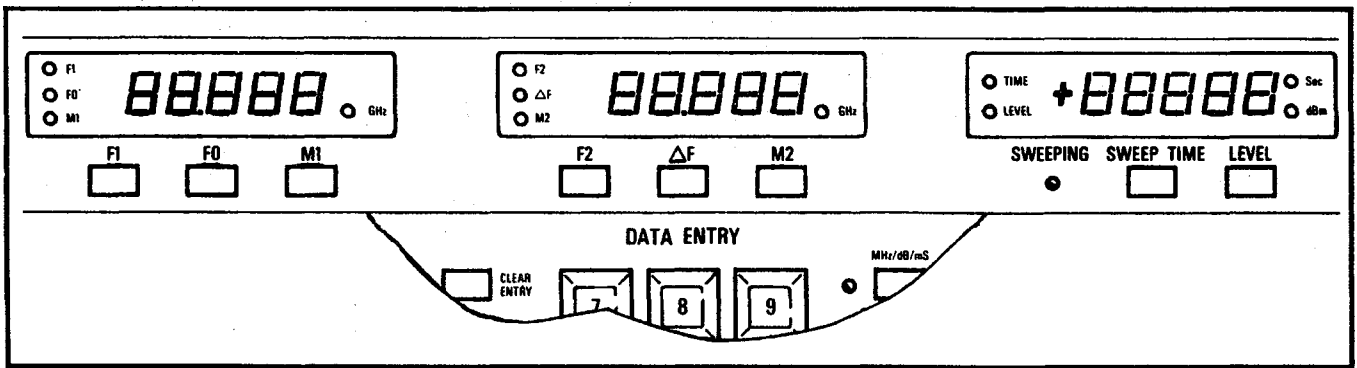

Figure 3-4. F1, F0, M1, F2, ΔF, M2, SWEEP TIME and LEVEL Pushbuttons and SWEEPING Indicator

a. F1, F0, M1, F2, ΔF, M2, SWEEP TIME, and LEVEL Pushbuttons and SWEEPING Indicator (Figure 3-4).

1. The pushbuttons enable the selected parameter's value to be changed via the DATA ENTRY keypad or the INCREASE/DECREASE lever or to be monitored via the appropriate LED readout. The parameter that is selected for either changing or monitoring is hereafter known as the **selected parameter**.
2. The SWEEPING Indicator lights during the forward portion of the frequency sweep. The indicator is out during retrace.

b. DATA ENTRY Keypad (Figure 3-5). The DATA ENTRY keypad is used to change

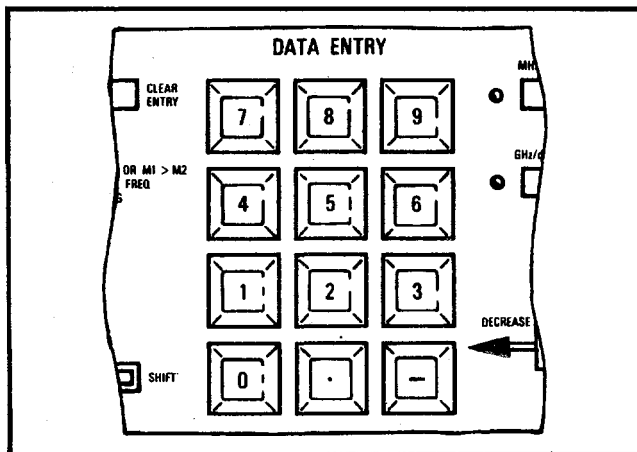

Figure 3-5. DATA ENTRY Keypad

the value of the selected frequency, sweep time, or level parameter. When the selected parameter is frequency (F1, F0, M1, F2, ΔF, or M2), the new value may be entered in either MHz or GHz. When the selected parameter is sweep time, the new value may be entered in either seconds or milliseconds. And, when the selected parameter is power level, the new value may be entered in either dB or dBm.

- c. INCREASE/DECREASE Lever (Figure 3-6). When enabled by a parameter pushbutton (F1, SWEEP TIME, LEVEL, etc.), this lever may be used to increase or decrease the parameter's value. The length of lever travel, either right or left, determines the rate at which the parameter's value increases or decreases. To increase or decrease the parameter's value in one-increment steps, "tap" the switch in the direction of desired change. When the lever is "tapped," a frequency parameter will change in 1 MHz increments. An RF level parameter will

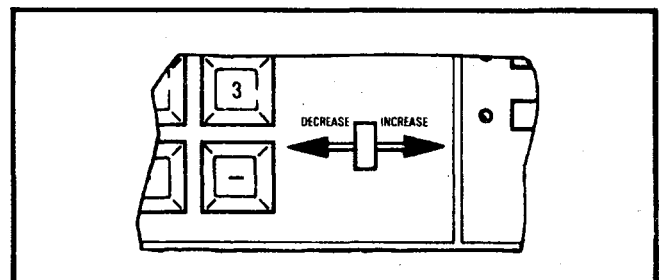

Figure 3-6. INCREASE/DECREASE Lever

change in 0.1 dB increments. And, a sweep time parameter will change in 1 ms increments between .01 and 1.0 seconds, 0.1-second increments between 1 and 10 seconds, and 1-second increments between 10 and 99 seconds.

NOTE

For SWEEP TIME, move the lever toward DECREASE to increase time, and toward INCREASE to decrease time.

d. MHz/dB/mS and GHz/dBm/Sec Pushbuttons (Figure 3-7). These two pushbuttons are data string terminators. That is, they mark the end of a parameter-input entry, and they assign the appropriate units (GHz, dBm, mS, etc.) to the entry. However, whereas

- a frequency parameter may be ended in either MHz or GHz, the value is always displayed in GHz.
- a sweep time parameter may be ended in either seconds (Sec) or milliseconds (mS), the value is always displayed in seconds.
- a power level parameter may be ended in either dB or dBm, the value is always displayed in dBm. The dB terminator pushbutton allows the displayed power level parameter to be either added to or subtracted from in dB's. When the dB terminator is used, the sweep generator performs the calculations that convert the out-

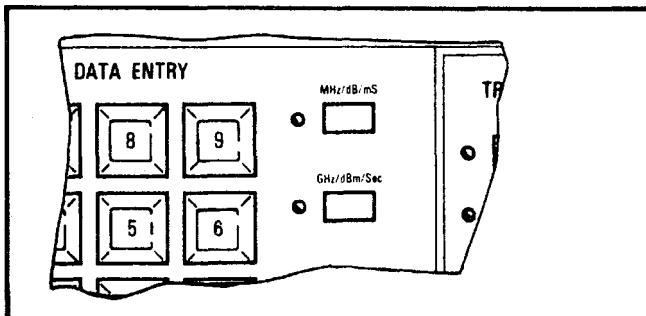

Figure 3-7. MHz/dB/mS and GHz/dBm/Sec (Terminator) Pushbuttons

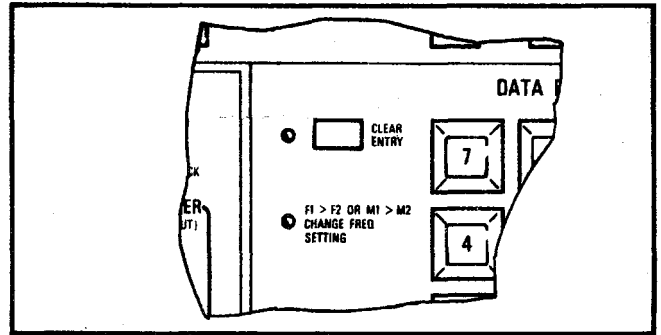

Figure 3-8. CLEAR ENTRY Pushbutton and F1>F2 OR M1>M2 Indicator

put power to a value in dBm. Example 4 in Figure 3-3 shows the use of the dB terminator pushbutton.

e. CLEAR ENTRY Pushbutton and Indicator and F1>F2 OR M1>M2 CHANGE FREQUENCY SETTING Indicator (Figure 3-8).

1. The CLEAR ENTRY pushbutton clears the keypad of an illegal or incomplete data entry (described below), and allows a new value to be entered.
2. The CLEAR ENTRY indicator flashes when an illegal or incomplete data entry has been attempted. (In addition, an illegal entry causes the LED readout displaying the illegal entry to flash; an incomplete entry causes both data terminator pushbutton indicators (Figure 3-7) to flash.)
3. The F1>F2 OR M1>M2 CHANGE FREQ SETTING indicator, along with the two LED readouts displaying frequency, flashes when a "backward" sweep is attempted. A backward sweep is when the respective value of F2 or M2 is less than that of F1 or M1. To clear a backward sweep, either re-enter the frequency values so that F1 or M1 is less than F2 or M2 or select a different frequency range.

An illegal entry is one in which a frequency, sweep time, or output-power level value beyond the range of the sweep generator is

entered via the keypad. When this occurs, the CLEAR ENTRY pushbutton must be used to clear the keypad before the error can be corrected.

An incomplete entry is one in which a parameter value is entered on the keypad and the entry is not terminated with a terminator pushbutton (Figure 3-7). When this occurs, the error can be corrected by pressing the appropriate terminator pushbutton or by pressing the CLEAR ENTRY pushbutton and re-entering the data.

f. SHIFT Pushbutton (Figure 3-9). Provides additional functions, designated by blue lettering, for the pushbuttons described below. When SHIFT is pressed, the numeric displays and LED indicators will go out, except for the currently active SHIFT functions. Pressing SHIFT again returns the displays and indicators to their unshifted (normal) indications – no parameters are changed.

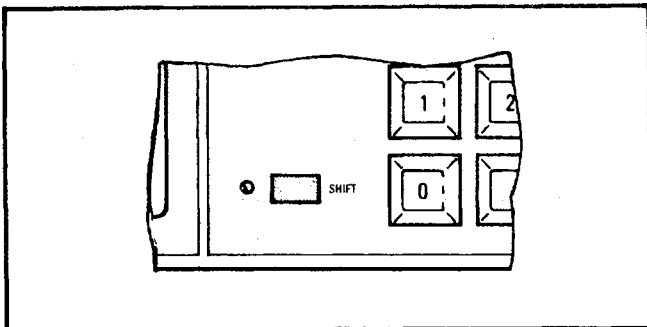

Figure 3-9. SHIFT Pushbutton

1. ALT Pushbuttons (Figure 3-10). Cause the RF output to alternate between any two of the five available sweep ranges (FULL, F1-F2, M1-M2, ΔF F0, ΔF F1). The two sweeps (A and B) are selected, and their start/stop parameters set, in the normal manner (paragraph 3-2.2a). The A (primary) sweep is chosen first, the SHIFT pushbutton is pressed, then the B (alternating) sweep is chosen. After the B sweep is chosen, the numeric displays and LED indicators will return to their unshifted state; the LED indicators associated with the A and B sweep ranges will alternately flash on and off.

When using the alternating sweeps, the following apply:

- (a) Frequency markers (VIDEO, RF, and INT) are available and can be set or changed while an alternating sweep is in progress. Marker frequencies can be set on either network analyzer trace. A marker frequency that is changed on one trace will dynamically move to the correct frequency point on the other trace.
- (b) When the INCREASE/DECREASE lever is used, it temporarily halts sweep alternations and leaves the A sweep displayed on the network analyzer or oscilloscope. When the lever is released, sweep alternations resume.
- (c) If the A or B (or both) sweep is to be a CW frequency, select a ΔF mode and set the ΔF frequency for 0 MHz.
- (d) Neither an external nor a manual sweep can be used with an ALT sweep mode. If EXT SWEEP or MANUAL SWEEP has been selected, the microprocessor will ignore any attempt to select an ALT sweep. Conversely, if an ALT sweep has been selected, the microprocessor will ignore attempts to select EXT SWEEP or MANUAL SWEEP.

To exit the alternating sweep mode, press any frequency range pushbutton (including CW).

2. CW FILTER Pushbutton (Figure 3-11). Provides enable/disable, conditional-in/unconditional-out control over the CW filter located in the YIG oscillator tuning circuit. When enabled (LED on), this pushbutton causes the CW filter to be switched-in for CW and narrow (≤ 50 MHz) sweep modes, and

not inserted otherwise. Conversely, when CW FILTER is disabled (LED off), it causes the CW filter to be unconditionally switched-out of the YIG tuning circuit. CW FILTER is selected by first pressing SHIFT, then this pushbutton. Approximately 1 second after pressing CW FILTER, the front panel will automatically return to its unshifted (normal) state. RESET (default) state: Enabled (On).

NOTE

The CW FILTER pushbutton becomes disabled (LED off) when an alternating (ALT) sweep mode is selected. When the ALT mode is exited, the CW FILTER pushbutton resumes its previously selected state.

3. CW RAMP Pushbutton (Figure 3-11). Provides a 0-10V HORIZ OUTPUT sweep ramp for all CW modes (CW F0, CW F1, CW F2, etc.). This pushbutton should be activated (LED on) when the sweep generator is used with a Model 560 or 560A Scalar Network Analyzer; otherwise, the pushbutton should be off. CW RAMP is selected by first pressing SHIFT, then this pushbutton. Approximately 1 second after pressing CW RAMP, the front panel will automatically return to its unshifted (normal) state. RESET (default) state: Off.
4. EXT SWEEP Pushbutton (Figure 3-14). Provides for sweeping the output frequency using an external sweep ramp, which is supplied via the rear panel EXT SWEEP connector. EXT SWEEP is selected by first pressing SHIFT, then this pushbutton. Approximately 1 second after pressing EXT SWEEP, the front panel will automatically return to its unshifted (normal) state. Pressing any other TRIGGER pushbutton will deactivate EXT SWEEP. RESET (default) state: Off.

3-2.2 FREQUENCY RANGE Pushbuttons

The FREQUENCY RANGE pushbuttons are used to

- select the sweep generator's operational mode – either sweep or CW;
- apply fine-frequency vernier corrections to output frequency in the selected CW mode or to center frequency in the selected ΔF sweep mode;
- apply frequency modulation to or phase-lock control over output frequency in the selected CW output mode.

Individual FREQUENCY RANGE pushbuttons are described below.

- a. FULL, F1-F2, M1-M2, ΔF F0, and ΔF F1 Pushbuttons (Figure 3-10). These pushbuttons select the sweep mode as follows:

FULL: Selects a mode in which the frequency sweep is from the sweep generator's lower to its upper frequency limit. When FULL is engaged, its indicator lights, the lower frequency limit appears on the F1-F0-M1 LED readout, and the upper frequency limit appears on the F2- ΔF -M2 LED readout. RESET (default) state: On.

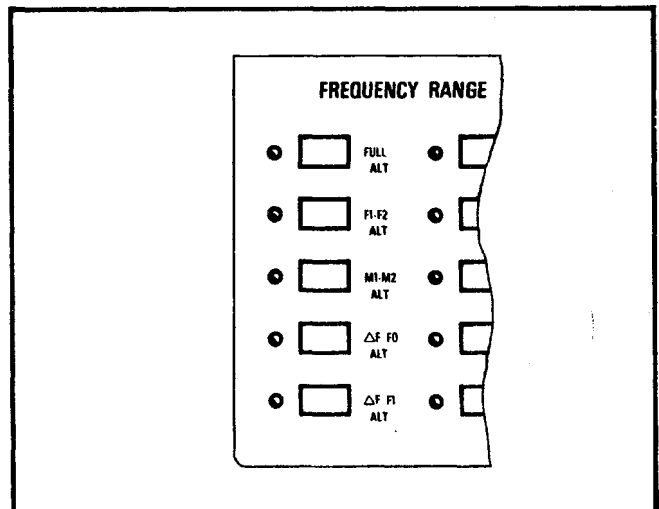

Figure 3-10. FULL, F1-F2, M1-M2, ΔF F0, ΔF F1 Pushbuttons

F1-F2: Selects a mode in which the frequency sweep is from F1 to F2. When F1-F2 is engaged, its indicator lights, the F1 frequency appears on the F1-F0-M1 LED readout, and the F2 frequency appears on the F2- Δ F-M2 LED readout.

M1-M2: Selects a mode in which the frequency sweep is from M1 to M2. When M1-M2 is engaged, its indicator lights, the M1 frequency appears on the F1-F0-M1 LED readout, and the M2 frequency appears on the F2- Δ F-M2 LED readout.

Δ F F0: Selects a mode in which the frequency sweep is symmetrical about the F0 frequency. The width of this sweep, though usually narrow-band, can go from 0 to 100% of the full frequency range. When Δ F F0 is engaged, its indicator lights, the F0 frequency appears on the F1-F0-M1 LED readout, and the Δ F Frequency appears on the F2- Δ F-M2 LED readout.

NOTE

The Δ F F0 and Δ F F1 sweeps can be asymmetrical. Asymmetry will occur when one-half the width of the Δ F sweep will cause the band-edge at either end of the frequency band to be exceeded. The sweep generator cannot sweep beyond its band-edges. (It will sweep only to the band-edge on one side of F0 (or F1) and up to one-half the Δ F sweep on the other side.)

Δ F F1: Selects a mode in which the frequency sweep is symmetrical about the F1 frequency. The width of this sweep and the frequency readouts are as described for Δ F F0, above.

The FULL, F1-F2, M1-M2, etc. controls are interlocked with the CW control group (subparagraph b, below) so that only one control can be engaged at any one time.

b. CW F0, CW F1, CW F2, CW M1, and CW M2 Pushbuttons (Figure 3-11).

These pushbuttons select a CW frequency mode, as follows:

CW F0: Selects a mode in which the CW frequency is at F0. When CW F0 is engaged, its indicator lights, and the F0 frequency appears on the F1-F0-M1 LED readout. The LED readout above F2- Δ F-M2 is blanked out.

CW F1: Selects a mode in which the CW frequency is at F1. When CW F1 is engaged, its indicator lights, and the F1 frequency appears on the F1-F0-M1 LED readout. The LED readout above F2- Δ F-M2 is blanked out.

CW F2: Selects a mode in which the CW frequency is at F2. When CW F2 is engaged, its indicator lights, and the F2 frequency appears on the F2- Δ F-M2 LED readout. The LED readout above F1-F0-M1 is blanked out.

CW M1: Selects a mode in which the CW frequency is at M1. When CW M1 is engaged, its indicator lights, and the M1 frequency appears on the F1-F0-M1 LED readout. The LED readout above F2- Δ F-M2 is blanked out.

CW M2: Selects a mode in which the CW frequency is at M2. When CW M2 is engaged, its indicator lights and the M2 frequency appears on the F2- Δ F-M2 LED readout. The LED readout above F1-F0-M1 is blanked out.

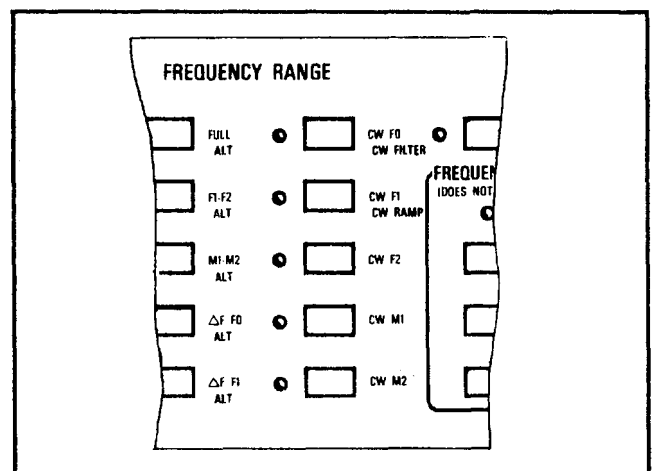

Figure 3-11. CW F0, CW F1, CW F2, CW M1/ and CW M2 Pushbuttons

- c. **FREQUENCY VERNIER Pushbuttons** (Figure 3-12). These pushbuttons may be used to make fine adjustments to (1) output frequency in the selected CW mode or (2) center frequency in the selected ΔF mode. The frequency resolution achievable using these pushbuttons is ± 100 kHz for all models except the 6642A, 6653A, and 6659A. For these three models, resolution is ± 200 kHz. Individual pushbuttons are described below.

INCREASE: Increases by a maximum of 12.7 MHz (25 MHz for Models 6642A, 6653A and 6659A) the value of selected CW output or ΔF center frequency. The LED readout value of the selected CW or ΔF frequency is not affected by this control.

DECREASE: Decreases by a maximum of 12.7 MHz (25 MHz for Models 6642A, 6653A and 6659A) the value of the selected CW output or ΔF center frequency. The LED readout value of the selected CW or ΔF frequency is not affected by this control.

OFF: Cancels the vernier correction being applied to the selected CW output or ΔF center frequency and turns the ACTIVE indicator OFF in that mode.

NOTE

A different vernier correction value can be entered for each of the five frequency parameters (F0, F1, F2, M1, M2). Once made, the vernier correction is stored in memory with the parameter and remains in effect even when the sweep generator has been turned off. Pressing the OFF pushbutton or changing the frequency value of a parameter cancels the vernier correction.

- d. **FM AND PHASELOCK Pushbutton** (Figure 3-13). This pushbutton allows the sweep generator output frequency to be either frequency-modulated or phase-locked to an external frequency standard. The external FM or phase-lock signal is input via

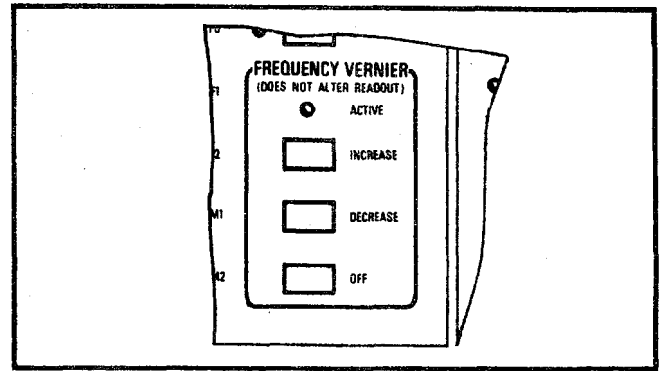

Figure 3-12. FREQUENCY VERNIER Controls

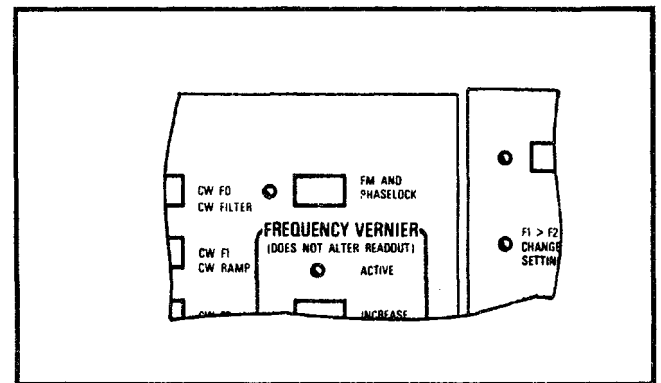

Figure 3-13. FM AND PHASELOCK Pushbutton

the rear panel EXT FM \emptyset LOCK INPUT connector.

3-2.3 TRIGGER Pushbuttons

The TRIGGER pushbuttons (Figure 3-14) select a trigger mode for the frequency sweep. These pushbuttons are interlocked so that only one may be selected at a time. A description of each pushbutton follows:

AUTO: Selects a mode in which the sweep recurs periodically with a minimum delay (hold-off) time between sweeps. RESET (default) state: On.

LINE: Selects a mode in which the sweep recurs at a multiple or submultiple of the line frequency.

EXT OR SINGLE: Selects a mode in which the sweep recurs only when internally or externally triggered. External

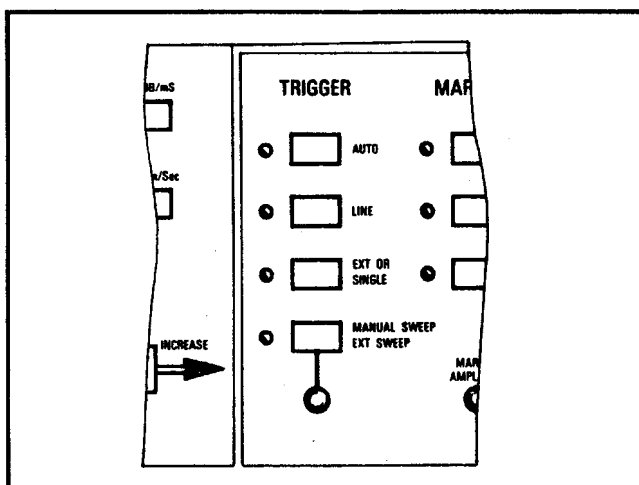

Figure 3-14. TRIGGER Pushbuttons

triggering is via the rear panel EXT TRIGGER INPUT connector; internal triggering is via this pushbutton. When the pushbutton is first pressed, the mode is selected. When the pushbutton is next pressed, the sweep is triggered. And, if the pushbutton is pressed again while the sweep is in progress, the sweep is aborted and reset.

MANUAL SWEEP: Selects a mode in which the frequency band is manually tuned. Manual tuning is provided by the associated control.

3-2.4 MARKERS Pushbuttons

There are three markers (M1, M2, F0) available with the sweep generator. Marker frequency is selected using the DATA ENTRY keypad (paragraph 3-2.1) or the RESET pushbutton (paragraph 3-2.7) – the keypad provides user selection, and the pushbutton provides preset selection. Marker type is selected using the MARKERS pushbuttons (Figure 3-15). The number of markers (1, 2, or 3) that occur when pressing a MARKERS pushbutton depends on which sweep mode has been selected: for FULL, F1-F2, and ΔF F1, all three markers occur; for ΔF F0, markers M1 and M2 occur; and for M1-M2, marker F0 occurs.

To determine which marker frequency (M1, M2, or F0) is being observed on a CRT display, press the M1, M2, and F0 pushbuttons

while observing the display. The marker will disappear from the display when the corresponding pushbutton is pressed.

The MARKERS pushbuttons are described below. These pushbuttons are interlocked in such a way that all three may be off, but only one may be on at a time.

VIDEO: Causes a positive-video pulse to occur at the marker frequency(ies). The amplitude of this pulse can be adjusted from 0 to +5 volts using the MARKER AMPLITUDE control. RESET (default) state: On.

RF: Causes a negative RF pip to occur at the marker frequency(ies). The amplitude of this pip can be adjusted between 0 and approximately 10 dB using the MARKER AMPLITUDE control.

INTENSITY: Causes an intensity dot to occur at the marker frequency(ies). The intensity marker is created by causing the sweep to dwell at the marker frequency(ies). No connection is required between the sweep generator and a CRT Z-axis input. The intensity of this marker is not affected by the MARKER AMPLITUDE control.

NOTE

For the intensity marker to be used with the Model 560/560A Scalar Network Analyzer, the network analyzer must be in the REAL TIME display mode.

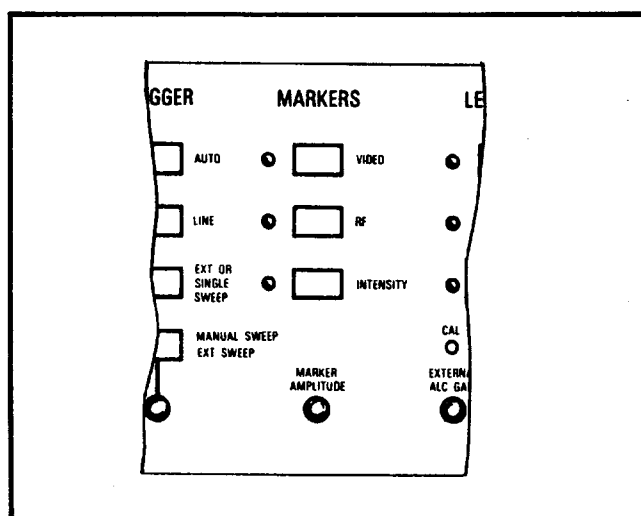

Figure 3-15. MARKERS Pushbuttons

3-2.5 LEVELING Controls

The LEVELING controls (Figure 3-16) select the type of leveling to be employed. These controls are interlocked so that all three pushbuttons may be off, but only one pushbutton may be on at a time. A description of each pushbutton follows.

INTERNAL: Selects an internally mounted directional detector for use in leveling the output power. When this pushbutton is engaged, the output power is sampled at the front-panel connector and fed back for leveling control. Internal leveling is not available for the 26.5-40 GHz band on the 6642A. RESET (default) state: On.

DETECTOR: Allows an external directional coupler and either a positive or a negative detector to be used in leveling the output power. When this pushbutton is engaged, the output power may be sampled at the end of the transmission line and fed back for leveling control.

POWER METER: Allows an external power meter, with either a positive or a negative recorder output voltage, to be used in leveling the output power. When this pushbutton is engaged, the output power may be sampled at the end of the transmission line and fed back for leveling control.

The sweep generator is compatible with power meters having a $\pm 1V$ FS analog output, such as the HP 431/432, HP 435/436, and PM 1009/1010 models.

EXTERNAL ALC GAIN: Adjusts the gain of the signal applied to the EXTERNAL INPUT connector. The control's calibrate function automatically indicates when the gain is adjusted correctly for optimum ALC operation. To use this function, push in and turn the control until the CAL indicator comes on and stays on continuously. The indicator goes out when the control is released to its normal position.

NOTE

The PUSH TO CAL function is not operative for the 26.5-40 GHz band on the 6642A.

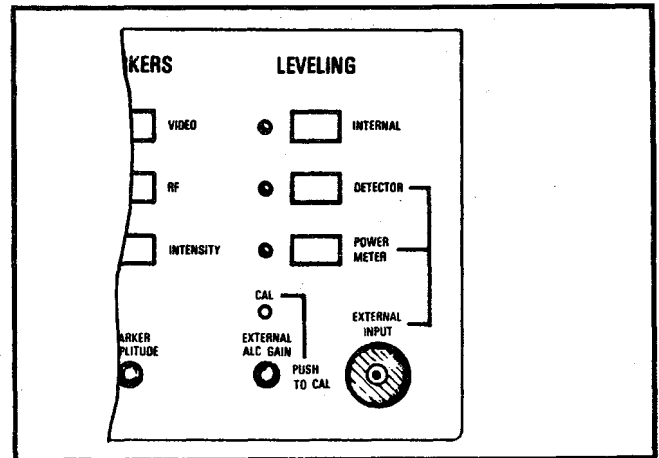

Figure 3-16. LEVELING Controls

3-2.6 RF OUTPUT Controls, Indicators, and Connector

The RF OUTPUT controls, indicators, and connector (Figure 3-17) are described below.

RF ON (Pushbutton): Turns the RF output on and off. RESET (default) state: On.

RETRACE RF (Pushbutton): Turns the RF output on and off during sweep retrace. This control is interlocked with the RF ON control so that it cannot be turned on unless the RF ON control is on, but it can be turned off independently of the RF ON control.

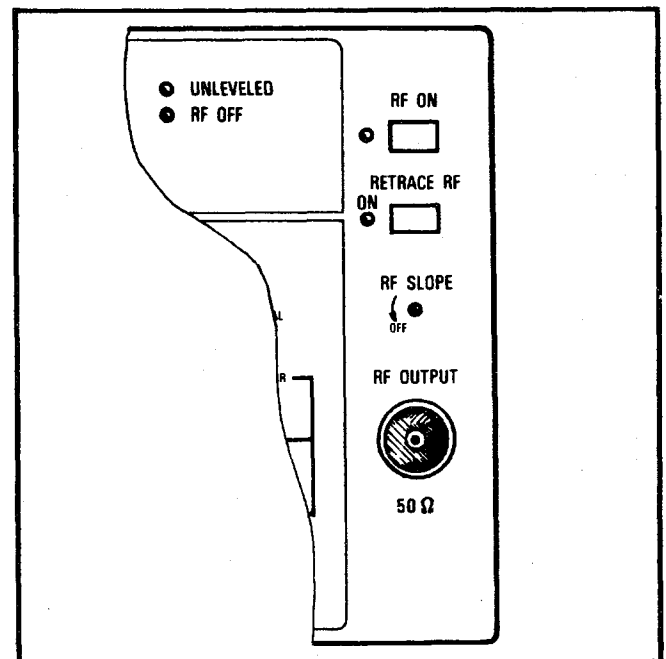

Figure 3-17. RF OUTPUT Controls

RF SLOPE (Control): Clockwise rotation adjusts the slope of the detected, leveled RF output signal. The control is used to compensate for the linear-with-frequency attenuation characteristics of RF transmission lines, when such lines are used with swept-frequency measurements. The OFF position provides optimum flatness at the RF OUTPUT connector.

UNLEVELED (Indicator): Lights when the RF output is unleveled.

RF OFF (Indicator): Flashes when the RF output is off.

RF OUTPUT (Connector): Provides RF output from 50Ω source. To prevent RF losses due to impedance mismatch, the mating connector and cable should have a 50Ω impedance rating.

3-2.7 POWER, SELF TEST, and RESET Controls

These controls (Figure 3-18) are described below.

POWER: Turns ac power on and off. When power is turned on, the A12 Microprocessor PCB software-version number (e.g. 1.7) appears on the F1-F0-M1 LED and a self test is initiated.

SELF TEST: Initiates self testing of sweep-generator circuits. Paragraph 3-4 describes the self-test feature.

RESET: Presets the front panel controls as shown below and numeric parameters as shown in Table 3-1.

Front Panel Controls

FREQUENCY RANGE: FULL (upper and lower frequency limits are displayed).

TRIGGER: AUTO

MARKERS: Off

LEVELING: INTERNAL

RF ON: On

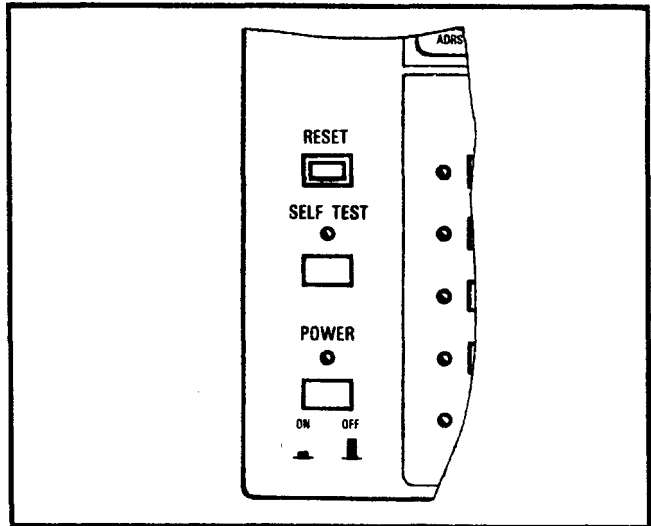

Figure 3-18. POWER, SELF TEST, and RESET Controls

3-2.8 BUS ADRS/RETURN TO LOCAL Control and GPIB Indicators

The BUS ADRS/RETURN TO LOCAL pushbutton and the REMOTE, LOCAL LOCKOUT, TALK, LISTEN, and SRQ GPIB indicators (Figure 3-19) are described below.

BUS ADRS/RETURN TO LOCAL (Pushbutton): In the local (front panel) mode, the pushbutton causes the bus address to be displayed on the SWEEP TIME-LEVEL LED readout. In the remote (GPIB) mode, provided that a local lockout bus message is not programmed, the pushbutton causes the sweep generator to return to the local mode.

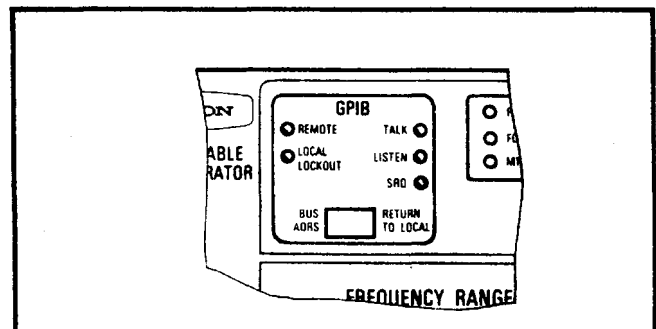

Figure 3-19. BUS ADRS/RETURN TO LOCAL Control and GPIB Indicators

Table 3-1. Reset (Default) Setting for Numeric Parameters

All Models: SWEEP TIME: 50 ms LEVEL: Maximum Leveled Power (Table 1-1) ΔF: 1000 Hz		
Model: 6609A F1: 10 MHz F2: 2000 MHz F0: 1000 MHz M1: 500 MHz M2: 1500 MHz	Model: 6629A-40 F1: 8000 MHz F2: 18000 MHz F0: 13000 MHz M1: 9000 MHz M2: 17000 MHz	Model: 6647A F1: 10 MHz F2: 18000 MHz F0: 10000 MHz M1: 1000 MHz M2: 17000 MHz
Model: 6617A F1: 10 MHz F2: 8000 MHz F0: 4000 MHz M1: 3000 MHz M2: 7000 MHz	Model: 6637A F1: 2000 MHz F2: 18000 MHz F0: 10000 MHz M1: 3000 MHz M2: 17000 MHz	Model: 6648A F1: 10 MHz F2: 20000 MHz F0: 10000 MHz M1: 3000 MHz M2: 19000 MHz
Model: 6621A F1: 2000 MHz F2: 12000 MHz F0: 9000 MHz M1: 3000 MHz M2: 11000 MHz	Model: 6637A-40 F1: 2000 MHz F2: 18000 MHz F0: 10000 MHz M1: 3000 MHz M2: 17000 MHz	Model: 6653A F1: 2000 MHz F2: 26000 MHz F0: 14000 MHz M1: 3000 MHz M2: 25000 MHz
Model: 6621A-40 F1: 2000 MHz F2: 12000 MHz F0: 9000 MHz M1: 3000 MHz M2: 11000 MHz	Model: 6638A F1: 2000 MHz F2: 20000 MHz F0: 11000 MHz M1: 3000 MHz M2: 19000 MHz	Model: 6659A F1: 10 MHz F2: 26000 MHz F0: 14000 MHz M1: 3000 MHz M2: 25000 MHz
Model: 6629A F1: 8000 MHz F2: 18000 MHz F0: 13000 MHz M1: 9000 MHz M2: 17000 MHz	Model: 6642A F1: 18000 MHz F2: 40000 MHz F0: 25000 MHz M1: 19000 MHz M2: 39000 MHz	

REMOTE (Indicator): Lights when sweep generator goes under GPIB control. Remains lit until sweep generator is returned to local control.

LOCAL LOCKOUT (Indicator): Lights when sweep generator receives a local lockout message; remains lit until local lockout message is rescinded. When LOCAL LOCKOUT indicator is lit, sweep generator cannot be returned to local control via the front panel.

TALK (Indicator): Lights when sweep generator is addressed to talk; remains lit until unaddressed.

LISTEN (Indicator): Lights when sweep generator is addressed to listen; remains lit until unaddressed.

SRQ (Indicator): Lights when sweep generator sends a Service Request; remains lit until

a serial poll is received or the SRQ function is reset (paragraph 3-7.4).

3-3 REAR PANEL CONTROLS AND CONNECTORS

The rear panel controls and connectors are described in Figure 3-20.

3-4 SELF-TEST FEATURES

The sweep generator is equipped with a self-test feature that uses an internal microprocessor to test (1) selected circuits on each of the printed circuit boards and (2) all of the indicators and LED displays on the front panel. There are three ways in which a self-test is initiated. And, if an error is detected, there are up to 25 error codes that may be displayed on the front panel. The three ways in which a self test is initiated are described in Table 3-2; the error codes are described in Table 3-3.

Table 3-2. Three Ways in Which Self-Test is Initiated

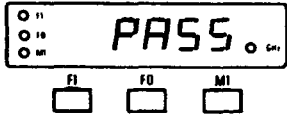
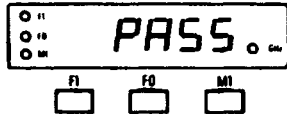
How Self Test Is Initiated	Indication If Self Test Passes	Indication If Self Test Fails
1. Pressing POWER pushbutton to ON.		An error code number between 00 and 24 is displayed above the F2-ΔF-M2 group of pushbuttons (Table 3-3).
2. Pressing SELF TEST.	a. All front panel indicators and LED displays are tested. (Indicators and displays light and remain lit 5 seconds.)	Same as above.
and		
3. Sending sweep generator TST command over the bus (Option 3).	b. 	a. Numeric LED readouts are blanked. b. The ASCII character "F" is sent over the bus to the controller.

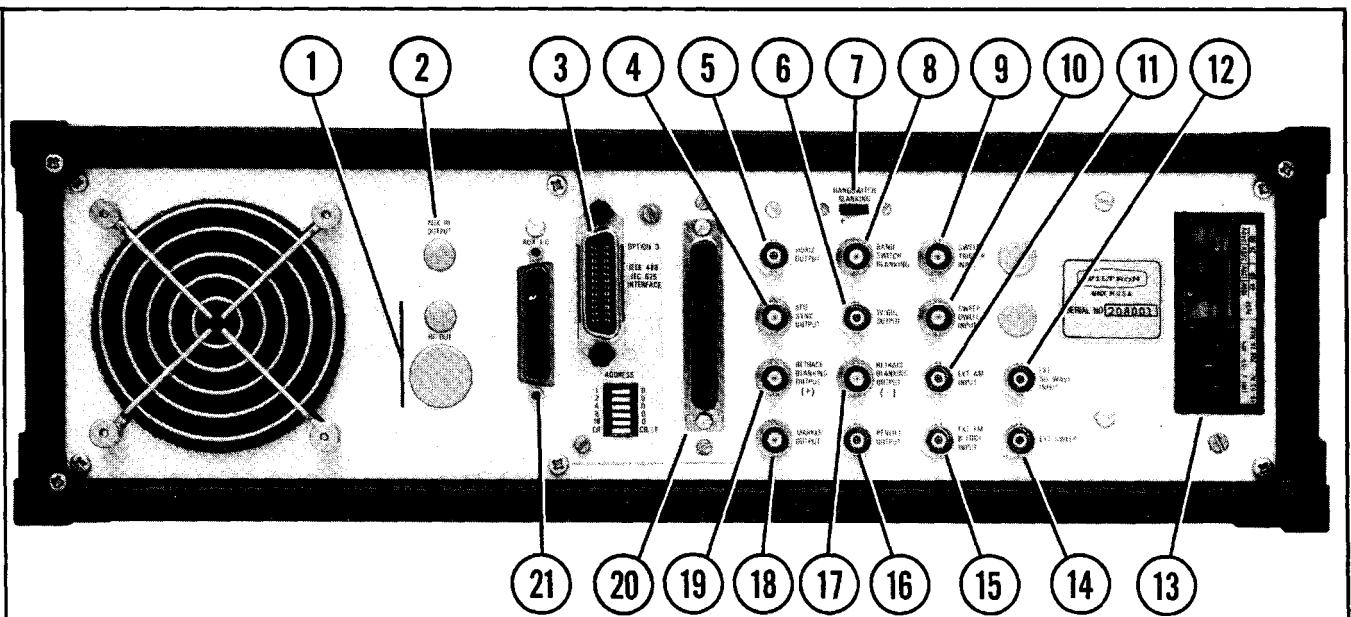

- ① **Main RF OUTPUT Connector (Option 9):** Provides 50-ohm RF output. (Not available on 6642A above 26.5 GHz.)
- ② **Auxiliary RF OUTPUT Connector (Option 10):** Provides 50-ohm RF output. Output power is attenuated by ≈ 25 dB from the power available at the main RF OUTPUT connector.
- ③ **IEEE-488 Interface Bus Connector (Option 3):** Provides input output connections to General Purpose Interface Bus (GPIB).
- ④ **SEQ SYNC OUTPUT:** Provides a positive pulse during sweep retrace, and when the RF plug-in switches between different YIG oscillators (band-switches). Signal is used to supply retrace information to the WILTRON Model 560/560A and HP Model 8410 Network Analyzers. Connects to FROM SEQ SYNC WILTRON connector on Model 560 or to Z-AXIS SELECT on Model 560A.
- ⑤ **HORIZ OUTPUT:** Provides 0 to 10 volts during all sweep modes, and during all CW modes when CW RAMP is activated. Connects to HORIZ INPUT (HORIZONTAL INPUT on 560A) connector on Model 560 Scalar Network Analyzer.
- ⑥ **1V/GHz OUTPUT:** Provides voltage signal equal to 1V per GHz for all models except the 6642A, 6653A, and 6659A. For these three models, the signal is 0.5V per GHz. Signal may be used as an approximate frequency reference and also for tuning the HP 8410B Network Analyzer.
- ⑦ **BANDSWITCH BLANKING (+, -):** Switches BANDSWITCH BLANKING signal either plus or minus.
- ⑧ **BANDSWITCH BLANKING:** Provides + or -5V pulse, depending on BANDSWITCH BLANKING switch, during RF oscillator bandswitching. ± 5 V pulse may be used to blank sweep generator bandswitch points on oscilloscope display.

Figure 3-20. Rear Panel Controls and Connectors

- ⑨ **SWEEP TRIGGER INPUT:** Provides for external sweep triggering when TRIGGER-EXT OR SINGLE pushbutton is engaged. Trigger occurs on closure-to-ground. To provide for proper triggering, the input pulse should be a clock pulse with the following characteristics:
- | | |
|-------------------------|-----------------------|
| Amplitude: 4 to 25 Vpk | Fall Time: <5 μ s |
| Pulse Width: >1 μ s | Polarity: Low true |
- ⑩ **SWEEP DWELL INPUT:** Allows a pulse from the HP 8410 Network Analyzer to cause the sweep generator sweep to dwell during 8410 sweep retrace.
- ⑪ **EXT AM INPUT:** Provides for applying amplitude modulation to the RF output signal. The frequency of the modulating signal can go from dc to 50 kHz. Input impedance is 10 kilohms.
- ⑫ **EXT SQ WAVE INPUT:** Provides for applying square-wave modulation to the RF output signal. The input square wave can have a frequency of up to 50 kHz and an amplitude of ± 10 volts. Input impedance is TTL compatible. (Not available on 6642A.)
- ⑬ **Voltage Selector Module:** Allows 100, 115-120, 220, or 230-240 Vac line voltage values to be used with sweep generator. Refer to paragraph 2-3 for setup instructions.
- ⑭ **EXT SWEEP:** Allows an external 0 to 10 volt ramp to be used to sweep the output frequency. To use this input, the EXT SWEEP pushbutton must be activated.
- ⑮ **EXT FM \emptyset LOCK INPUT:** Provides for applying frequency modulation and phase-lock control (paragraph 3-2.2d) to the RF output signal.
- ⑯ **PENLIFT OUTPUT:** Provides isolated, normally-open relay contacts for lifting recorder pen during sweep retrace. Can be modified internally for normally-closed relay contact operation.
- ⑰ **RETRACE BLANKING OUTPUT (-):** Provides -5V pulse during sweep retrace.
- ⑱ **MARKER OUTPUT:** Provides video marker output when MARKERS-VIDEO pushbutton is engaged. Connects to MARKER INPUT connector on Model 560/560A Scalar Network Analyzer.
- ⑲ **RETRACE BLANKING OUTPUT (+):** Provides +5V pulse during sweep retrace. Connects to FROM BLANKING (+) WILTRON connector on WILTRON Model 560/560A Scalar Network Analyzer.
- ⑳ **DATA I/O (Option 14):** 37-pin connector providing interface between the Model 661 Tracking Sweeper Controller and the GPIB. Connects with DATA I/O port on 661. See Figure 3-21 for a pinout diagram.
- ㉑ **AUX I/O:** 25-pin connector providing interface between the sweep generator and the Model 661 Tracking Sweeper Controller or Model 560A Scalar Network Analyzer. See Figure 3-22 for a pinout diagram.

Figure 3-20. Rear Panel Controls and Connectors (Continued)

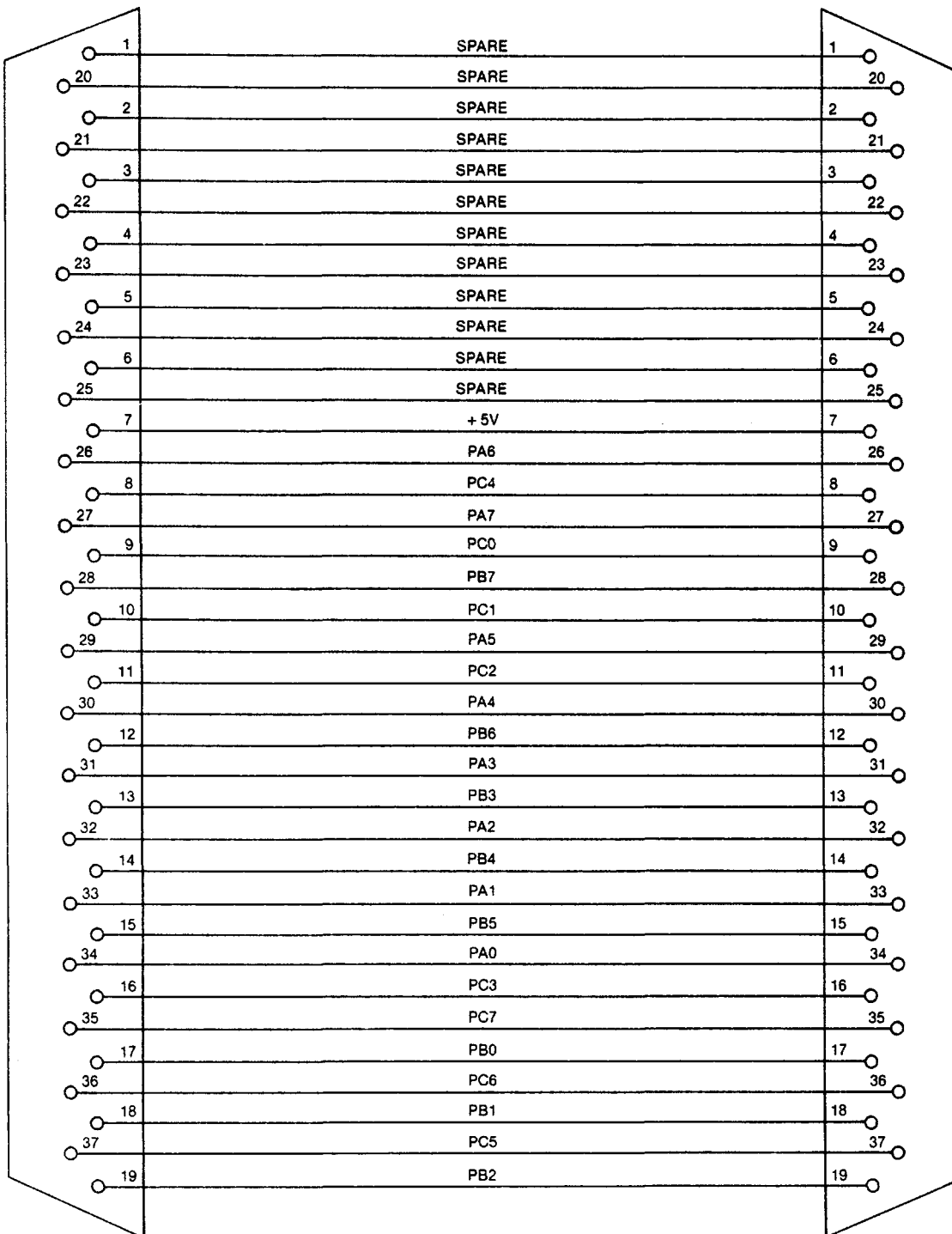

MNEMONICS
 PA, PB, PC refer to IC A1U1 ports A, B, & C.
 Digits refer to bit numbers.

Figure 3-21. Pinout Diagram, DATA I/O Interconnect Cable

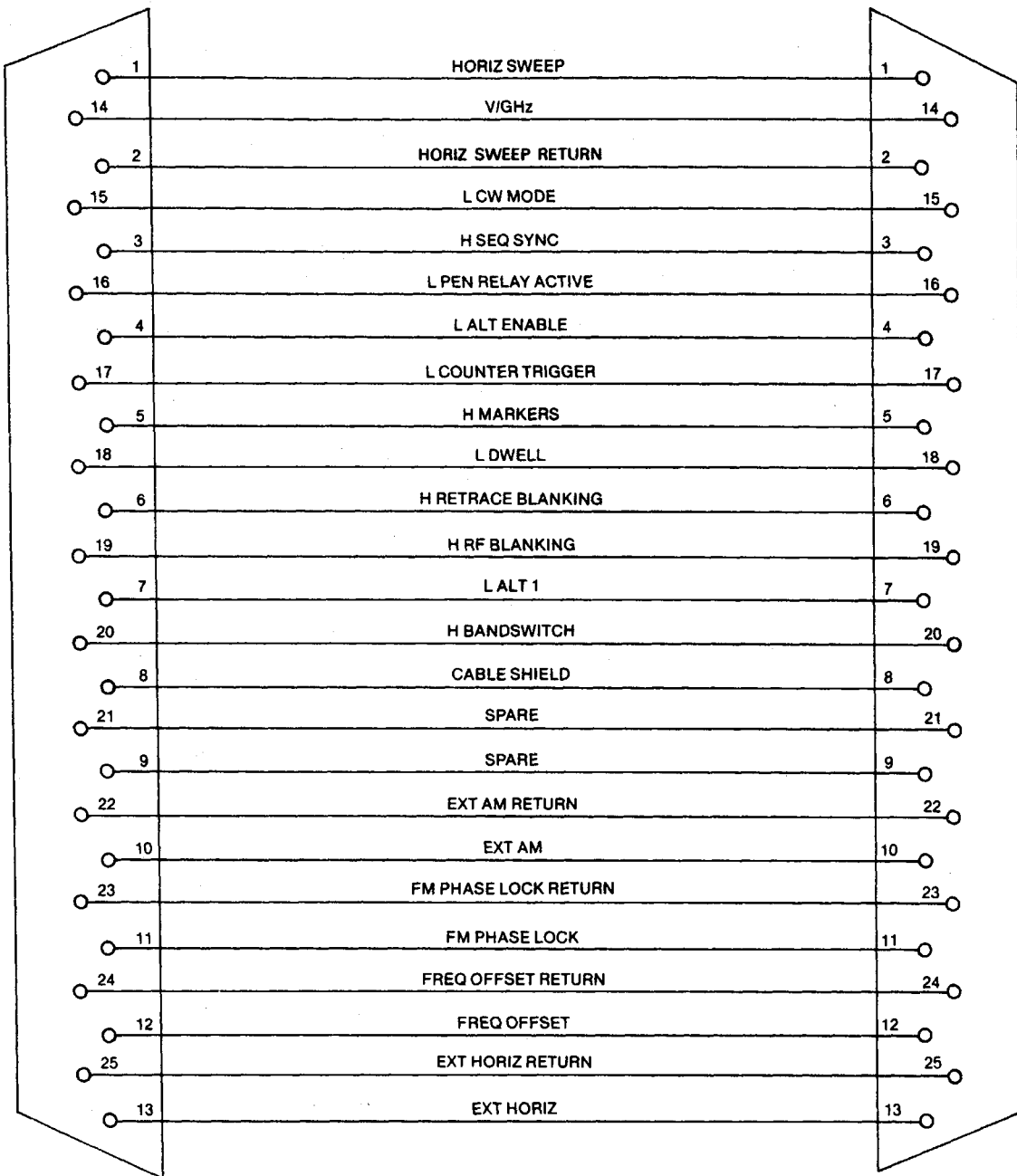
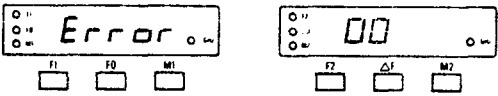
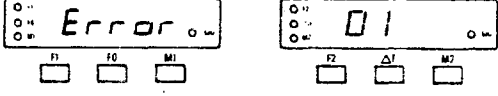
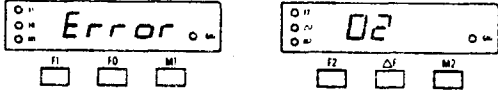
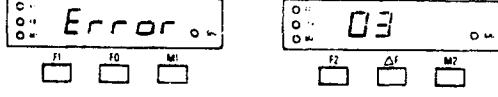
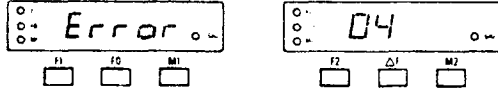
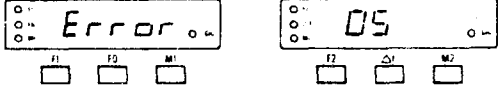
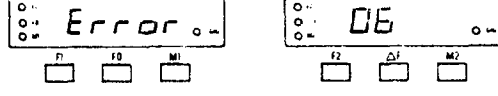
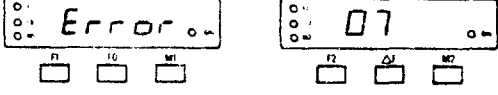
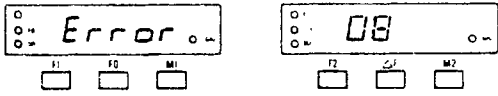
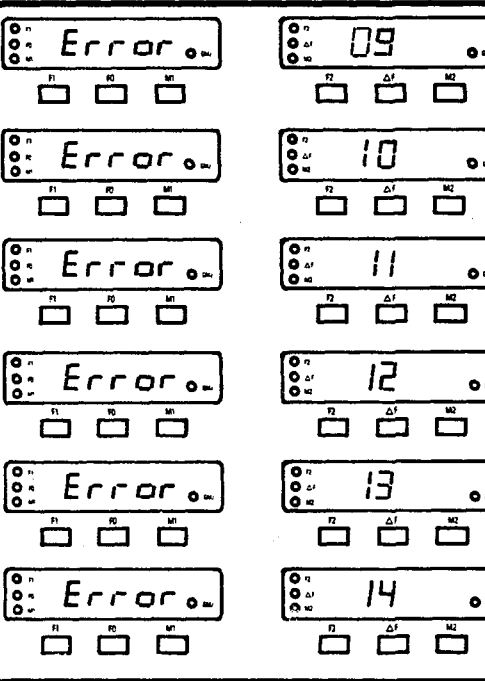
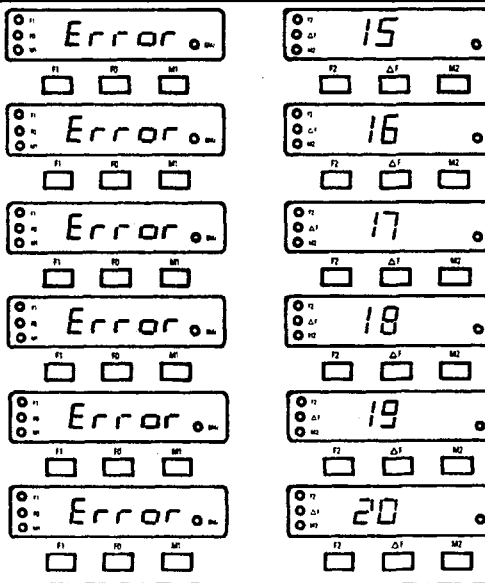
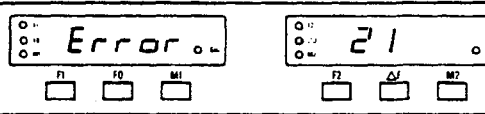
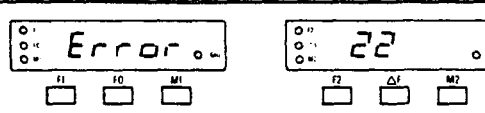
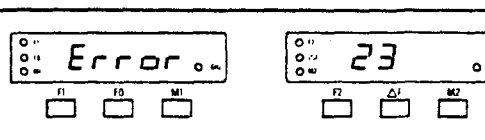

Figure 3-22. Pinout Diagram, AUX I/O Interconnect Cable

Table 3-3. Self-Test Error Codes

GENERAL: The microprocessor's self-test routines reside in software modules; each module is assigned an error-code number. When a self-test is initiated, these software modules are called up in sequential order, beginning with number 00 and ending with number 24. If an error is detected, the error-code number is displayed and the self-test continues. If multiple errors are detected, each error-code number is displayed. To abort self-test once it has begun, press the RESET pushbutton.

SWEEP GENERATOR ERROR DISPLAY	MEANING OF ERROR CODE	RECOMMENDED ACTION
	<p>A voltage supply other than the 5V supply is out of tolerance. If the 5V supply is faulty, the sweep generator will not operate.</p>	<p>See Figure 7-127 for troubleshooting flow-chart.</p>
	<p>Line voltage too low.</p>	<p>See Figure 7-128 for troubleshooting flow-chart.</p>
	<p>Line voltage too high.</p>	<p>See Figure 7-129 for troubleshooting flow-chart.</p>
	<p>ROM U5 fails bit parity check.</p>	<p>Replace A12 U5.</p>
	<p>ROM U6 fails bit parity check.</p>	<p>Replace A12 U6.</p>
	<p>ROM U7 fails bit parity check.</p>	<p>Replace A12 U7.</p>
	<p>ROM U8 fails bit parity check.</p>	<p>Replace A12 U8.</p>
	<p>ROM U9 fails bit parity check.</p>	<p>Replace A12 U9.</p>
	<p>One or more RAMs, U11, U12, U37, U38, fail write verification test.</p>	<p>Replace RAMs.</p>

SWEEP GENERATOR ERROR DISPLAY	MEANING OF ERROR CODE	RECOMMENDED ACTION																										
	<p>The association of error codes, PCBs, and frequency bands is shown below:</p> <table border="1"> <thead> <tr> <th>Error Code</th> <th>PCB (Band)</th> </tr> </thead> <tbody> <tr> <td>09</td> <td>A6 (Het.)</td> </tr> <tr> <td>10</td> <td>A6 (Osc. 1)</td> </tr> <tr> <td>11</td> <td>A7 (Osc. 2)</td> </tr> <tr> <td>12</td> <td>A8 (Osc. 3)</td> </tr> <tr> <td>13</td> <td>A9 (Osc. 4)</td> </tr> </tbody> </table>	Error Code	PCB (Band)	09	A6 (Het.)	10	A6 (Osc. 1)	11	A7 (Osc. 2)	12	A8 (Osc. 3)	13	A9 (Osc. 4)	<p>Troubleshooting flowcharts are given below:</p> <table border="1"> <thead> <tr> <th>Error Code</th> <th>Flowchart</th> </tr> </thead> <tbody> <tr> <td>09</td> <td>Figure 7-85</td> </tr> <tr> <td>10</td> <td>Figure 7-86</td> </tr> <tr> <td>11</td> <td>Figure 7-87</td> </tr> <tr> <td>12</td> <td>Figure 7-87</td> </tr> <tr> <td>13</td> <td>Figure 7-87</td> </tr> <tr> <td>14</td> <td>Figure 7-88</td> </tr> </tbody> </table>	Error Code	Flowchart	09	Figure 7-85	10	Figure 7-86	11	Figure 7-87	12	Figure 7-87	13	Figure 7-87	14	Figure 7-88
Error Code	PCB (Band)																											
09	A6 (Het.)																											
10	A6 (Osc. 1)																											
11	A7 (Osc. 2)																											
12	A8 (Osc. 3)																											
13	A9 (Osc. 4)																											
Error Code	Flowchart																											
09	Figure 7-85																											
10	Figure 7-86																											
11	Figure 7-87																											
12	Figure 7-87																											
13	Figure 7-87																											
14	Figure 7-88																											
	<p>The association of error codes and frequency bands is shown below:</p> <table border="1"> <thead> <tr> <th>Error Code</th> <th>Freq. Band</th> </tr> </thead> <tbody> <tr> <td>15</td> <td>Het.</td> </tr> <tr> <td>16</td> <td>Osc. 1</td> </tr> <tr> <td>17</td> <td>Osc. 2</td> </tr> <tr> <td>18</td> <td>Osc. 3</td> </tr> <tr> <td>19</td> <td>Osc. 4</td> </tr> <tr> <td>20</td> <td>All</td> </tr> </tbody> </table>	Error Code	Freq. Band	15	Het.	16	Osc. 1	17	Osc. 2	18	Osc. 3	19	Osc. 4	20	All	<p>See Figure 7-46 for troubleshooting flowcharts.</p>												
Error Code	Freq. Band																											
15	Het.																											
16	Osc. 1																											
17	Osc. 2																											
18	Osc. 3																											
19	Osc. 4																											
20	All																											
	<p>Analog circuit error, detected during Ramp Generator (A2) PCB test.</p>	<p>See Figure 7-35 for troubleshooting flowchart.</p>																										
	<p>Analog circuit error, detected during Marker (A3) PCB test.</p>	<p>See Figure 7-40 for troubleshooting flowchart.</p>																										
	<p>Analog circuit error, detected during FM Attenuator (A10) PCB test.</p>	<p>See Figure 7-92 for troubleshooting flowchart.</p>																										

SWEEP GENERATOR ERROR DISPLAY	MEANING OF ERROR CODE	RECOMMENDED ACTION
	<p>Only appears if Option 3 installed. Indicates error detected during GPIB Interface (A1) PCB test.</p>	<p>See Figure 7-28 for troubleshooting flow-chart.</p>

Table 3-4. Recommended Test Equipment for Operational Checkout

EQUIPMENT	REQUIRED CHARACTERISTICS	RECOMMENDED MANUFACTURER	PURPOSE
Scalar Network Analyzer	Ability to display frequency response of sweep generator.	WILTRON Model 560 Scalar Network Analyzer, with 7N50 Detector or 7S50, Option 2 Detector (6642A)	Display sweep generator output during operational checkout.
Microwave Frequency Counter	.01 to 26.5 GHz frequency response with source locking capability.	EIP Model 578	Used with Table 3-6 to check the operation of the FREQUENCY VERNIER controls and phase-locking capability for all models except 6642A.
Microwave Frequency Counter	26.5 to 40 GHz frequency response with source-locking capability.	EIP Model 578/06 with 590 frequency extension kit and Option 91 Remote Sensor	Used with Table 3-6 to check the operation of the 6642A FREQUENCY VERNIER controls and phase-locking capability.
Directional Coupler	Ability to couple signals within a portion of the 10 MHz to 18 GHz frequency range.	NARDA Model 3202B-10	
RF Detector	Ability to detect signals within the 10 MHz to 18 GHz frequency range.	WILTRON Model 75N50	Used with Table 3-7 to check the operation of external leveling feature.
Power Meter	Ability to provide output signal that is (1) proportional to the measured power and (2) 1 volt for full-scale deflection.	Hewlett-Packard Model 435A with 8481 Power Sensor	
Crystal Detector	26.5 to 40 GHz frequency range	HP R422A	
Power Meter		HP 432A, with R486A Thermistor Mount	Used with Table 3-8 to check the operation of the 6642A external leveling feature.
Adapter Cable for 560	Adapt 560 input to waveguide detector.	WILTRON 560-10BX-1	
Connector Adapters (2)	Adapt between SMA-female and BNC-male connectors.	Pomona Elect. 4290	

3-5 OPERATIONAL CHECKOUT PROCEDURES

The operational checkout procedures for the sweep generator are given in paragraphs 3-5.1, 3-5.2, 3-5.3 and 3-5.4. These procedures are organized by function, so that only those functions being used need to be checked.

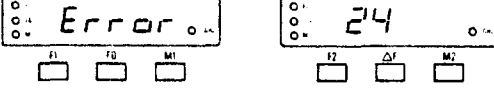
Table 3-4 (facing page) gives the recommended test equipment for the four operational checkout procedures (Tables 3-5, 3-6, 3-7, 3-8.)

Notice that the test equipment differs for each checkout procedure. If the recommended test equipment is not available, equipment with equivalent characteristics may be substituted.

3-5.1 Operational Checkout, Sweep Generator Confidence Test

This paragraph provides the confidence test procedure for the sweep generator. Figure 3-23 shows the test setup and Table 3-5 gives the test procedure.

Table 3-5. Sweep Generator Confidence Test (All models except 6642A)

1. Connect the equipment as shown in Figure 3-23.
2. Turn on the sweep generator and press RESET. If no error code appears on the appropriate LED readouts (Table 3-3), the sweep generator should be functioning normally.

NOTE

The digits on the LED displays will be random for the first 1/2-second after turn-on.

3. Observe the 560 CRT. A leveled trace should be located near center screen.
4. Press LEVELING INTERNAL. The 560 trace should go unleveled.
5. Press INTERNAL again. A leveled trace returns to the 560 CRT.
6. Press LEVEL and set for 0 dBm (+3 dBm, 6609A; -5 dBm, 6642A). Verify that the 560 trace "jumps" 2 divisions (10 dB), and that the trace remains level.

END OF CONFIDENCE TEST

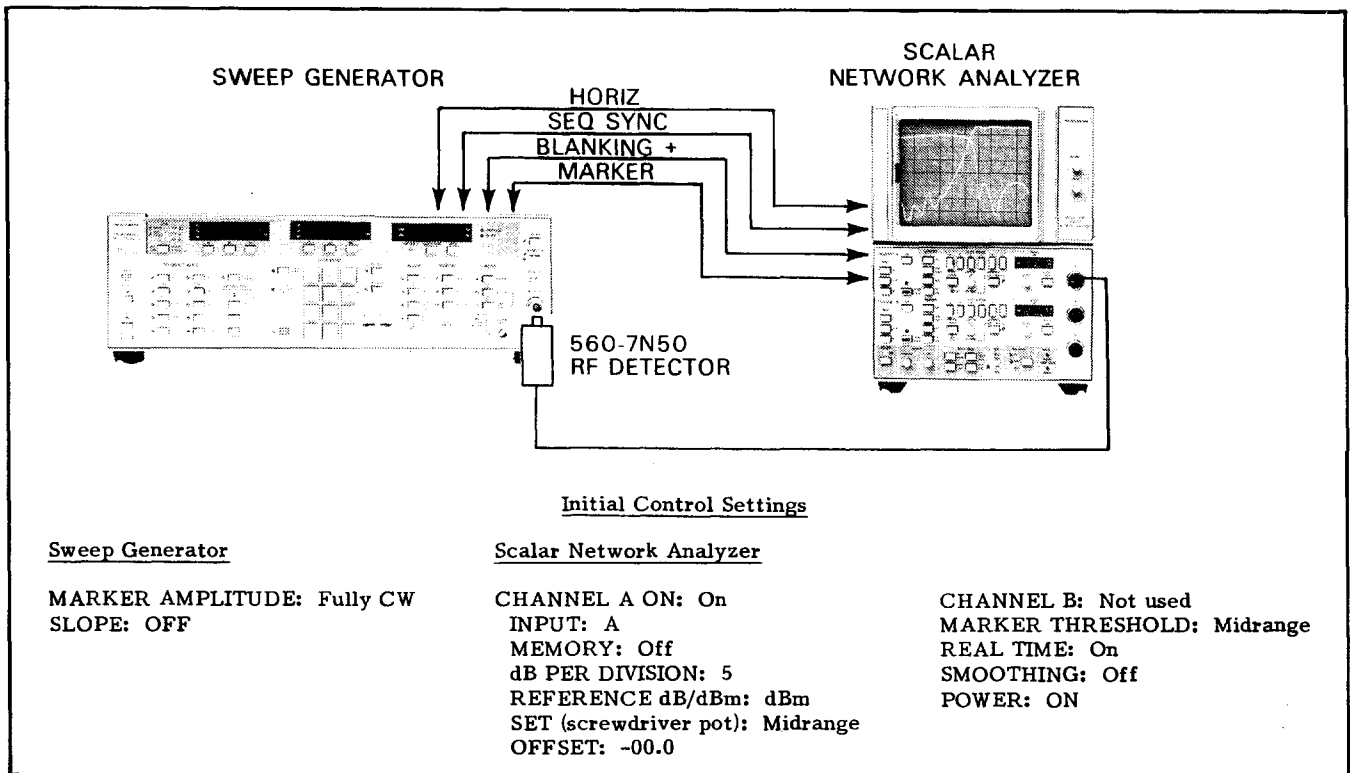

Figure 3-23. Equipment Setup for Confidence Test (except 6642A)

3-5.2 Operational Checkout Procedure, FREQUENCY VERNIER Pushbuttons and Phase-Lock Operation

The FREQUENCY VERNIER pushbuttons provide for making small changes to the output frequency in the CW F0 thru CW M2, ΔF F0, and ΔF F1 operational modes. These frequency changes do not affect the readout that appears on the respective frequency's front panel LED display.

The phase-lock operation automatically "locks" the sweep generator's output frequen-

cy to the crystal-controlled time-base of the frequency counter. When the EIP 578 Source Locking Counter is used, the phase-lock function allows the sweep generator's frequency to be accurately resolved to 100 kHz for all models except the 6642A, 6653A and 6659A. For these 3 models, resolution is ± 200 kHz.

The test setup for operationally checking the FREQUENCY VERNIER controls and phase-lock operation for all models except 6642A is shown in Figure 3-24; the test setup for the 6642A is shown in Figure 3-25; the checkout procedure is given in Table 3-6.

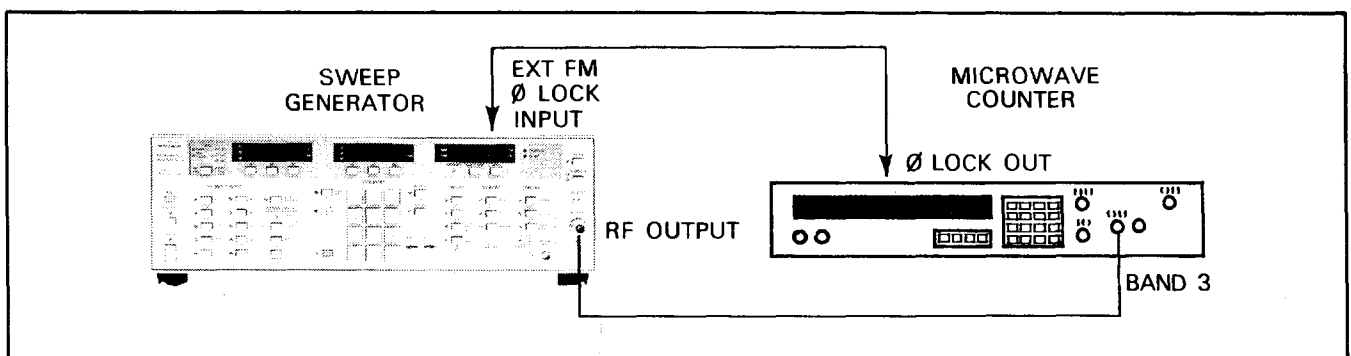

Figure 3-24. Test Setup for Operational Checkout of FREQUENCY VERNIER Controls (All models except 6642A)

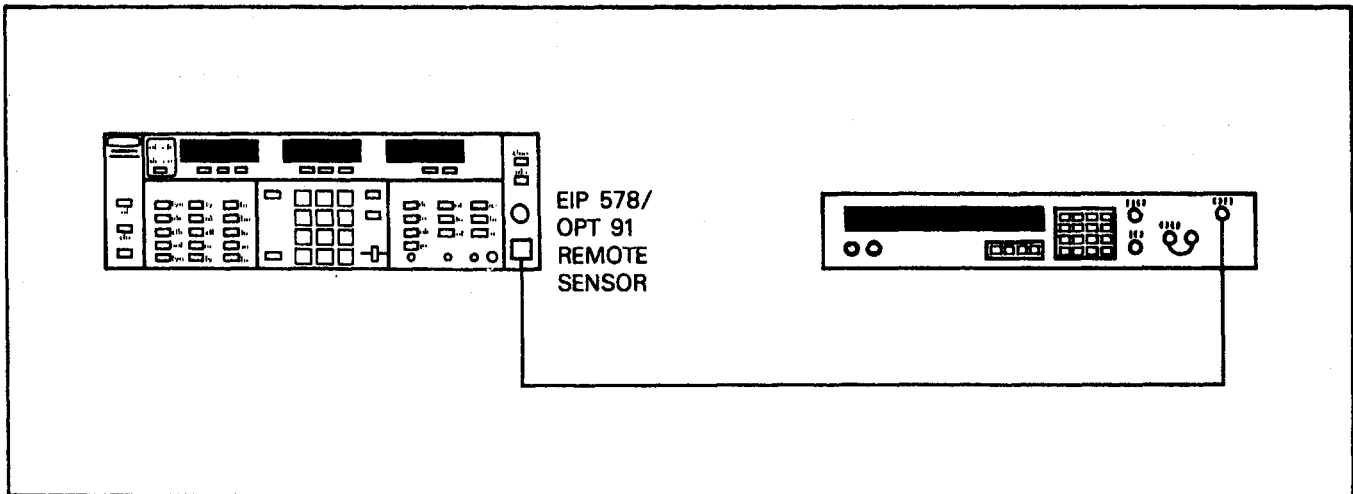

Figure 3-25. Test Equipment Setup for Operational Checkout of FREQUENCY VERNIER Controls on Model 6642A, 26.5-40 GHz Band

Table 3-6. Operational Checkout Procedure, FREQUENCY VERNIER Controls and Phase-Lock Operation (all models)

1. Connect test equipment as shown in Figure 3-24 or 3-25.
2. Turn on power to sweep generator (sweeper) and frequency counter (counter).
3. On sweeper, press LEVEL and set for 0 dBm.
4. Connect 50 Ω cable between RF OUTPUT on sweeper and the appropriate BAND input on counter.

Frequency Vernier Controls Operation

5. On sweeper, press CW F0 and set for low-end frequency +50 MHz.
6. Observe counter:
 - a. If frequency is below the sweeper-output frequency, press & hold FREQUENCY VERNIER INCREASE until counter frequency equals sweeper frequency.
 - b. If frequency is above the sweeper-output frequency, press & hold FREQUENCY VERNIER DECREASE until counter frequency equals sweeper frequency.
7. On sweeper, press CW F2 and set for midband frequency.
8. Repeat step 6 above.
9. On sweeper, press CW M2 and set for high-end frequency -50 MHz.
10. Repeat step 6 above.

Table 3-6. Operational Checkout Procedure, FREQUENCY VERNIER Controls and Phase-Lock Operation (all models) (Continued)

11. Verify that the FREQUENCY VERNIER ACTIVE indicator is lit for each of the parameters receiving a frequency correction, as follows:
 - a. Press CW F0 and verify that ACTIVE indicator is lit.
 - b. Press CW F1 and verify that ACTIVE indicator is not lit.
 - c. Press CW F2 and verify that ACTIVE indicator is lit.
 - d. Press CW M1 and verify that ACTIVE indicator is not lit.
 - e. Press CW M2 and verify that ACTIVE indicator is lit.
 - f. Press ΔF F0 and verify that ACTIVE indicator is lit.
 - g. Press ΔF F1 and verify that ACTIVE indicator is not lit.
12. Verify that frequency-vernier correction is canceled when the parameter to which a vernier correction was applied is changed, as follows:
 - a. Press CW F0 and set for midband frequency.
 - b. Verify that the FREQUENCY VERNIER ACTIVE indicator went out.

Phase-Lock Operation

13. Connect a BNC-to-BNC test cable between \emptyset LOCK OUT on counter and EXT FM \emptyset LOCK INPUT on sweeper.
14. On counter, enter a lock frequency within the sweeper's range (use keypad and enter this frequency on the auxiliary (small) display).
15. On sweeper,
 - a. Press CW F1 and set for the "lock" frequency.
 - b. Press FM AND PHASELOCK.
16. On counter, press LOCK.
17. Observe counter; it should indicate the lock frequency ± 1 count.

**3-5.3 Operational Checkout Procedure,
External Leveling Function (All
Models Except 6642A)**

External leveling of the RF source is pro-

vided by the front panel EXTERNAL INPUT connector and the LEVELING-DETECTOR or -POWER METER pushbutton. A test setup for external leveling is shown in Figure 3-26; the operational checkout procedure is given in Table 3-7.

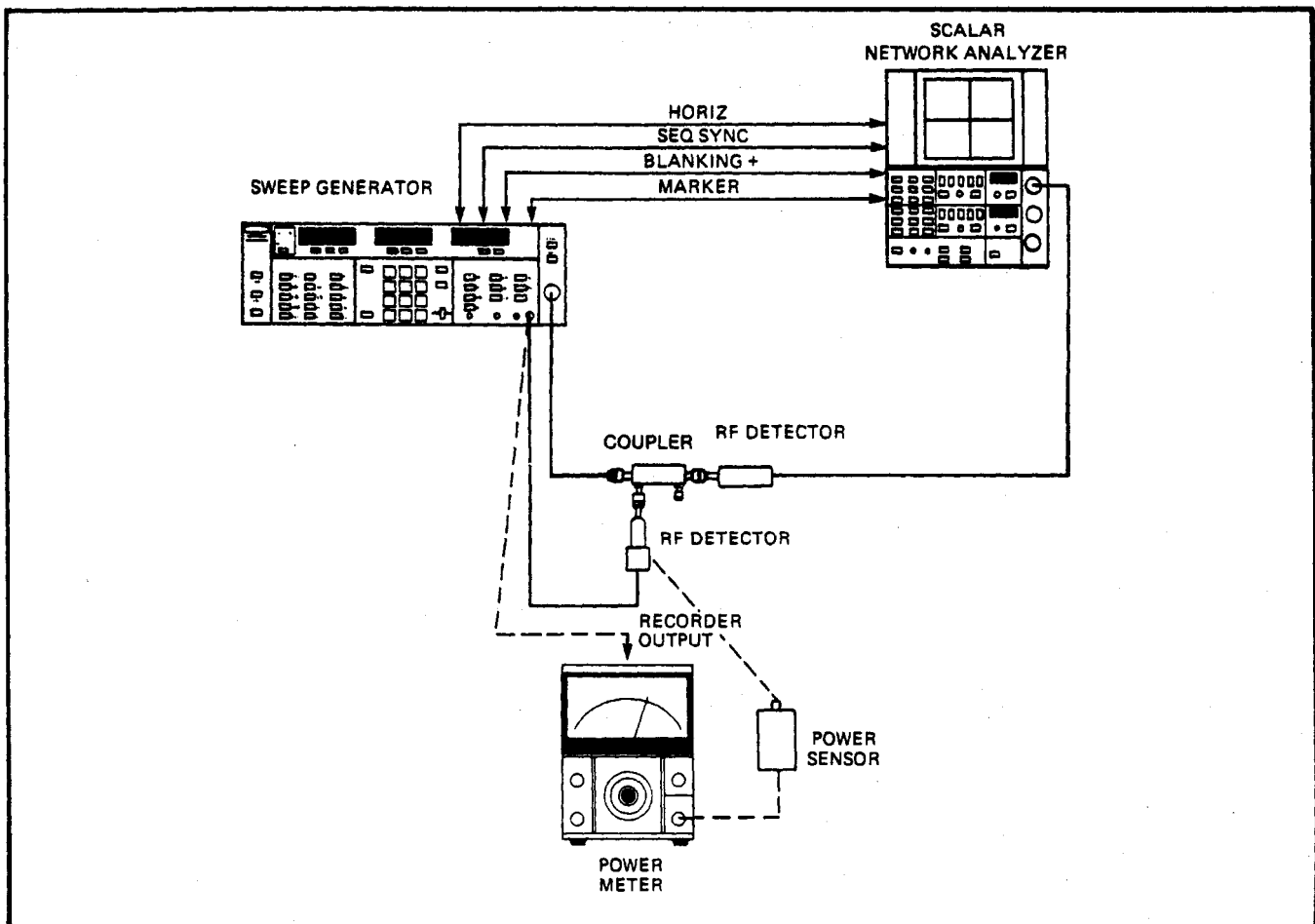

Figure 3-26. Test Setup for External Leveling (except 6642A)

Table 3-7. Operational Checkout Procedure, LEVELING-DETECTOR and -POWER METER Controls (except 6642A)

1. Connect test equipment for detector leveling, as shown by the solid lines in Figure 3-26.
2. Turn on power on sweep generator (sweeper) and scalar network analyzer (network analyzer).
3. On sweeper,
 - a. Press FREQUENCY RANGE - F1-F2.
 - b. Set F1 and F2 parameters for a sweep range compatible with the directional coupler being used. For example:
 - Push F1 and set for 1 GHz.
 - Push F2 and set for 12.4 GHz.

The above two settings are compatible with the NARDA 3202B-10.
 - c. Press LEVEL and set for 0 dBm.

Table 3-7. Operational Checkout Procedure, LEVELING-DETECTOR
and -POWER METER Controls (Continued)

- d. Press SWEEP TIME and set for 50 ms.
- e. Press TRIGGER – AUTO.
- f. Press LEVELING – INTERNAL.
4. On network analyzer,
 - a. Position front panel controls as follows:

CHANNEL A ON: On
INPUT: A
MEMORY: Off
REFERENCE dB/dBm: dBm
OFFSET: 00.0
dB PER DIVISION: 1
 - b. Press Channel A REF POS LOCATE and adjust SET control to position trace on center graticule line.
 - c. Release REF POS LOCATE and observe that a leveled trace slightly below the 0 dBm reference line appears on the CRT.
5. On sweeper,
 - a. Press LEVELING – DETECTOR.
 - b. Push in on EXTERNAL ALC GAIN control and turn until CAL indicator comes on and stays on.
 - c. Release EXTERNAL ALC GAIN.
6. Observe that a leveled trace is present on CRT.
7. Observe that the UNLEVELED indicator on the sweeper is not lit.
8. On sweeper, press LEVELING – DETECTOR to off. Observe that the CRT trace becomes unlevelled and the sweeper UNLEVELED indicator lights.
9. Disconnect the RF detector from between the sweeper and the directional coupler; in its place, connect the power meter as shown by the dashed lines in Figure 3-24.
10. On sweeper,
 - a. Press CW F1.
 - b. Press LEVELING – POWER METER.
 - c. Push in on EXTERNAL ALC GAIN control and turn until CAL indicator comes on and stays on.

Table 3-7. Operational Checkout Procedure, LEVELING-DETECTOR and -POWER METER Controls (except 6642A) (Continued)

d. Release EXTERNAL ALC GAIN.

NOTE

The response to a changing power level is slow using a power meter; consequently, external leveling should be accomplished using either CW or a slow (99 s) sweep speed.

3-5.4 Operational Checkout Procedure, External Leveling Function (6642A)

External leveling of the RF source is provided by the front panel EXTERNAL INPUT connector and the LEVELING-DETECTOR or -POWER METER pushbutton. In this model, which uses two RF output connectors, external leveling (1) must be used

with the 26.5-40 GHz band – which does not contain an internal leveling capability – and (2) can only be used with one band at a time. That is, both the 18-26.5 and 26.5-40 GHz bands cannot be externally leveled at the same time. A test equipment setup for externally leveling the 26.5-40 GHz band is shown in Figure 3-27; the procedure for leveling the 26.5-40 GHz band is given in Table 3-8.

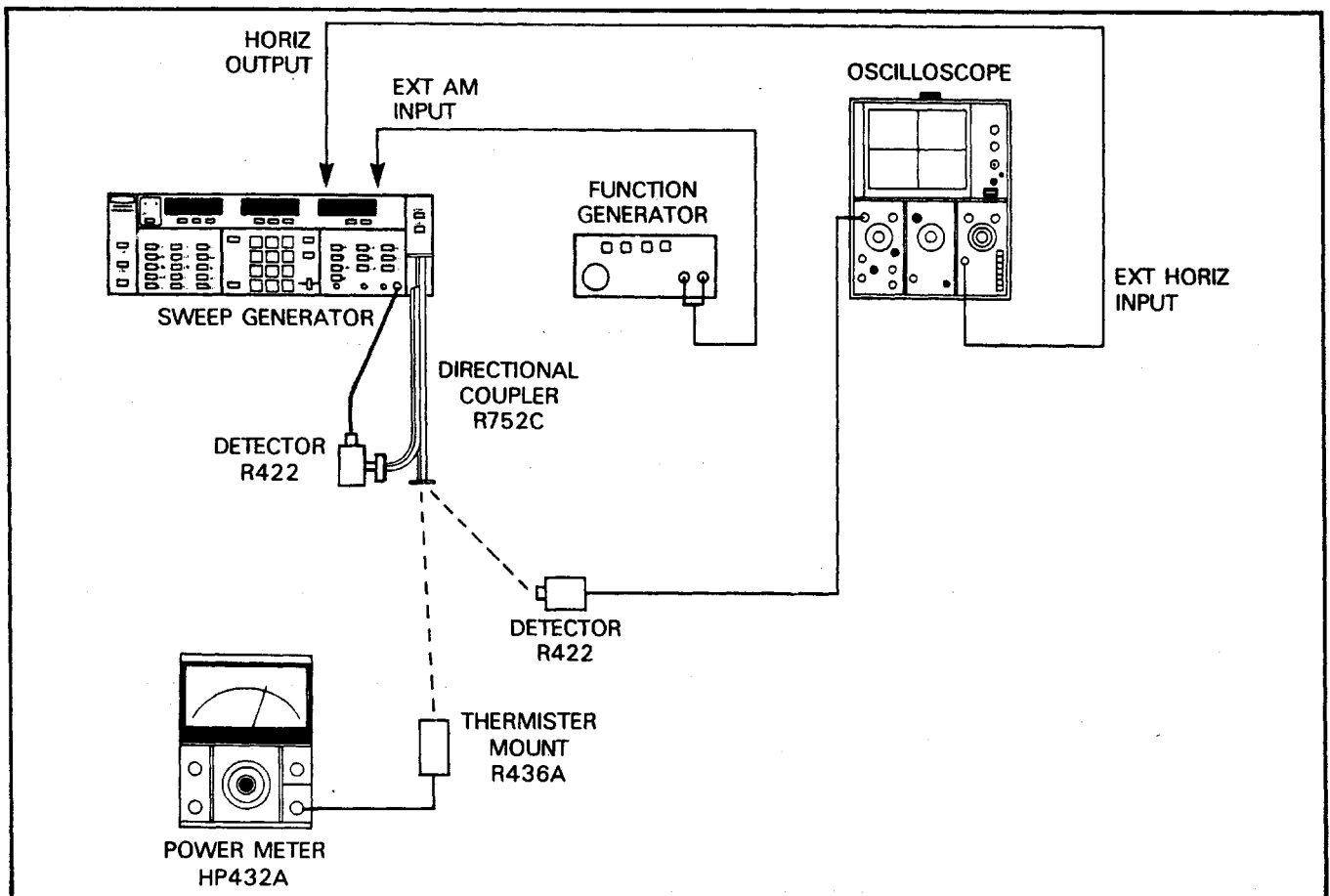

Figure 3-27. External Leveling Test Setup (6642A)

Table 3-8. Operational Checkout Procedure, LEVELING-DETECTOR
and -POWER METER Controls (6642A)

1. Connect test equipment for detector leveling, as shown in Figure 3-27. Turn the equipment on.
2. Adjust function generator for a 10 kHz, 0-300 mV square-wave output.
3. On sweeper,
 - a. Adjust RF SLOPE fully counterclockwise to OFF.
 - b. Press RESET.
 - c. Press CW F1.
 - d. Press LEVELING - DETECTOR.
4. On oscilloscope, adjust vertical and horizontal controls to obtain a square wave.
5. On sweeper, adjust EXTERNAL ALC GAIN for best square-wave response.
6. Remove the oscilloscope from the directional coupler, and connect the power meter's thermistor mount in its place.
7. On sweeper,
 - a. Adjust EXTERNAL ALC GAIN for a 0 dBm reading on power meter.
 - b. Press CW F2.
 - c. Readjust EXTERNAL ALC GAIN (if necessary) for 0 dBm power meter reading.
 - d. Press CW F1.
 - e. Repeat steps a. thru d. as necessary to obtain 0 dBm at both 27 and 40 GHz.
 - f. Press LEVEL and set for -10 dBm.
9. Observe that power meter indicates -10 dBm. If not, refer to paragraph 5-11.2 for adjustment instructions.
10. Disconnect the power meter, and connect the waveguide to the device-under-test.
11. The sweeper is now ready for making 0 to -10 dBm leveled power measurements.

3-6 DESCRIPTION OF THE IEEE-488 (IEC-625) INTERFACE BUS

The IEEE-488 bus (General Purpose Interface Bus - GPIB) is an instrumentation interface for integrating instruments, calculators, and computers into systems. The bus uses 16 signal lines to effect transfer of data and commands to as many as 15 instruments. The instruments on the bus are connected in parallel,

as shown in Figure 3-28. Eight of the signal lines (DIO 1 thru DIO 8) are used for the transfer of data and other messages in a byte-serial, bit-parallel form. The remaining eight lines are used for communications timing (handshake), control, and status information. Data is transmitted on the eight GPIB data lines as a series of eight-bit characters, referred to as bytes. Normally, a seven-bit ASCII (American Standard Code for

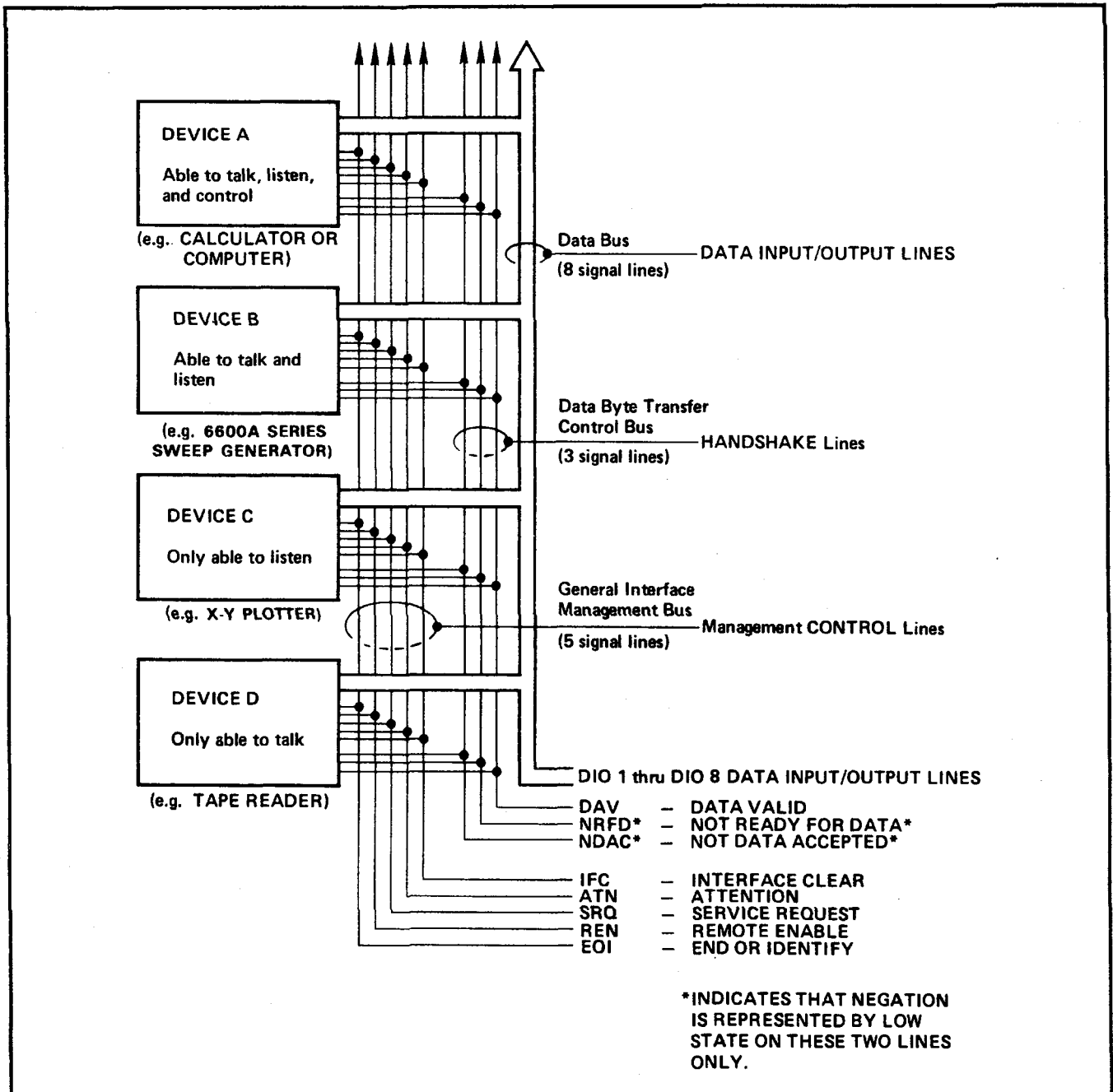

Figure 3-28. Interface Connections and Bus Structure

Information Interchange) code is used. The eighth (parity) bit is not used. Data is transferred by means of an interlocked handshake technique. This technique permits asynchronous communications over a wide range of data rates. The following paragraphs provide an overview of the data, management, and handshake buses, and describe how these buses interface with the sweep generator.

3-6.1 Data Bus Description

The data bus contains eight bi-directional, active-low signal lines – DIO 1 thru DIO 8. One byte of information (eight bits) is transferred over the bus at a time. DIO 1 represents the least-significant bit (LSB) in the byte; DIO 8 represents the most-significant bit (MSB) in the byte. Each byte represents a peripheral address (either primary or secondary), a control word, or a data byte. Data bytes are usually formatted in ASCII code, without parity. The data bus provides the conduit for transmitting control information and data between the controller and the instrument (sweep generator).

3-6.2 Management Bus Description

The management bus is a group of five signal lines that are used to control the operation of the bus system. Functional information regarding the individual management-bus control lines is provided below.

- a. ATN (attention). When this line is TRUE, the sweep generator will respond to appropriate interface messages (e.g. device clear and serial poll) and to its own listen/talk address.
- b. EOI (end or identify). This line is set TRUE during the last byte of a multi-byte message. This line is also used in conjunction with ATN to indicate a parallel-poll.
- c. IFC (interface clear). When this line is TRUE, the sweep generator interface functions are placed in a known state, i.e., unaddressed to talk, unaddressed to listen, and service request idle.

- d. REN (remote enable). When this line is TRUE, the sweep generator is enabled for entrance into the remote state (i.e., certain front panel functions disabled) upon receipt of its listen address. The remote state is exited when either (1) the REN line is FALSE (high), (2) the go-to-local (GTL) message is received, or (3) the sweep generator programming command RL (return to local) is received.
- e. SRQ (service request). This line is pulled LOW (true) by the sweep generator to indicate that certain conditions (paragraph 3-7.4) exist.

3-6.3 Data Byte Transfer Control (Handshake) Bus Description

Information is transferred on the data lines under control of a technique called the three-wire handshake. The three handshake bus signal lines are described below; Figure 3-29 shows a typical interlocking handshake operation.

- a. DAV (data valid). This line is set TRUE (arrow 1) when the talker has (1) sensed that NRFD is FALSE, (2) placed a byte of data on the bus, and (3) waited an appropriate length of time for the data to settle.
- b. NRFD (not ready for data). This line is set TRUE (arrow 2) by a listener to indicate that valid data has not yet been accepted. The time between the events shown by arrows 1 and 2 is variable, and depends upon the speed with which a listener can accept the information.
- c. NDAC (not data accepted). This line is set FALSE by a listener when the listener has accepted the current data byte for internal processing. When the data byte has been accepted, the listener releases its hold on NDAC and allows the line to go FALSE. However, because the GPIB is constructed in a wired-OR configuration, this line will not go FALSE until all listeners participating in the interchange have also released the line. As shown by the arrow labeled 3, when the NDAC line

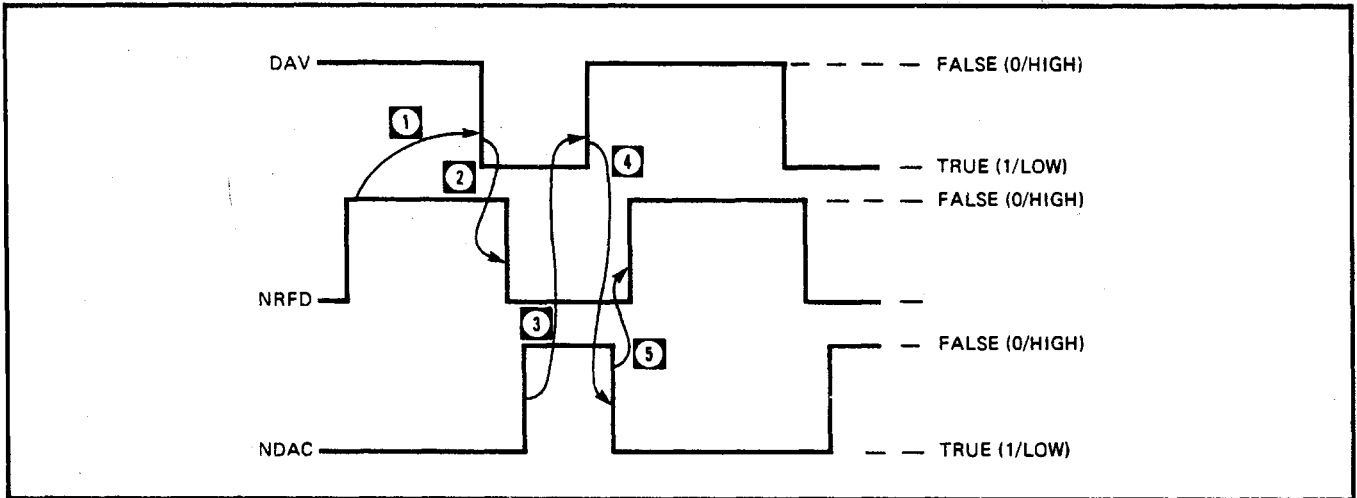

Figure 3-29. Typical Handshake Operation

goes FALSE the DAV line follows suit a short time later. The FALSE state of the DAV line indicates to the bus that valid data has been removed; consequently, with valid data no longer on the line, the NDAC line is pulled LOW again in preparation for the next data interchange. This action is shown by the arrow labeled 4.

The next action that occurs is shown by arrow 5. This arrow shows NRFD going FALSE after NDAC returns to its TRUE state. The FALSE state of NRFD indicates to the bus that all listeners are ready for the next information interchange. The time period between these last two events (NDAC going TRUE and NRFD going FALSE) is variable and is dependent upon the length of time that it takes a listener to process the data byte. Therefore, the result of the wired-OR construction of the handshake bus is that a talker is forced to wait for the slowest instrument to accept the current data before it can place a new byte of information on the bus.

3-7 GPIB OPERATION (Option 3)

The sweep generator, when equipped with Option 3, has the capability for complete front-panel-control operation over the GPIB. When used on the GPIB, the sweep generator functions as both a listener and a talker;

Figure 3-30 provides a listing showing the GPIB subset functions and gives the sweep generator's capability for each function.

To provide bus control, a system of device-dependent commands (hereafter known as bus commands) and IEEE-488 Bus Messages (hereafter known as bus messages) is used. The bus commands (approximately 100 in number) are divided into the following six classes:

1. Front Panel Control Related Commands.
2. Digital Sweep Commands.
3. Group Execute Trigger Mode Commands.
4. Service Request Mode Commands.
5. Output Commands.
6. Miscellaneous Commands.

These six classes of commands are described in paragraphs 3-7.1 thru 3-7.6, respectively. The bus messages recognized by the sweep generator are discussed in paragraph 3-7.7. In addition to bus commands and bus messages, the two types of errors that can occur with bus programming are discussed in paragraph 3-7.8. The sweep generator's default-from-reset-or-turn-on states are described in paragraph 3-7.9. A description of information supplied to provide quick reference data for GPIB programmers is given in paragraph 3-7.10. And an alphabetical index to bus command mnemonics is provided in paragraph 3-7.11.

GPIB SUBSET	FUNCTION	DESCRIPTION
AH1	Acceptor Handshake	Complete Capability
SH1	Source Handshake	Complete Capability
T6	Talker	1. Basic Talker 2. Serial Poll 3. Unaddressed if MLA 4. No Talk Only (TON)
TE0	Talker With Address Extension	No Capability
L4	Listener	1. Basic Listener 2. Unaddressed if MTA 3. No Listen Only (LON)
LE0	Listener With Address Extension	No Capability
SR1	Service Request	Complete Capability
RL1	Remote/Local	Complete Capability
PP1	Parallel Poll	Complete Capability
DC1	Device Clear	Complete Capability
DT1	Device Trigger	Complete Capability
C0	Controller	No Capability

Figure 3-30. 6600A Series Sweep Generator IEEE-488 Interface Bus Subset Capability

3-7.1 GPIB Commands: Front Panel Controls

The GPIB commands used to activate front-

panel-control functions are listed in Table 3-9. Programming examples that demonstrate the use of these commands are shown in Figure 3-31.

Table 3-9. 6600A Series Sweep Generator Front-Panel-Control-Related Commands

FRONT PANEL CONTROL	BUS COMMAND	NOTES
<p>A. DATA ENTRY</p> <p>1. <u>Parameter Entry Controls</u></p> <p>F0 F1 F2 M1 M2 ΔF SWEEP TIME RF LEVEL</p> <p>2. <u>Data Terminators</u></p> <p>GHz MHz Seconds Milliseconds dB dBm</p> <p>3. SHIFT</p> <p>4. CLEAR ENTRY</p> <p>B. FREQUENCY RANGE</p> <p>1. <u>Sweep Range Controls</u></p> <p>FULL F1-F2 M1-M2 ΔF F0 ΔF F1</p>	<p>F0XXXXGH (or MH) F1XXXXGH (or MH) F2XXXXGH (or MH) M1XXXXGH (or MH) M2XXXXGH (or MH) DLFXXXXGH (or MH) SWTXXSEC (or MS) LVLXXDM (or DB)</p> <p>GH MH SEC MS DB DM</p> <p>SH</p> <p>CLR</p> <p>FUL FF MM DF0 DF1</p>	<p>Select the sweep generator parameter and enter the parameter's value. The decimal digits (Xs) in these commands are the parameter's value in either GHz or MHz, seconds or milliseconds, dBm or dB (see below). This value is written in the same manner that it is entered from the keyboard, i.e., either an integer or decimal number (e.g. 2 or 2.21) followed by a suitable terminator (paragraph 3-2.1). The number is not limited to two or four digits; it can be any number of digits, so long as it does not exceed the limits of the instrument.</p> <p>Select parameter terminator (paragraph 3-2.1).</p> <p>Enables shifted functions (paragraph 3-2.1f) to be selected using their unshifted command codes. Example: To select an F1-F2/M1-M2 alternating sweep, program "SH FF MM".</p> <p>Clears invalid (or illegal) parameter entries (paragraph 3-2.1e).</p> <p>Select sweep range (paragraph 3-2.2a).</p>

Table 3-9. 6600A Series Sweep Generator Front-Panel-
Control-Related Commands (Continued)

FRONT PANEL CONTROL	BUS COMMAND	NOTES
<p>2. CW Frequency Select Controls</p> <p>CW F0 CW F1 CW F2 CW M1 CW M2</p>	<p>CFØ CF1 CF2 CM1 CM2</p>	<p>Select sweep range (paragraph 3-2.2b).</p>
<p>3. Frequency Vernier Controls</p> <p>INCREASE DECREASE</p> <p>OFF</p>	<p>FVSXXXE FVS-XXXE</p> <p>FVØ</p>	<p>Provide a vernier correction for the selected frequency parameter. Correction is specified in hundreds of kilohertz (paragraph 3-2.2c).</p> <p>Cancels the vernier correction (paragraph 3-2.2c).</p>
<p>C. TRIGGER Controls</p> <p>AUTO LINE EXT OR SINGLE</p> <p>MANUAL SWEEP</p>	<p>AUT LIN EXT TRS</p> <p>MAN</p>	<p>Select trigger mode (paragraph 3-2.3).</p> <p>Selects AUTO sweep. Selects LINE sweep. Selects external sweep. Triggers single sweep.</p> <p>Selects manual frequency tuning.</p>
<p>D. MARKERS Controls</p> <p>VIDEO RF INTENSITY All Markers Off</p>	<p>VM1 RM1 IM1 MKØ</p>	<p style="text-align: center;"><u>NOTE</u></p> <p>When MAN command is used, sweep tuning is accomplished using front panel controls.</p> <p>Turn on the selected marker (paragraph 3-2.4).</p> <p>Turns all markers off.</p>

Table 3-9. 6600A Series Sweep Generator Front-Panel-
Control-Related Commands (Continued)

FRONT PANEL CONTROL	BUS COMMAND	NOTES
E. LEVELING Controls		Select the leveling source (paragraph 3-2.5).
INTERNAL	IL1	
DETECTOR	DL1	
POWER METER	PL1	
No Leveling	LVØ	Turns leveling off.
F. RF Output Controls		
RF OFF	RFØ	Turns RF off.
RF ON	RF1	Turns RF on.
RETRACE	RTØ	Turns RF off during retrace.
RF Off		
RETRACE	RT1	Turns RF on during retrace (paragraph 3-2.6).
RF On		
G. POWER	None	AC power cannot be turned off and on over the interface bus.
H. SELF TEST	TST	Initiates a self-test (paragraph 3-4).
I. RESET	RST	Resets all parameters and controls to a predetermined (initialized) state (paragraph 3-2.7).
		<p style="text-align: center;"><u>NOTE</u></p> <p>The RST command causes the sweep generator's GPIB interface to become unaddressed. Therefore, RST should be used alone.</p>
J. FM OR PHASELOCK		Allows external frequency modulation or phase-lock control to be applied to the sweep generator (paragraph 3-2.2d).
Off	FMØ	
On	FM1	

EXAMPLE 1

(Assumes sweep generator set to address 5)

Sweep Range: F1-F2
F1 Frequency: 5.3 GHz
F2 Frequency: 12.6 GHz

TRIGGER: LINE
RF: On
LEVELING: INTERNAL

```
10 OUTPUT 705 ;"FF F15 3GH F212
.6GH LIN RF1 IL1"
```

EXAMPLE 2

(Assumes sweep generator set to address 5)

Sweep Range: ΔF F0
F0 Frequency: 2 GHz
ΔF Frequency: 10 MHz
TRIGGER: AUTO

FM OR PHASELOCK: On
Set Vernier: -7.5 MHz
LEVELING: INTERNAL
RF: On

```
10 OUTPUT 705 ;"DF0 F02GH DLF10M
H RUT FM1 FVS-75E IL1 RF1"
```

Figure 3-31. GPIB Front Panel Programming Examples

3-7.2 GPIB Commands: Step Sweep

To provide a high-resolution sweep over a narrow band of frequencies, the sweep generator is equipped with a digitally stepped sweep (step sweep). This sweep, which contains 4096 discrete points, can be incrementally stepped so that any number (or all) of the discrete points can be used. The width of the step sweep and the frequency start and stop points (or center frequency for a ΔF sweep) are selected using front-panel-control command statements. (Example: FF F1XXXXGH F2XXXXGH, DF0 F0XXXXGH, DLFXXXXMH, or MM M1XXXXMH

M2XXXXMH.) Because the step sweep is a frequency sweep, the following apply:

- a. The front panel LED displays remain unchanged as the sweep progresses from start to stop.
- b. The frequencies corresponding to the step sweep's intermediate steps must be calculated. The formula for calculating step sweep frequencies is given in Appendix 2.

The step sweep commands are given in Table 3-10.

Table 3-10. 6600A Series Sweep Generator Digital Sweep Commands

NAME	COMMAND	FUNCTION
Step Sweep	STP	Selects the Step Sweep mode of operation.
Step Select	STSXXXXE	Selects the increment point at which the Step Sweep starts. This sweep start can be any point from 0 to 4095. Zero is the usual starting point, in which case STS0E (or STSE) is the command to use.

Table 3-10. 6600A Series Sweep Generator Digital Sweep Commands (Continued)

NAME	COMMAND	FUNCTION
Increment Size	SIZXXXXE	<p>Selects the number of steps by which the Step Sweep is to be incremented when an "N" command (see below) is received. Also, selects the number of steps in which an "UP" or "DN" command (Table 3-14) will increment the selected parameter (paragraph 3-2.1a).</p> <p>The Xs in this command represent digits. A maximum of 4 and a minimum of 0 digits may be used. The number that is formed by the digits <u>must be an integer</u>. If a fractional number is used, any digits that appear to the right of the decimal point are ignored. (Example: SIZ146E and SIZ146.5E are equivalent commands.)</p>
Go to Next Step	N	<p>Increments the Step Sweep by the number of steps programmed with the Increment Size Command.</p> <p>The following is an example of the syntax required to implement a step sweep that starts at 0 volts, has an increment size of 819 steps, and takes data at 5 discrete frequency points:</p> <pre> 10 OUTPUT 705;* "STP STSE SIZ819E" 20 FOR I = 0 TO 4 30 • 40 • Input Statements, etc. 50 • 60 OUTPUT 705; "N" 70 NEXT I </pre> <p>*Assumes sweep generator address is 5.</p>

3-7.3 GPIB Commands: Group Execute Trigger Modes

To speed up bus operations, the Group Execute Trigger (GET) bus message can be used to increment or decrement frequency,

sweep time, or output-power level. The GET bus message can also be used to increment or decrement the step sweep. The bus commands that configure the sweep generator for this increase/decrease response to a GET bus message are listed in Table 3-11.

Table 3-11. 6600A Series Sweep Generator Group
Execute Trigger (GET) Mode Commands

NAME	COMMAND	FUNCTION
Trigger Single Sweep	GTS	Configures the sweep generator to execute a single sweep each time a GET bus message is received. This is the default mode, i.e., the mode assumed when no GET Mode command is programmed.
Increment-Selected Parameter	GTU	Configures the sweep generator to execute an "UP" command (Table 3-14) each time a GET bus message is received.
Decrement-Selected Parameter	GTD	Configures the sweep generator to execute a "DN" command (Table 3-14) each time a GET bus message is received.
Go to Next Step	GTN	Configures the sweep generator to execute an "N" command (Table 3-10) each time a GET bus message is received.

3-7.4 GPIB Commands: Service Request Modes

To notify the controller that certain conditions exist (such as end-of-sweep, marker encountered, unlevelled, and error entry), the

sweep generator uses the GPIB Service Request function. To use this function, the sweep generator employs a system of Service Request mode commands; these commands are described in Table 3-12.

Table 3-12. 6600A Series Sweep Generator Service Request (SRQ) Commands

NAME	COMMAND	FUNCTION
Enable SRQ Capability	SQ1	Enables the following SRQ mode commands to request service from the controller.
Disable SRQ Capability	SQ0	Disables the SRQ function. This is the default mode, i.e., the mode assumed when neither SQ1 nor SQ0 is programmed.
<u>Dwell-at-Marker Mode:</u> On	DW1	Activates the dwell-at-marker mode. In this mode, when an intensity marker is encountered, the frequency sweep will dwell at the marker until a Continue Sweep (CNT) command is received. When DW1 and SQ1 are

Table 3-12. 6600A Series Sweep Generator Service Request (SRQ) Commands (Continued)

NAME	COMMAND	FUNCTION
<p><u>Dwell-at-Marker Mode</u> (continued):</p> <p>Off</p>	<p>DW0</p>	<p>both programmed, the SRQ line is pulled LOW (true), and Status Byte (Figure 3-32) bits 0 and 6 are set HIGH (decimal 65). When DW1 and SQ0 are both programmed, only the Status Byte is generated; the SRQ line is not activated.</p> <p>Deactivates the dwell-at-marker mode. This is the default mode, i.e., the mode assumed when neither DW1 nor DW0 is programmed.</p>
<p><u>End-of-Sweep Mode:</u></p> <p>On</p> <p>Off</p>	<p>ES1</p> <p>ES0</p>	<p>Activates the end-of-sweep mode. When ES1 and SQ1 are both programmed, the ending of the frequency sweep causes the SRQ line to be pulled LOW (true) and Status Byte bits 1 and 6 to be set HIGH (decimal 66). When ES1 and SQ0 are both programmed, only the Status Byte is generated; the SRQ line is not activated.</p> <p>Deactivates end-of-sweep mode. This is the default mode, i.e., the mode assumed when neither ES1 nor ES0 is programmed.</p>
<p><u>Unleveled Condition Mode:</u></p> <p>On</p> <p>Off</p>	<p>UL1</p> <p>UL0</p>	<p>Activates the unleveled-condition mode. When UL1 and SQ1 are both programmed, an unleveled output-power condition causes the SRQ line to be pulled LOW (true) and Status Byte bits 2 and 6 to be set HIGH (decimal 68). When UL1 and SQ0 are both programmed, only the Status Byte is generated; the SRQ line is not activated.</p> <p>Deactivates the unleveled condition mode. This is the default mode; i.e., the mode assumed when neither UL0 nor UL1 is programmed.</p>
<p><u>Parameter-Entry Error Mode:</u></p> <p>On</p>	<p>PE1</p>	<p>Activates the parameter-entry error mode. When PE1 and SQ1 are both programmed, a parameter-entry error (paragraph 3-7.8) causes the SRQ line to be pulled LOW (true) and Status Byte bits 4 and 6 to be set HIGH (decimal 80). When PE1 and SQ0 are both programmed, only the Status Byte is generated; the SRQ line is not activated.</p>

Table 3-12. 6600A Series Sweep Generator Service Request (SRQ) Commands (Continued)

NAME	COMMAND	FUNCTION
<u>Parameter-Entry Error Mode</u> (continued): Off	PE \emptyset	Deactivates the parameter-entry error mode. This is the default mode; i.e., the mode assumed when neither PE \emptyset nor PE1 is programmed.
<u>Syntax Error Mode:</u> On	SE1	Activates the syntax error mode. When SE1 and SQ1 are both programmed, a syntax error (paragraph 3-7.8) causes the SRQ line to be pulled LOW (true) and Status Byte bits 5 and 6 to be set HIGH (decimal 96). When SE1 and SQ \emptyset are both programmed, only the Status Byte is generated; the SRQ line is not activated.
Off	SE \emptyset	Deactivates the syntax error mode. This is the default mode, i.e., the mode assumed when neither SE \emptyset nor SE1 is programmed.

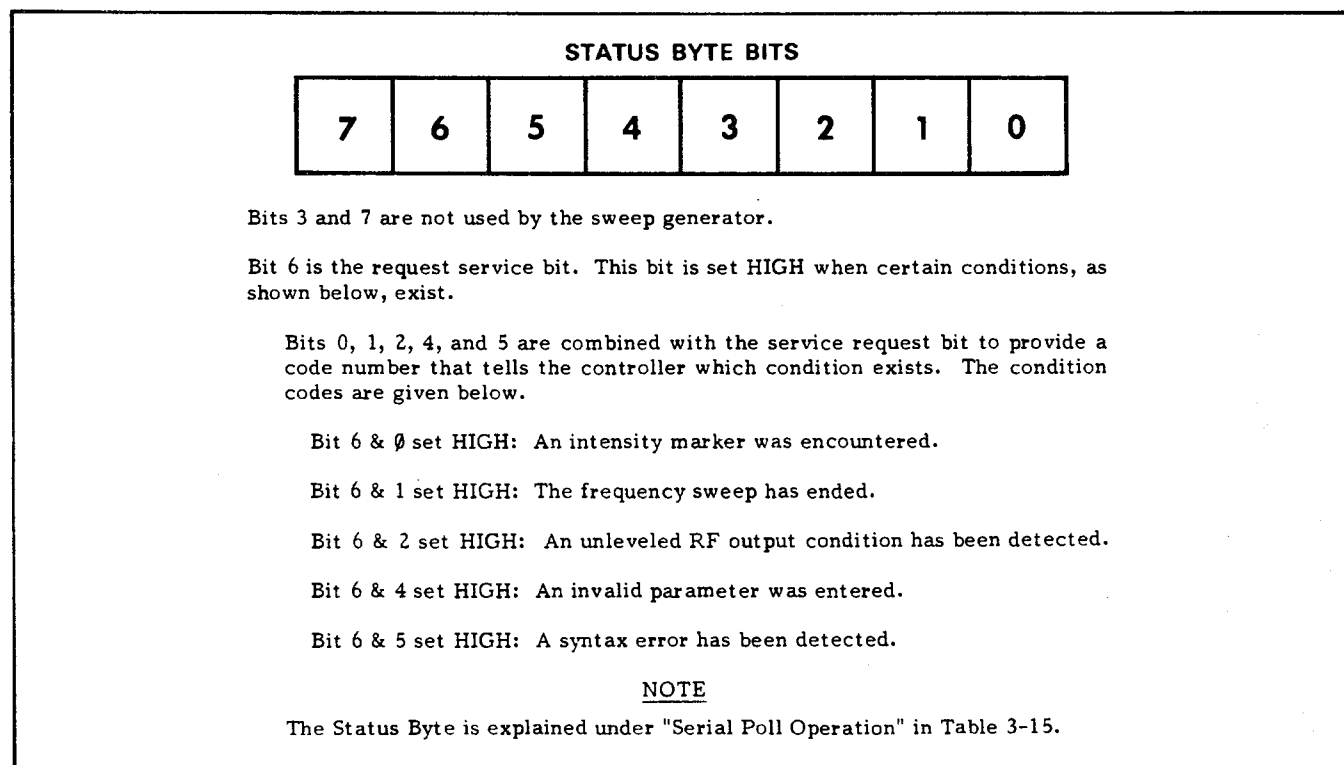

Figure 3-32. Sweep Generator Status-Byte Coding

3-7.5 GPIB Commands: Output

To provide equipment identification and parameter information upon request, the sweep generator is equipped with output

commands. The use of these commands causes the sweep generator to output the requested information when next addressed to talk. These output commands are given in Table 3-13.

Table 3-13. 6600A Series Sweep Generator Output Commands

NAME	COMMAND	FUNCTION														
Output Identify	OI	<p>Causes the sweep generator to identify itself by sending certain parameter information over the bus. This parameter information consists of model number, low-end frequency, high-end frequency, minimum output-power level, maximum output-power level, and software revision number. This command can be used to send parameter information to the controller automatically, thus relieving the operator from having to input the information manually. The format in which the OI data is returned is shown below.</p> <table style="margin-left: auto; margin-right: auto;"> <tr> <td style="text-align: left;">Number of Bytes</td> <td style="text-align: center;"><u>4</u></td> <td style="text-align: center;"><u>5</u></td> <td style="text-align: center;"><u>5</u></td> <td style="text-align: center;"><u>6</u></td> <td style="text-align: center;"><u>4</u></td> <td style="text-align: center;"><u>4</u></td> </tr> <tr> <td style="text-align: left;">Data</td> <td style="text-align: center;">6636A</td> <td style="text-align: center;">18.00</td> <td style="text-align: center;">26.50</td> <td style="text-align: center;">-005.0</td> <td style="text-align: center;">05.0</td> <td style="text-align: center;">01.7</td> </tr> </table>	Number of Bytes	<u>4</u>	<u>5</u>	<u>5</u>	<u>6</u>	<u>4</u>	<u>4</u>	Data	6636A	18.00	26.50	-005.0	05.0	01.7
Number of Bytes	<u>4</u>	<u>5</u>	<u>5</u>	<u>6</u>	<u>4</u>	<u>4</u>										
Data	6636A	18.00	26.50	-005.0	05.0	01.7										
Output ΔF Parameter	ODF	Returns the value of the ΔF frequency parameter to the controller, value is given in MHz.														
Output $F\emptyset$ Parameter	OF \emptyset	Returns the value of the $F\emptyset$ frequency parameter to the controller. Value is given in MHz.														
Output F1 Parameter	OF1	Returns the F1 frequency value, as described above.														
Output F2 Parameter	OF2	Returns the F2 frequency value, as described above.														

Table 3-13. 6600A Series Sweep Generator Output Commands (Continued)

NAME	COMMAND	FUNCTION
Output F _{low}	OFL	Returns the low-end frequency value, as described above.
Output F _{high}	OFH	Returns the high-end frequency value, as described above.
Output M1 Parameter	OM1	Returns the M1 frequency value, as described above.
Output M2 Parameter	OM2	Returns the M2 frequency value, as described above.
Output Power Level	OLV	Returns the output-power level value to the controller. Value is given in ± 0.1 dB increments.
Output Status Byte	OSB	Returns the Status Byte (Figure 3-32) to the controller.
Output Sweep Time	OST	Returns the sweep time value to the controller. Value is given in milliseconds.

3-7.6 GPIB Commands: Miscellaneous

There are 9 GPIB commands unrelated to either front-panel, digital-sweep, GET-mode,

SRQ-mode or output operation. These miscellaneous commands are described in Table 3-14.

Table 3-14. 6600A Series Sweep Generator Miscellaneous Commands

NAME	COMMAND	FUNCTION
Continue Sweep	CNT	Causes the sweep to continue after having dwelled at an intensity marker. CNT is used in conjunction with the SRQ Dwell-at-Marker Mode.
<u>Front Panel Displays:</u>		
Off	DS0	Turns off the front panel numeric displays so that unauthorized personnel cannot read the frequency range currently in use.
On	DS1	Turns the front panel numeric displays on. This is the default, or unprogrammed, condition (paragraph 3-7.9).

Table 3-14. 6600A Series Sweep Generator Miscellaneous Commands (Continued)

NAME	COMMAND	FUNCTION
Decrement the Selected Parameter	DN	Decrements the selected frequency, sweep time, or RF level parameter by the number of steps programmed with the Increment Size command (SIZ). For DN to be effective, the selected parameter must still be active. That is, the selected parameter's command statement (F1XXXXGH, SWTXXMS, LVLXXDM, etc.) must be the last command to appear before DN is commanded. A non-parameter command, such as AUT, IL1, or VM1, cannot be sandwiched between the parameter mnemonic and the DN command. If necessary, ensure that the selected parameter is still active by prefacing DN (or a string of DNs) with the selected parameter's mnemonic. For example, send F1 DN (or DN DN DN etc.) rather than just DN (or DN DN DN etc.).
Increment the Selected Parameter	UP	Increments the selected frequency, sweep time, or RF level parameter by the number of steps programmed with the Increment Size command (SIZ). As described for the DN command, above, the selected parameter must still be active for UP to be effective.
<u>CW Filter:</u>		
Out	FL0	Causes the CW filter to be out of the RF output signal line.
In	FL1	Inserts a CW filter in the RF output signal line. This command overrides the CW filter control inherent in front-panel programming (i.e., CW filter inserted for sweep widths 50 MHz and below and not inserted for sweep widths above 50 MHz).
Return to Local	RL	Causes the sweep generator to return to local (front panel) control, provided that a local lockout message (Table 3-15) is not in effect.
Recall the Front Panel Control Settings	RCL	Causes the sweep generator to be reconfigured with the front-panel-control settings that were previously saved using the SAV command (below). Figure 3-33 provides a programming example.
<u>Horizontal Output During CW</u>		
OFF	CS0	Operation is the same as that described for the CW RAMP function in paragraph 3-2.1f.3.
ON	CS1	

3-7.7 Bus Messages

The 6600 Series Sweep Generators recognize most of the IEEE-488 bus messages. A listing of the recognized bus messages, including specific information describing how the

messages are used, is given in Table 3-15. Sample program statements showing how the WILTRON 85/HP9845A, HP 9825A, and Tektronix 4051/4052 bus controllers implement the recognized bus messages are shown in Table 3-16.

Table 3-15. Bus Messages Recognized by the 6600A Series Sweep Generators

BUS MESSAGE	HOW MESSAGE IS USED BY SWEEP GENERATOR
Device Clear	<ol style="list-style-type: none"> 1. Aborts all current sweep generator GPIB activities. 2. Resets the STS, SIZ, SQ1, DW1, UL1, ES1, EF, and EI commands to their default condition (paragraph 3-7.9).
Go to Local	Returns the sweep generator to local control.
Group Execute Trigger	<ol style="list-style-type: none"> 1. Triggers a new sweep if the EXT (Table 3-9) and the GTS (Table 3-11) commands are both programmed. 2. Increments the selected parameter (paragraph 3-2.1a) by the number of steps programmed using the SIZ command (Table 3-10) if the GTU command (Table 3-11) is programmed. 3. Decrements the selected parameter by the number of steps programmed using the SIZ command if the GTD command (Table 3-11) is programmed. 4. Increments the digital sweep by the number of steps programmed using the SIZ command if the GTN command (Table 3-11) is programmed.
Interface Clear	Stops the sweep generator GPIB interface from listening or talking. The front panel controls <u>are not</u> cleared.
Local Lockout	Prevents the RETURN TO LOCAL pushbutton or the RL command (Table 3-14) from returning the sweep generator to local control.
Remote Enable	Places the sweep generator under remote control if the REM line is TRUE and the sweep generator is addressed to listen. If placed in remote and not supplied with program data, sweep generator operation is determined by the position in which the front panel controls were set immediately prior to going remote.
<u>Service Request (SRQ) Messages:</u>	The sweep generator is equipped with SRQ capability. It will respond to both serial- and parallel-poll messages. Serial- and parallel-poll operations are described below.

Table 3-15. Bus Messages Recognized by the
6600A Series Sweep Generators (Continued)

BUS MESSAGE	HOW MESSAGE IS USED BY SWEEP GENERATOR
<p>Serial-Poll Enable (SPE)</p> <p>Serial-Poll Disable (SPD)</p>	<p style="text-align: center;"><u>Serial Poll Operation</u></p> <p>The SPE message causes the sweep generator to respond with a decimally-coded status byte (Figure 3-32). This status byte is coded to give the controller two pieces of information:</p> <ol style="list-style-type: none"> 1. Whether it was the device requesting service. 2. If it was the service-requesting device, the type of service that it needs. <p>The SPD message, which is sent by the controller in response to receiving a status byte, terminates serial-poll operation.</p>
<p>Parallel-Poll Configure (PPC)</p> <p>Parallel-Poll Enable (PPE)</p> <p>Parallel-Poll Unconfigure (PPU)</p> <p>Parallel-Poll Disable (PPD)</p>	<p style="text-align: center;"><u>Parallel-Poll Operation</u></p> <p>When queried by a parallel-poll message command (PPOLL or pol; see Table 3-16), the sweep generator (if configured for parallel-poll operation; see below) responds by setting its assigned data bus line to the logical state (1, 0) that indicates its correct SRQ status.</p> <p>To configure a bus device that is (1) built for parallel-poll operation and (2) designed to be remotely configured on the bus, the controller sends a two-byte parallel-poll configure and enable (PPC and PPE) message.</p> <p>The PPC byte configures the device to respond to a parallel-poll message such as PPOLL or pol. The PPE byte assigns the logical sense (1, 0) that the parallel-poll response will take.</p> <p>When the sweep generator receives the PPC/PPE message, it configures itself to properly respond to the parallel-poll message.</p> <p>The PPU (or PPD) message is sent by the controller when a parallel-poll response is no longer desired. This message causes the sweep generator to become unconfigured for parallel-poll response.</p>

Table 3-16. Sample Bus Message Statements

BUS MESSAGE	SAMPLE STATEMENT SHOWING HOW MESSAGE IS IMPLEMENTED		
	MODELS 85/9845A	HP 9825	TEKTRONIX 4051
Go to Local (GTL)	LOCAL 7 ¹ LOCAL 705 ²	lcl 7 ¹ lcl 705 ²	WBYTE Ω 9 ₂ , 63, 37, 4:
Group Execute Trigger (GET)	TRIGGER 7 TRIGGER 705	trg 7 trg 705	WBYTE Ω 9 ₂ , 63, 37, 8:
Interface Clear (IFC)	ABORTIO 7 ABORTIO 705	cli 7 cli 705	
Local Lockout (LLO)	LOCAL LOCKOUT 7	llo 7	WBYTE Ω 17: ¹
Remote Enable	REMOTE 7 REMOTE 705	rem 7 rem 705	PRINT Ω 5 ²
Serial Poll (Query Message)	SPOLL (7) SPOLL (705)	rds (7)→A: if bit (7, A); gto (Line No.)	POLL A, B; 5 ²
Parallel Poll (Query Message)	PPOLL (7)	pol(7)→A: if bit (0, A) = 1; gsb "Serv 0": if bit (1, A) = 1; gsb "Serv 1"	
Parallel Poll Configure (PPC) (The statements assign the sweep generator data line DIO5 for parallel-poll response with Sense (S) = 0.)	<u>MODEL 85 ONLY:</u> SEND 7; LISTEN 5 CMD 3 SCG 5 UNL <u>HP 9845 ONLY:</u> PPOLL CONFIGURE 705; 5	polc 705, 5 ²	

¹ Sends message to all bus instruments.

² Sends message to instrument at address 5 (sweep generator).

Table 3-16. Sample Bus Message Statements (Continued)

BUS MESSAGE	SAMPLE STATEMENT SHOWING HOW MESSAGE IS IMPLEMENTED		
	MODELS 85/9845A	HP 9825	TEKTRONIX 4051
Parallel Poll Unconfigure (PPU)	<p><u>MODEL 85 ONLY:</u></p> <p>SEND 7; LISTEN 5 CMD 21</p> <p><u>HP 9845 ONLY:</u></p> <p>PPOLL UNCONFIGURE 705</p>	<p>polu 7</p> <p>polu 705</p>	
Device Clear (DC and SDC)	<p><u>MODEL 85 ONLY:</u></p> <p>CLEAR 7 CLEAR 705</p> <p><u>HP 9845 ONLY:</u></p> <p>RESET 7 RESET 705</p>	<p>clr 7</p> <p>clr 705</p>	<p>INIT¹</p> <p>WBYTE Ω 95, 63, 37, 4:²</p>

¹ Sends message to all bus instruments.

² Sends message to instrument at address 5 (sweep generator).

3-7.8 Program Errors

There are two types of errors that occur in bus programming: invalid-parameter errors and syntax errors. These two error types are described below.

a. Invalid-Parameter Error. Invalid-parameter errors are those that will cause either the front panel CLEAR ENTRY, F1>F2 OR M1>M2 CHANGE FREQ SETTING, or GHz/dBm/Sec and MHz/dB/mS indicators to flash. These errors include:

1. Programming a frequency sweep where F1 is greater than F2 or M1 is greater than M2 (backward sweep, paragraph 3-2.1e).

2. Attempting to enter a frequency, sweep-time, or RF level parameter that exceeds the limits of the sweep generator.
3. Failing to properly end a parameter entry with a suitable terminator, such as MH, DB, MS, etc.

Invalid-parameter errors cause the front-panel indicators to flash.

- b. Syntax Errors. Syntax errors are errors that occur in the formulation of a program statement, such as writing "EXTTFS" instead of "EXTTRS". To prevent misinterpretation of command statements, the sweep generator ignores

all portions of the command statement following the syntax error. All commands are ignored until the sweep generator receives the Unlisten command (ASCII ?)

over the bus or until the sweep generator is addressed to talk. An example showing how the sweep generator evaluates a syntax error is given in Figure 3-34.

Correctly-written program statement commanding external sweep, trigger sweep, and RF marker (sweep generator assumed to be set to address 5):

10 OUTPUT 705; "EXTTRSRM1"

Same program statement with syntax error.

10 OUTPUT 705; "EXTTFSRM1"

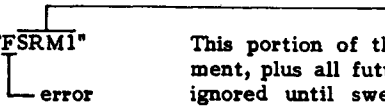

This portion of the program statement, plus all future statements, is ignored until sweep generator receives the Unlisten (UNL) command (ASCII ?). The Unlisten Command is normally sent over the bus either (1) immediately prior to the next time the sweep generator is addressed (HP 9825 or Model 85, see below) or (2) immediately after the last data byte of the current data transaction has been received (TEK 4051 and PET 2001).

Program Format, HP 9825A and Model 85

1st Data Transaction	2nd Data Transaction
U L D A T A	U L D A T A
N I))))	N I))))
L S))))	L S))))
I T))))	I T))))
S))))	S))))
T A))))	T A))))
E D))))	E D))))
N D))))	N D))))
R))))	R))))

Program Format, TEK 4051 & PET 2001

1st Data Transaction	2nd Data Transaction
L D A T A U	L D A T A U
I)))) N	I)))) N
S)))) L	S)))) L
T)))) I	T)))) I
A)))) S	A)))) S
D)))) T	D)))) T
D)))) E	D)))) E
R)))) N	R)))) N

Figure 3-34. Program Statement with Syntax Error (Example)

3-7.9 Reset Programming and Default Conditions

Reset programming provides the means for quickly returning the sweep generator to its default (preprogrammed) operational state. In the manual (local) mode, the default state can be entered into only by pressing the RESET pushbutton. In the GPIB (remote) mode, however, there are several ways in which to enter the default state. These

reset-programming methods, along with related data, are given in Table 3-17. The default settings for the numeric frequency, sweep time, and output power level parameters are the same as those given for the RESET pushbutton (Table 3-1). A recommended command sequence for reset programming is given in Figure 3-35. The use of this recommended command sequence assures that all parameters and commands assume their preprogrammed state each time reset is desired.

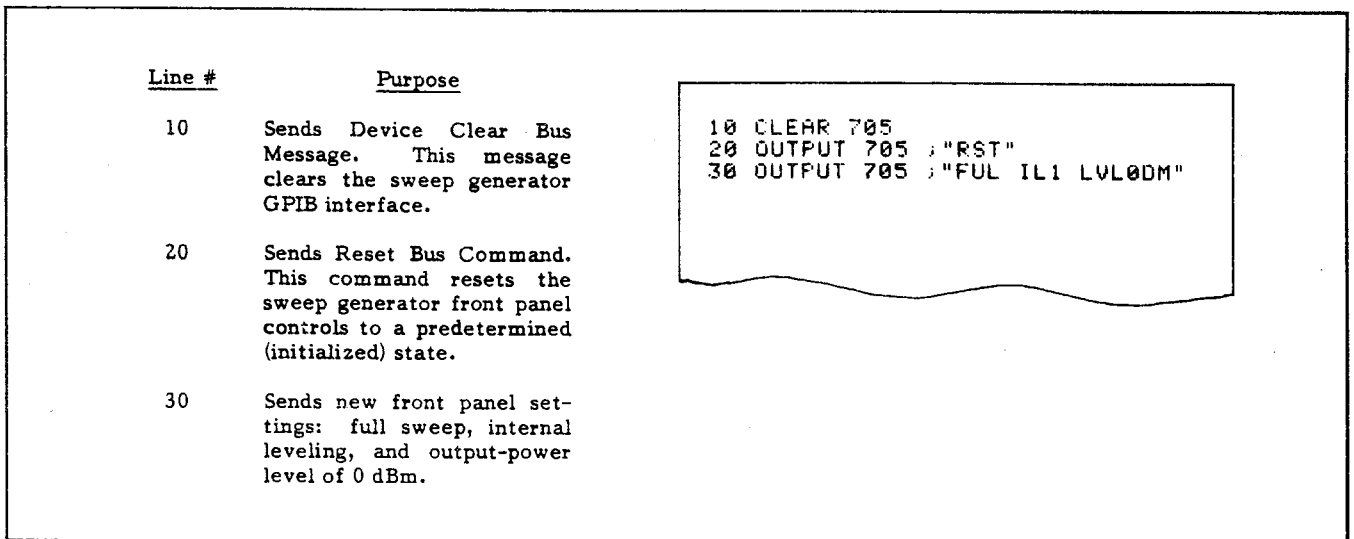

Figure 3-35. Reset Programming Statements

Table 3-17. Resetting the Sweep Generator GPIB Interface Circuits

METHODS OF RESETTNG GPIB INTERFACE CIRCUITS	FUNCTIONS AFFECTED	DEFAULT CONDITION
1. Pressing RETURN TO LOCAL pushbutton.	Digital Sweep	STS = 0 SIZ = 0
	Service Request Modes	SQ0 DW0 UL0 ES0
	Group Execute Trigger Mode	GTS
	Bus Messages	Local

Table 3-17. Resetting the Sweep Generator GPIB Interface Circuits (Continued)

METHODS OF RESETTING GPIB INTERFACE CIRCUITS	FUNCTIONS AFFECTED	DEFAULT CONDITION
2. Pressing RESET pushbutton.	Same as above.	Same as above, plus local and local lockout messages are also reset.
3. Sending RST command over the bus.	Same as above.	Same as 2, above.
4. Executing the interface message Device Clear.	Same as above.	Same as 1, above, except local bus message is not reset.
5. Turning the POWER switch on and off.	Same as above	Same as 2, above.

3-7.10 Quick Reference Data

An alphabetical index of sweep generator GPIB command codes, along with a tabulation of default data, is provided in Appendix 1. This appendix may be copied and used as a handy source for the quick reference of certain GPIB programming data.

3-7.11 Index of Sweep Generator GPIB Command Codes

An alphabetical index of the sweep generator GPIB command codes is given in Table 3-18. This table lists the command mnemonic, the name of the command, and the table number where the command is described.

Table 3-18. Index of Sweep Generator GPIB Command Mnemonics

MNE-MONIC	NAME	TABLE NO.
AUT	Auto Trigger	3-9
CF0	CW Select F0	3-9
CF1	CW Select F1	3-9
CF2	CW Select F2	3-9
CLR	Clear Keypad	3-9
CM1	CW Select M1	3-9
CM2	CW Select M2	3-9
CNT	Continue Sweep	3-14
CS0	Horizontal Output Off During CW Operation	3-14
CS1	Horizontal Output On During CW Operation	3-14
DB	dB Data Terminator	3-9

MNE-MONIC	NAME	TABLE NO.
DF0	Sweep Range ΔF F0	3-9
DF1	Sweep Range ΔF F1	3-9
DL1	Detector Leveling	3-9
DLF	Enter ΔF Frequency	3-9
DM	dBm Data Terminator	3-9
DN	Decrement Selected Parameter	3-14
DS0	Front Panel Displays Off	3-14
DS1	Front Panel Displays On	3-14
DW0	Dwell at Marker Mode Off	3-12
DW1	Dwell at Marker Mode On	3-12
ES0	End of Sweep Mode Off	3-12

Table 3-18. Index of Sweep Generator GPIB Command Mnemonics (Continued)

MNE-MONIC	NAME	TABLE NO.	MNE-MONIC	NAME	TABLE NO.
ES1	End of Sweep Mode On	3-12	OFH	Output High-End Frequency	3-13
EXT	External Trigger	3-9	OLV	Output RF Level	3-13
F0	Enter Parameter F0	3-9	OM1	Output M1 Frequency	3-13
F1	Enter Parameter F1	3-9	OM2	Output M2 Frequency	3-13
F2	Enter Parameter F2	3-9	OSB	Output Status Byte	3-13
FF	Sweep Range F1-F2	3-9	OST	Output Sweep Time	3-13
FL0	CW Filter Off	3-14	PE0	Parameter Entry Error Mode Off	3-12
FL1	CW Filter On	3-14	PE1	Parameter Entry Error Mode On	3-12
FM0	Frequency Modulation Off	3-9	PL1	Power Meter Leveling	3-9
FM1	Frequency Modulation On	3-9	RCL	Recall Front Panel Setup	3-14
FUL	Sweep Range Full	3-9	RF0	RF Off	3-9
FV0	Frequency Vernier Off	3-9	RF1	RF On	3-9
FVS	Set Frequency Vernier	3-9	RL	Return to Local	3-14
GH	GHz Data Terminator	3-9	RM1	RF Marker On	3-9
GTD	GET* Mode Execute "DN" Command	3-11	RSS	Reset Sweep	3-14
GTN	GET Mode Execute "N" Command	3-11	RST	Reset Front Panel	3-9
GTS	GET Mode Trigger Sweep	3-11	RT0	RF During Retrace Off	3-9
GTU	GET Mode Execute "UP" Command	3-11	RT1	RF During Retrace On	3-9
IL1	Internal Leveling	3-9	SAV	Save Front Panel Setup	3-14
IM1	Intensity Marker	3-9	SE0	Syntax Error Mode Off	3-12
LIN	Line Trigger	3-9	SE1	Syntax Error Mode On	3-12
LV0	Leveling Off	3-9	SEC	Seconds Data Terminator	3-9
LVL	Enter Level Parameter	3-9	SH	Shift	3-9
M1	Enter M1 Parameter	3-9	SIZ	Increment Size	3-10
M2	Enter M2 Parameter	3-9	SQ0	SRQ Mode Off	3-12
MAN	Manual Sweep	3-9	SQ1	SRQ Mode On	3-12
MH	MHz Data Terminator	3-9	STP	Step Sweep	3-10
MK0	Markers Off	3-9	STS	Step Select	3-10
MM	Sweep Range M1-M2	3-9	SWT	Enter Sweep Time Parameter	3-9
MS	Millisecond Data Terminator	3-9	TRS	Trigger Sweep	3-9
N	Go to Next Increment (Digital Sweep)	3-10	TST	Self-Test	3-9
ODF	Output ΔF Frequency	3-13	UL0	Unleveled Condition Mode Off	3-12
OI	Identify Instrument	3-13	UL1	Unleveled Condition Mode On	3-12
OF0	Output F0 Frequency	3-13	UP	Increment Selected Parameter	3-14
OF1	Output F1 Frequency	3-13	VM1	Video Marker On	3-9
OF2	Output F2 Frequency	3-13			
OFL	Output Low-End Frequency	3-13			

*Group Execute Trigger

SECTION IV

PERFORMANCE VERIFICATION

4-1 INTRODUCTION

This section contains the performance verification procedures, which are organized as follows:

<u>Para.</u>	<u>Test</u>
4-3	FREQUENCY ACCURACY
4-4	SWEEP TIME
4-5	OUTPUT POWER
4-6	RESIDUAL AM
4-7	RESIDUAL FM
4-8	EXTERNAL FM AND PHASE LOCK
4-9 thru 4-11	RF OUTPUT SIGNAL

4-2 RECOMMENDED TEST EQUIPMENT

A listing of the test equipment required for performance verification and for calibration (Section V) is given in Table 4-1.

4-3 FREQUENCY ACCURACY TESTS

To verify the sweep generator's frequency accuracy, perform the steps in subparagraphs a. thru c. below. If any of the frequencies are found to be out of tolerance, perform the A5 Frequency Instruction adjustments in paragraph 5-6 and the applicable Frequency Calibration adjustments in paragraph 5-9.

a. CW Frequency Accuracy

1. Connect the test equipment as shown in Figure 4-1, and turn the equipment on.
2. Press RESET on the sweep generator (sweeper).
3. Press CW F1.

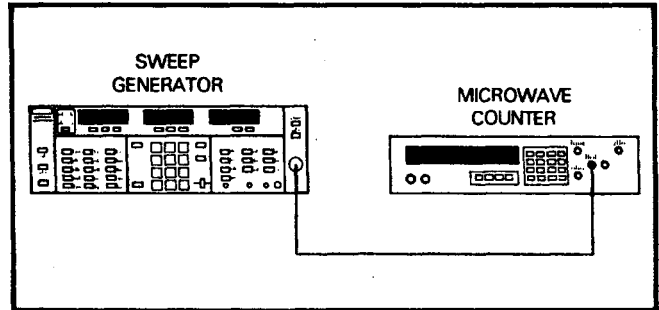

Figure 4-1. Test Equipment Setup for Frequency Accuracy Tests

4. For all models except the 6642A: Verify that F1 is accurate to within ± 10 MHz (± 20 MHz for the 6653A and 6659A) at the following frequencies:
 - (a) Low end of the frequency range.
 - (b) High end of the frequency range.
 - (c) Each applicable bandswitch point ± 50 MHz (that is, 1.950 & 2.050 GHz, 7.950 & 8.050 GHz, 12.350 & 12.450 GHz, and 17.950 & 18.050 GHz).
 - (d) Each 1 GHz of tuning.
5. For the 6642A: Verify that F1 displays the following accuracies:
 - (a) ± 15 MHz - for the low end of the frequency range and each 1 GHz of tuning up to 26.000 GHz.
 - (b) ± 20 MHz - at 26.550 GHz and each 1 GHz of tuning up to 40 GHz.
6. Press RESET.
7. Sequentially press CW F0, CW F2, CW M1, and CW M2; verify that each CW parameter indicates its RESET frequency (Table 4-2).

Table 4-1. Recommended Test Equipment for Performance Verification and Calibration

INSTRUMENT	REQUIRED CHARACTERISTICS	RECOMMENDED MANUFACTURER
Digital Multimeter	DC Volts: .05% to 30V, .002% to 10V. 5-1/2 digit resolution.	Keithley Model 191
Oscilloscope	60 MHz bandwidth. 1 mV sensitivity.	Tektronix 5440/5A481/5B42
Function Generator	300 mV to 10V output. 10 kHz square wave. 10 kHz sine wave.	HP 3311A
Microwave Counter	10 MHz to 26.5 GHz range. 0.25 MHz accuracy.	EIP Model 548
RF Power Meter	10 MHz to 26.5 GHz freq. range. +13 dBm measurement capability.	HP 435A, with .01- 18 GHz 8481A Power Sensor
Spectrum Analyzer, with External Mixer	60 dB power range. 10 MHz to 40 GHz freq. range. IF output. 50 dB signal-to-noise ratio, .01 to 2 GHz.	HP 8565A, HP 11517A Mixer, HP 11519A Adapter (18-26.5 GHz), HP 11520A Adapter (26.5-40 GHz)
Modulation Meter	15 kHz bandwidth. 1 kHz sensitivity.	Marconi TF2304
True RMS Voltmeter	-60 dB sensitivity. 10 kHz bandwidth.	Fluke 8921A
Adjustable AC Line Transformer (Variac)	100/120V line voltage. 220/240V line voltage.	General Radio W5MTB, General Radio W10HM73
Line Voltage Monitor	120V line voltage. 240V line voltage.	RCA 120B RCA WV 503A
Scalar Network Analyzer	Frequency range: .01 to 26.5 GHz.	WILTRON Model 560 or 560A w/560-7S50 Opt. 2 Detector
RF Detector	Frequency range: .01 to 34 GHz.	WILTRON Model 70S50B

Table 4-1. Recommended Test Equipment for Performance Verification and Calibration (Continued)

INSTRUMENT	REQUIRED CHARACTERISTICS	RECOMMENDED MANUFACTURER
Microwave Counter	18.0 to 40 GHz range. 0.25 MHz accuracy.	EIP Model 578, with 590 Frequency Extension Kit and Option 91 Remote Sensor
RF Power Meter	18.0 to 40 GHz range. +5 dBm measurement capability.	HP 432A, with K482A and R486A Thermistor Mounts
Waveguide Attenuator	18.0 to 40 GHz range. 20 dB attenuation.	HP R382A and K382A
Directional Coupler	18.0 to 40 GHz range.	HP R752C
RF Detector	26.5 to 40 GHz range.	HP R422A
Network Analyzer Cable	Connect BNC female detector output to 560A Scalar Network Analyzer.	560A-10BX
Power Supply	0-5 Vdc.	HP 6821

Table 4-2. Reset (Default) Settings for Numeric Parameters

All Models: SWEEP TIME: 50 ms LEVEL: Maximum Leveled Power (Table 1-1) ΔF : 1000 MHz			
Model: 6609A	Model: 6621A	Model: 6629A	Model: 6637A
F1: 10 MHz	F1: 2000 MHz	F1: 8000 MHz	F1: 2000 MHz
F2: 2000 MHz	F2: 12000 MHz	F2: 18000 MHz	F2: 18000 MHz
F0: 1000 MHz	F0: 9000 MHz	F0: 13000 MHz	F0: 10000 MHz
M1: 500 MHz	M1: 3000 MHz	M1: 9000 MHz	M1: 3000 MHz
M2: 1500 MHz	M2: 11000 MHz	M2: 17000 MHz	M2: 17000 MHz
Model: 6617A	Model: 6621A-40	Model: 6629A-40	Model: 6637A-40
F1: 10 MHz	F1: 2000 MHz	F1: 8000 MHz	F1: 2000 MHz
F2: 8000 MHz	F2: 12000 MHz	F2: 18000 MHz	F2: 20000 MHz
F0: 4000 MHz	F0: 9000 MHz	F0: 13000 MHz	F0: 11000 MHz
M1: 3000 MHz	M1: 3000 MHz	M1: 9000 MHz	M1: 3000 MHz
M2: 7000 MHz	M2: 11000 MHz	M2: 17000 MHz	M2: 19000 MHz

(continued)

Table 4-2. Reset (Default) Settings for Numeric Parameters (continued)

All Models:			
SWEEP TIME: 50 ms			
LEVEL: Maximum Leveled Power (Table 1-1)			
ΔF: 1000 MHz			
Model 6638A	Model: 6647A	Model: 6653A	Model: 6659A
F1: 2000 MHz	F1: 10 MHz	F1: 2000 MHz	F1: 10 MHz
F2: 18000 MHz	F2: 18000 MHz	F2: 26000 MHz	F2: 26000 MHz
F0: 10000 MHz	F0: 10000 MHz	F0: 14000 MHz	F0: 13000 MHz
M1: 3000 MHz	M1: 1000 MHz	M1: 3000 MHz	M1: 3000 MHz
M2: 17000 MHz	M2: 17000 MHz	M2: 25000 MHz	M2: 25000 MHz
Model: 6642A	Model: 6648A		
F1: 18000 MHz	F1: 10 MHz		
F2: 40000 MHz	F2: 20000 MHz		
F0: 25000 MHz	F0: 10000 MHz		
M1: 19000 MHz	M1: 3000 MHz		
M2: 39000 MHz	M2: 19000 MHz		

b. Sweep Frequency Accuracy Tests

1. Press FREQUENCY RANGE ΔF F0.
2. Press ΔF and set for 0.050 GHz.
3. Press F0.
4. For all models other than the 6609A: In turn set F0 to the midfrequency of each applicable YIG band (5, 10, 15, and 22 GHz; or for the 6642A, 22 and 33 GHz) and verify swept-frequency accuracy, as follows:
 - (a) Press MANUAL SWEEP.
 - (b) Rotate the MANUAL SWEEP control fully counterclockwise.

- (c) Verify that the counter reads 25 MHz below the F0 frequency, with an accuracy as specified in Table 4-3.
- (d) Rotate the MANUAL SWEEP control fully clockwise.
- (e) Verify that the counter reads 25 MHz above the F0 frequency, with the accuracy specified in Table 4-3.
5. For the 6609A only:
 - (a) Set ΔF F0 to 1 GHz.
 - (b) Using steps 4a thru 4e above, verify the swept-frequency accuracy.

Table 4-3. Swept-Frequency Accuracy Specifications

FREQUENCY (MHz)	MODEL
±15	All models except 6642A, 6653A, and 6659A
±30	6653A and 6659A
±25	6642A, frequencies 26.5 GHz and below
±30	6642A, frequencies above 26.5 GHz

c. Frequency Vernier Accuracy Tests

1. Press RESET.
2. Press CW F0.
3. Record the counter's frequency read-out.
4. Press FREQUENCY VERNIER INCREASE and hold depressed until the frequency stops increasing.
5. Verify that the counter's frequency readout increased by ≥ 12 MHz (≥ 25 MHz for the 6642A, 6653A and 6659A) from the frequency recorded in step 3.
6. Press FREQUENCY VERNIER OFF.
7. Press FREQUENCY VERNIER DECREASE and hold depressed until the frequency stops decreasing.
8. Verify that the counter's frequency readout decreased by ≥ 12 MHz (≥ 25 MHz for the 6642A, 6653A, and 6659A) from the frequency recorded in step 3.

4-4 SWEEP TIME TEST

To verify the sweep generator's sweep time, perform the steps below. If the sweep time is found to be out of tolerance, perform the A2 Ramp Generator Adjustments in paragraph 5-5.

- a. Connect the test equipment as shown in Figure 4-2, and turn the equipment on.

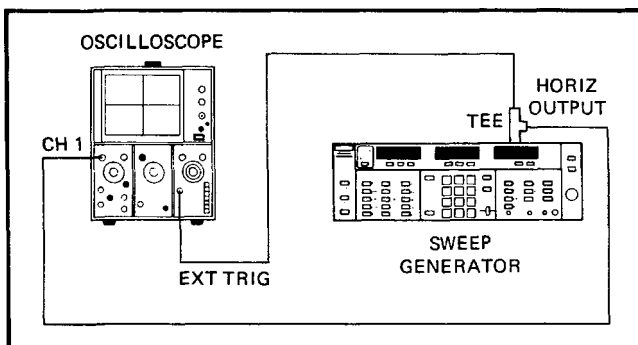

Figure 4-2. Test Equipment Setup for Sweep Time Test

- b. Press RESET on the sweep generator.
- c. Press FREQUENCY RANGE $\Delta F F_0$.
- d. Press SWEEP TIME and set for 10 ms.
- e. Verify that the oscilloscope displays a 10 ms ± 2.0 ms ramp, as shown in Figure 4-3.

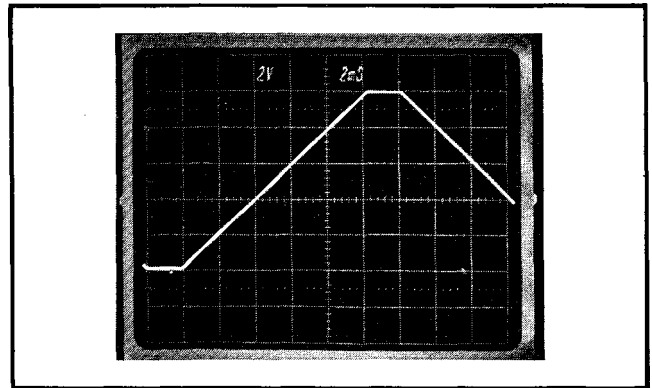

Figure 4-3. A2 Sweep Ramp, 10 ms Sweep

- f. Press SWEEP TIME and set for 1 second.
- g. Verify that the oscilloscope displays a 1 ± 0.2 second ramp, as shown in Figure 4-4.

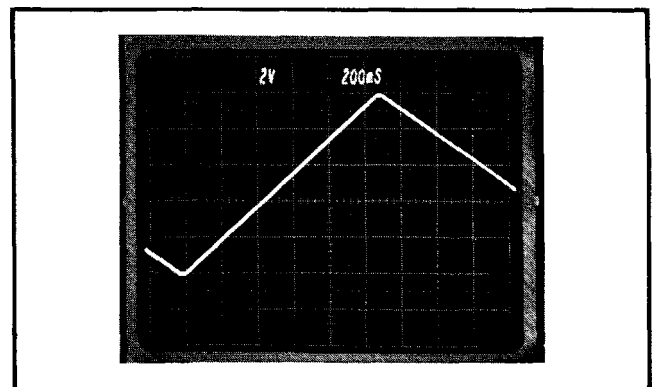

Figure 4-4. A2 Sweep Ramp, 1 s Sweep

- h. Press SWEEP TIME and set for 10 seconds.
- i. Verify that the oscilloscope displays a 10 ± 2 second ramp.

4-5 OUTPUT POWER TESTS

For all models except the 26.5 to 40 GHz band of the 6642A, verify the output power level as described below. If the output power level is found to be out of tolerance, perform the ALC Calibration adjustments in paragraph 5-14.

NOTE

The 26.5 to 40 GHz band of the 6642A is not internally leveled.

- Connect the test equipment as shown in Figure 4-5, and turn the equipment on.
- Press RESET on the sweep generator (sweeper).
- Verify that the RF SLOPE control is OFF.
- Press LEVELING - DETECTOR.
- On the network analyzer, adjust CHANNEL A OFFSET control to position the trace's minimum power point on the center graticule line; see Figure 4-6.

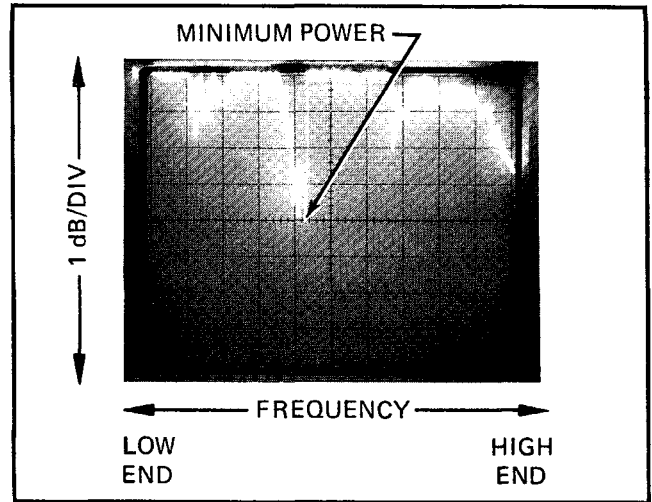

Figure 4-6. Unleveled Power

- Verify that the OFFSET dB display reads at least 0.2 dBm greater than the sweeper's output level, as indicated on the LEVEL LED display.
- On the sweeper, press LEVELING - INTERNAL.
- On the network analyzer, press CHANNEL A .5 dB PER DIVISION.

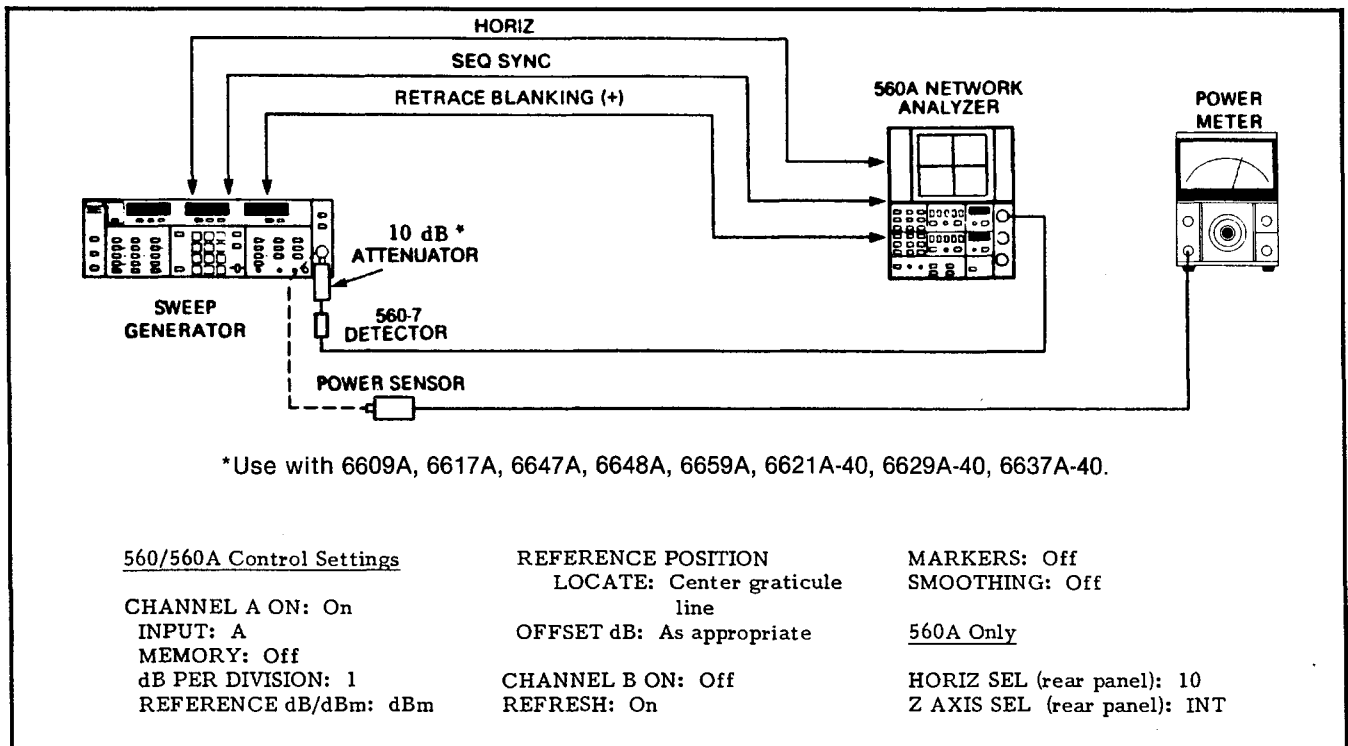

Figure 4-5. Test Equipment Setup for Output Power Tests

- i. Verify that the peak-to-peak ripple (Figure 4-7) on the network analyzer trace is as shown in Table 4-4.

Table 4-4. Power Accuracy, Peak-to-Peak Ripple

MODEL	PK-PK ACCURACY (dB)	OPT. 2 PK-PK ACCURACY (dB)
6609A	1.2	1.9
6617A	1.4	2.2
6621A	1.4	3.0
6621A-40	1.4	3.0
6629A	1.4	3.2
6629A-40	1.4	3.2
6637A	1.4	3.2
6637A-40	1.4	3.2
6638A	1.4	3.2
6642A	2.2	--
6647A	1.6	3.2
6648A	1.6	3.2
6653A	2.2	3.2
6659A	2.2	3.2

- j. Disconnect the detector from the sweeper, and connect the power sensor in its place.

NOTE

The unlevelled output power of the 6621A-40, 6629A-40, 6637A-40, and .01-2 GHz heterodyne band on applicable models may exceed +23 dBm at some frequencies. Be advised that the maximum input power level of the HP 465 Power Meter is 300 mW (+23 dBm).

- k. Press MANUAL SWEEP.

- l. On the sweeper, press CW F0 and set F0 for the midrange frequency. Example: 1 GHz (6609A), 10 GHz (6637A), 22 GHz (6642A) etc.
- m. Verify that the power meter reads the power level indicated on the sweeper's LEVEL LED display, ± 0.2 dB.
- n. For the 6653A and 6659A only:
 1. Set F0 for 23 GHz.
 2. Verify that the power meter reads the power level indicated on the sweeper's LEVEL LED display, ± 0.2 dBm.
 3. Return F0 to the midrange frequency.
- o. Press LEVEL and set the output power level first to 5 dB, then to 10 dB below the RESET power level, as indicated on the LEVEL LED display. At each setting, verify that the power meter reads the LEVEL display value, ± 0.2 dB.
- p. For the 6653A and 6659A only:
 1. Set F0 for 23 GHz.
 2. Repeat step o. above.
 3. Return F0 to midrange frequency.
- q. For all models except the 6642A, press F0 and set for the high-end frequency.

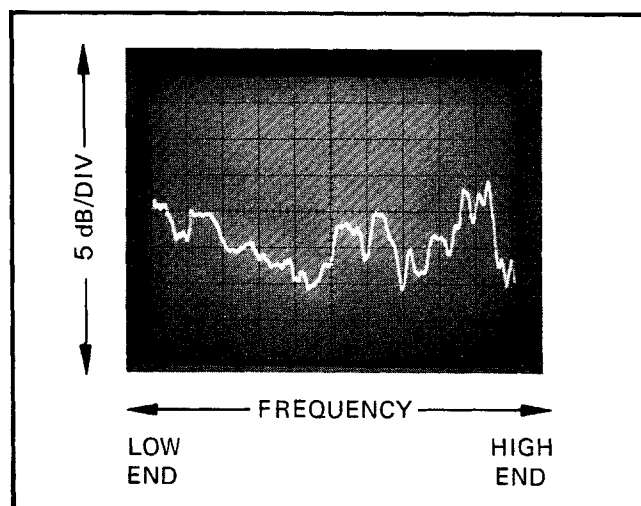

Figure 4-7. Leveled Power

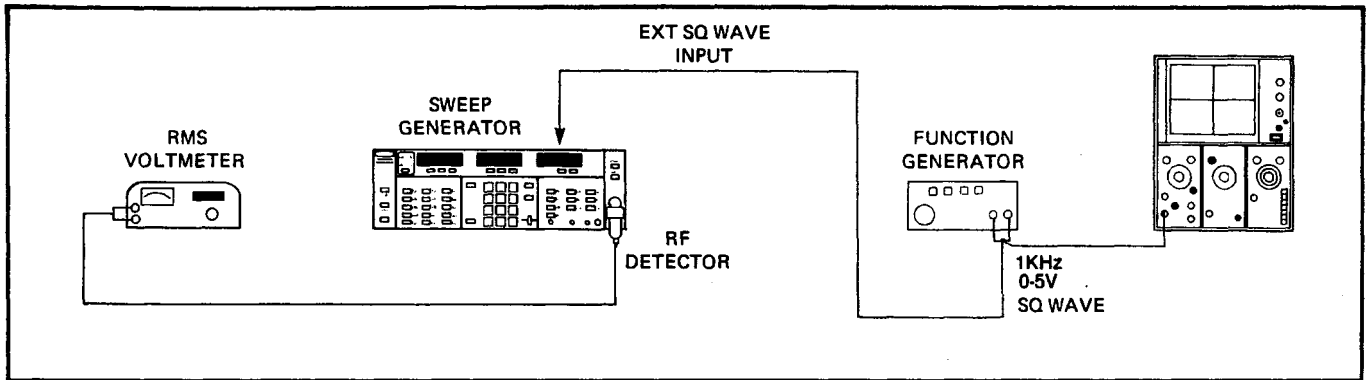

Figure 4-8. Test Equipment Setup for Residual AM Test

- r. Record power meter reading.
- s. Rotate RF SLOPE fully clockwise.
- t. Verify that the power meter reading increases by ≈ 3 dB.
- u. Return RF SLOPE to OFF.
- a. Connect the test equipment as shown in Figure 4-8, and turn the equipment on.
- b. Press RESET on the sweep generator (sweeper).
- c. Press CW F1 and set to the midrange frequency.

4-6 RESIDUAL AM TEST

To verify that the residual amplitude modulation signals in the sweep generator are tolerable, perform the steps below. If the residual AM is found to be out of tolerance, contact WILTRON Customer Service.

- d. Record the RMS voltmeter reading.
- e. Turn the function generator off.
- f. Record the second RMS voltmeter reading.

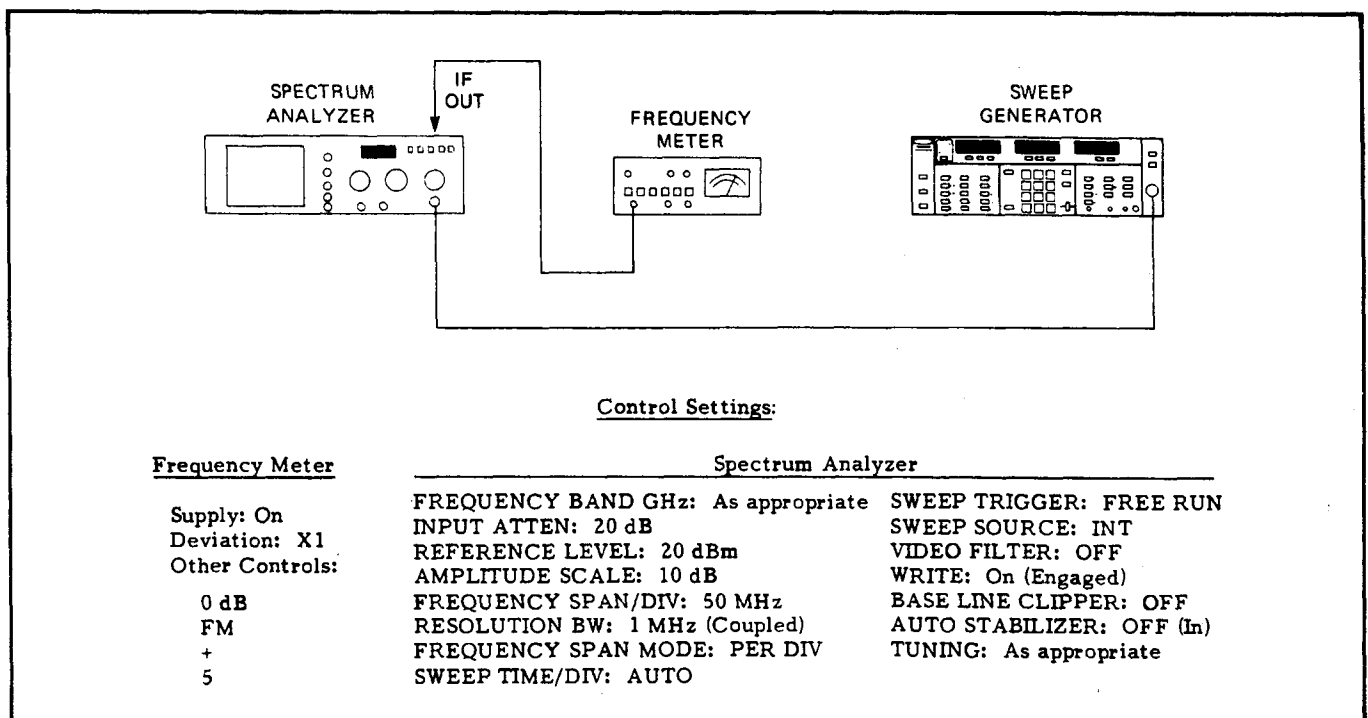

Figure 4-9. Test Equipment Setup for Residual FM Test, .01 to 20 GHz

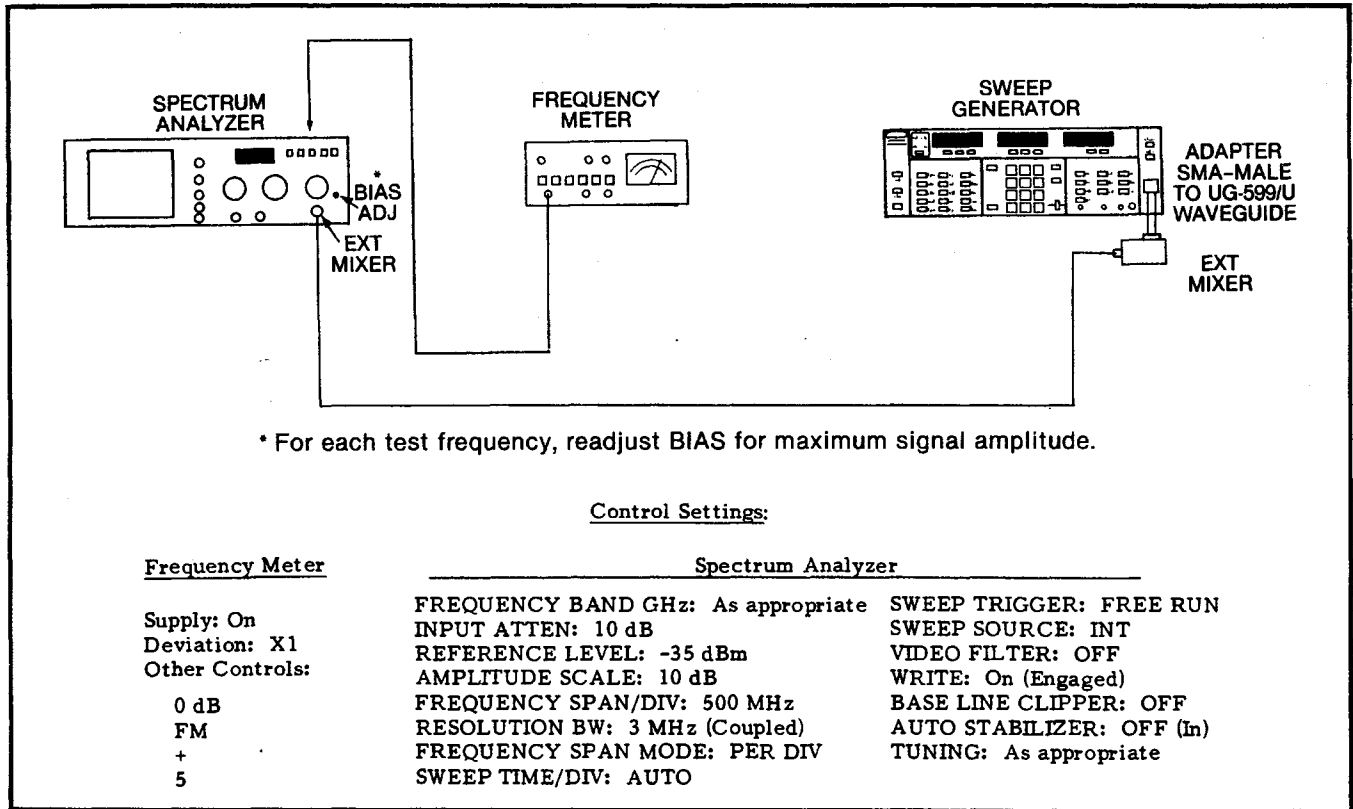

Figure 4-10. Test Equipment Setup for Residual FM Test, 18 to 26.5 GHz

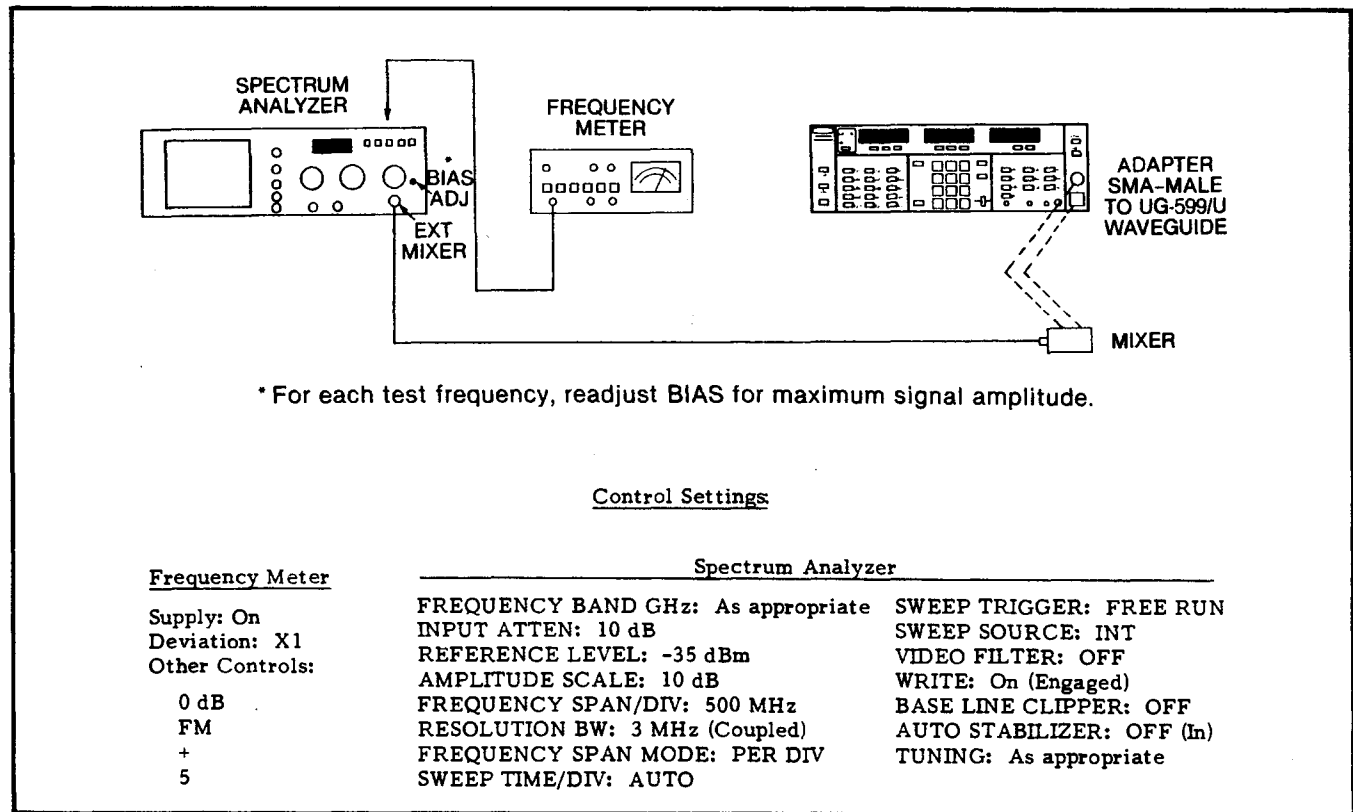

Figure 4-11. Test Equipment Setup for Residual FM Test, 18 to 40 GHz

g. Calculate the sweeper's residual AM per the following formula:

$$\text{Residual AM (-dBc)}^* = - \left[\left| \begin{array}{c} \text{step d} \\ \text{reading} \end{array} \right| + \left| \begin{array}{c} \text{step f} \\ \text{reading} \end{array} \right| + 9 \text{ dB} \right].$$

* dB below the carrier.

h. Residual AM should be less than -50 dBc.

i. Turn the function generator back on.

j. Repeat steps c. thru h. for the midfrequency in each applicable frequency band (1 GHz (Het. Band); 5 GHz (YIG 1 Band); 10 GHz (YIG 2 Band); 15 GHz (YIG 3 Band); 22.25 GHz (YIG 4 Band); or for 6642A, 22.25 GHz (YIG 1 Band) and 33.25 GHz (YIG 2 Band)).

4-7 RESIDUAL FM TEST

To verify that the residual frequency modulation signals in the sweep generator are tolerable, perform the steps below. If the residual FM is found to be out of tolerance, contact WILTRON Customer Service.

a. Connect the test equipment as shown in Figure 4-9, 4-10, or 4-11 as applicable.

b. Using the following procedure, check residual FM at each applicable frequency in Table 4-5.

1. On the sweep generator (sweeper), press CW F0 and set for the desired frequency.

2. On the spectrum analyzer:

(a) Adjust TUNING to center the sweeper's output frequency on the CENTER FREQUENCY graticule line.

(b) Adjust REFERENCE LEVEL to place the top of the waveform on the REFERENCE LEVEL graticule line.

(c) Observe the display; it should resemble Figure 4-12.

(d) Press ZERO SPAN and readjust TUNING to place the trace on the REFERENCE LEVEL graticule line (Figure 4-13).

Table 4-5. Residual FM Test Frequencies

FREQUENCY (GHz)	MODEL
.05	6609A, 6617A, 6647A, 6648A, 6659A
1.8	Same as above.
7.8	6617A, 6621A, 6621A-40, 6637A, 6637A-40, 6638A, 6647A, 6648A, 6653A, 6659A
12.2	6621A, 6621A-40, 6629A, 6629A-40, 6637A, 6637A-40, 6638A, 6647A, 6648A, 6653A, 6659A
17.8	6653A, 6659A
18.6	6629A, 6629A-40, 6637A, 6637A-40, 6638A, 6642A, 6647A, 6648A
20	6638A, 6648A
26.5	6642A, 6653A, 6659A
40	6642A

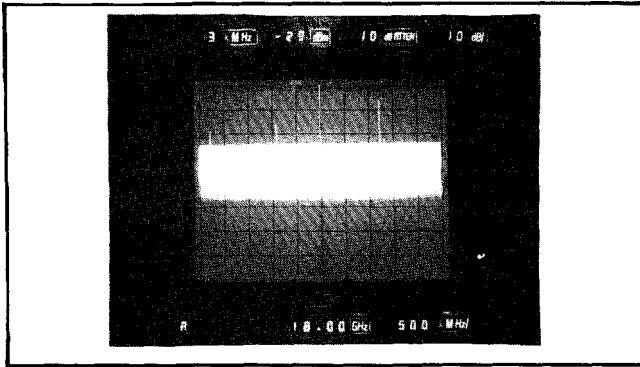

Figure 4-12. Sweeper's Frequency At 500 MHz/Division FREQUENCY SPAN

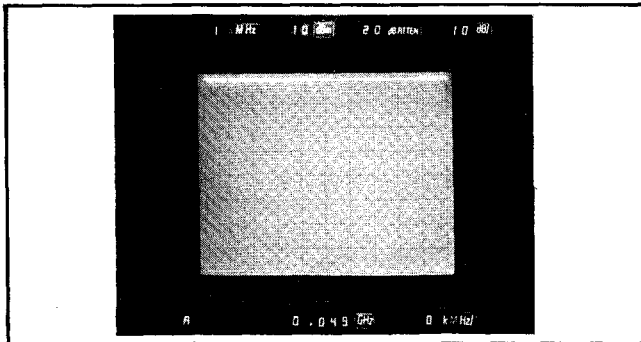

Figure 4-13. Spectrum Analyzer ZERO SPAN Display

- (e) Position AUTO STABILIZER to ON; if necessary, readjust the TUNING control to place the

trace on the REFERENCE LEVEL graticule line.

3. On the modulation meter, after ensuring the HIGH and LOW indicators are not lit, read the frequency deviation meter. The meter should indicate as shown in Table 4-6.

NOTE

Increase REFERENCE LEVEL setting as necessary to ensure that LOW LEVEL indicator goes out.

4-8 EXTERNAL FM AND PHASE-LOCK TEST

To verify that the sweep generator provides the correct -6 MHz/V frequency deviation for an input FM or phase-lock signal, perform the steps below. If the FM Sensitivity specification is found to be out of tolerance, contact WILTRON Customer Service.

- a. Set up the test equipment as shown in Figure 4-14 and turn the equipment on.
- b. Adjust the power supply for a DVM reading of -4V ±0.04 volts.

Table 4-6. Residual FM Specifications

MODEL	SPECIFICATION (kHz) (30 Hz to 15 kHz BW)
6609A, 6617A	7
6621A, 6621A-40, 6629A, 6629A-40	10
6637A, 6637A-40, 6638A, 6647A, 6648A	7, below 8 GHz 10, below 8 GHz
6653A, 6659A	7, below 8 GHz 10, 8 to 18 GHz 15, above 18 GHz
6642A	30, below 26.5 GHz 40, above 26.5 GHz

- c. On the sweep generator:
 1. Press RESET.
 2. Press CW F0.
 3. Press and hold the appropriate FREQUENCY VERNIER pushbutton until the counter reads the F0 frequency ± 100 kHz (± 200 kHz for the 6642A, 6653A, or 6659A).
 4. Press FM AND PHASELOCK.
- d. Verify that the counter's frequency readout increased by 24 ± 2.4 MHz.
- e. Readjust the power supply for a DVM reading of $+4 \pm 0.04$ volts.
- f. Verify that the counter's frequency readout decreased by 24 ± 2.4 MHz.

4-9 RF OUTPUT SIGNAL TESTS, ALL MODELS EXCEPT 6642A, 6653A, AND 6659A

To verify that the sweep generator's RF output signal meets the harmonic, spurious, purity, and frequency-pulling specifications,

perform the steps in subparagraphs a. thru d. below. If any of the output-signal tests are found to be out of tolerance, contact WILTRON Customer Service.

a. 2nd Harmonic Attenuation Tests

1. Connect the test equipment as shown in Figure 4-15 and turn the equipment on.
2. On the sweep generator (sweeper):
 - (a) Press SHIFT then CW RAMP to off (rear panel HORIZ OUTPUT DURING CW switch to OFF for 6600 models).
 - (b) Press RESET.
 - (c) Press CW F1.
3. On the spectrum analyzer, adjust TUNING to position the sweeper's fundamental frequency near the CENTER FREQUENCY graticule line.
4. While observing the spectrum analyzer's display,

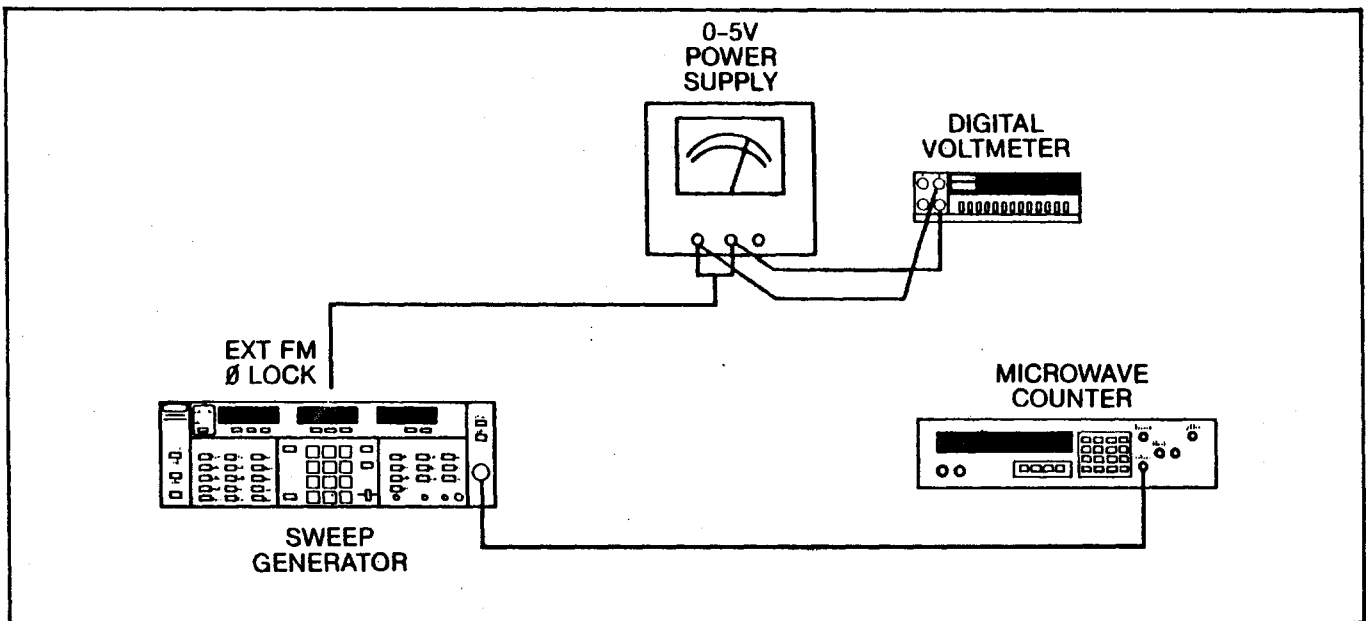

Figure 4-14. Test Equipment Setup for FM Deviation Test

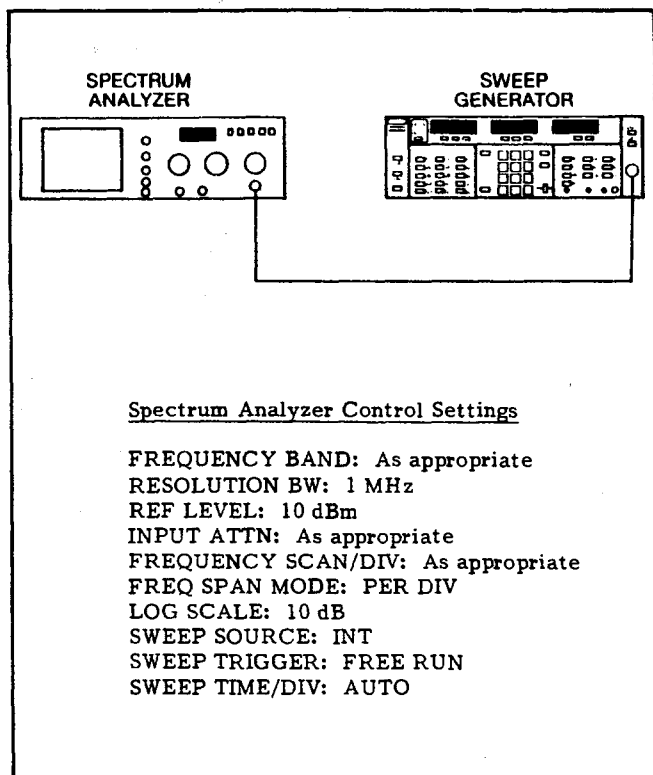

Figure 4-15. Test Equipment Setup for RF Output Signal Tests

- (a) move the sweeper's INCREASE/DECREASE lever toward INCREASE, so that the displayed signals move slowly upward in frequency, and
- (b) at the same time, adjust the spectrum analyzer's TUNING control clockwise to keep the 2nd harmonic on screen.

NOTE

Change the spectrum analyzer's FREQUENCY RANGE setting as necessary in order to observe the sweep generator's entire frequency range.

5. Verify that the applicable 2nd harmonic is attenuated as shown below, except for the 6621A40, 6629A-40, and 6637A-40. For these models, the 2nd harmonic is attenuated to -25 dBc..

FREQUENCY	ATTENUATION
.01 - 2 GHz	-30 dBc
2 - 20 GHz	-40 dBc

b. Spurious Signal Test

1. On the sweeper, move the INCREASE/DECREASE lever to maximum DECREASE, and return F1 to the low-end frequency.
2. On the spectrum analyzer:
 - (a) Press FREQUENCY BAND as appropriate to display low-end frequency.
 - (b) Adjust TUNING for the sweeper's low-end frequency.
3. While observing the spectrum analyzer for non-harmonically-related (spurious) signals, move the sweeper's INCREASE/DECREASE lever toward INCREASE.
4. Verify that spurious signals, if present, are <-40 dBc for the .01-2 GHz band and <-60 dBc for the remaining 2 to 18.6 (or 20) GHz frequency range.

NOTE

Spurious signals may be generally characterized as follows: They will (1) be weak in power, (2) "pop up" abruptly and track oppositely to the fundamental and harmonic signals, and (3) disappear abruptly. An example of a spurious response at 984 MHz is shown in Figure 4-16.

c. Signal Purity Test

1. On the sweeper, press CW F1 and set

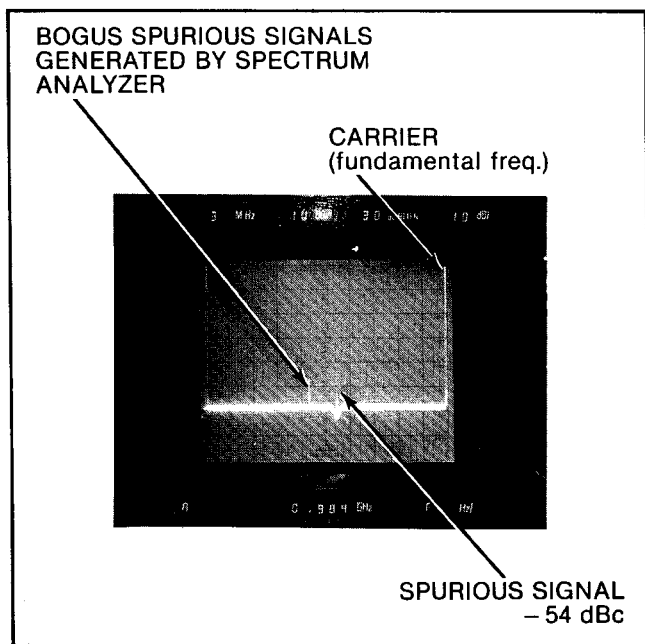

Figure 4-16. Example of a Spurious Signal

for 0.050 GHz (6609A); 8.050 GHz (6629A/6629A-40); or 2.050 GHz (all other models).

2. On the spectrum analyzer:
 - (a) Press FREQUENCY BAND as appropriate to display the step 1. frequency.
 - (b) Adjust FREQUENCY SPAN/DIV for 100 kHz (coupled).
 - (c) Adjust TUNING to center the sweeper's fundamental frequency on the CENTER FREQUENCY graticule line, as shown in Figure 4-17.
 - (d) Set VIDEO FILTER to .03.
3. Verify that the noise sidebands located 100 kHz away from the sweeper's fundamental frequency are <-60 dBc.
4. Repeat the Signal Purity Test for the following frequencies, as applicable:
 - (a) 8.05 GHz
 - (b) 12.35 GHz

- (c) 12.45 GHz
- (d) 18.6 GHz
- (e) 20.0 GHz

d. Frequency Pulling Test

1. On the sweeper:
 - (a) Press CW F0 and set for 0.050 GHz (6609A), 8.050 GHz (6629A/6629A-40), or 2.050 GHz (all other models).
 - (b) Press LEVEL and set as shown below:

Model	Power Level (dBm)
6609A	+13
6621A-40, 6629A-40, 6637A-40	+16
All Others	+10

2. On the spectrum analyzer,
 - (a) press FREQUENCY BAND as appropriate to display the step 1(a) frequency;
 - (b) adjust FREQUENCY SPAN/DIV to 100 kHz (coupled);
 - (c) adjust TUNING to center the sweeper's fundamental frequency on the CENTER FREQUENCY graticule line.

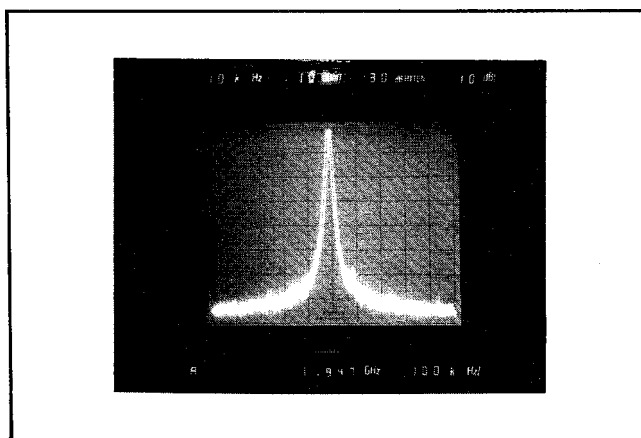

Figure 4-17. Noise Sidebands

3. On the sweeper, press LEVEL and set as shown below:

Model	Power Level (dBm)
6609A	+3
6621A-40, 6629A-40, 6637A-40	+6
All Others	0

4. On the spectrum analyzer, verify that the displayed signal moved less than ± 500 kHz.

NOTE

The waveform photograph in Figure 4-18 shows a representative frequency shift. The photograph is a double exposure: the first exposure is the signal at 10 dBm and the second is the same signal at 0 dBm.

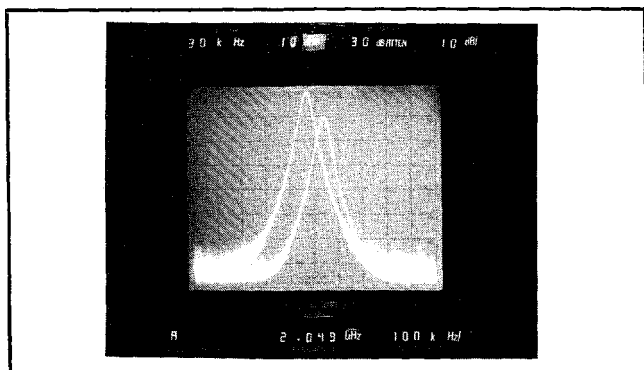

Figure 4-18. Example of Frequency Pulling

5. Repeat the Frequency Pulling test for the following frequencies, as applicable:
 - (a) 8.05 GHz
 - (b) 12.35 GHz
 - (c) 12.45 GHz
 - (d) 18.6 GHz
 - (e) 20.0 GHz

4-10 RF OUTPUT SIGNAL TESTS, MODEL 6642A

To test the sweep generator's RF output for (1) spurious signals, (2) signal purity 100 kHz above and below the carrier frequency, and (3) frequency pulling with a 10 dB power level change, perform the steps in subparagraphs a. thru c. below. If these tests indicate that the output signal is not within either the -60 dBc spurious or signal purity specification or the ± 500 kHz frequency pulling specification, contact WILTRON Customer Service.

a. Spurious Signal Test

1. Connect the test equipment and position the controls as shown in Figure 4-19; turn the equipment on.
2. On the sweep generator (sweeper):
 - (a) Press SHIFT then CW RAMP (set rear panel HORIZ ON DURING CW to OFF for 6600 models).
 - (b) Press RESET.
 - (c) Press CW F1.
3. On the spectrum analyzer:
 - (a) Adjust TUNING to position the sweeper's frequency on the CENTER FREQUENCY graticule line.
 - (b) Adjust EXT MIXER BIAS for maximum signal amplitude.
 - (c) Adjust REFERENCE LEVEL to place the top of the waveform on the REFERENCE LEVEL graticule line.
 - (d) The display should resemble Figure 4-20.
4. On the sweeper, press F1.
5. While observing the analyzer and operating the TUNING control to keep the sweeper's frequency on screen, operate the sweeper's IN-

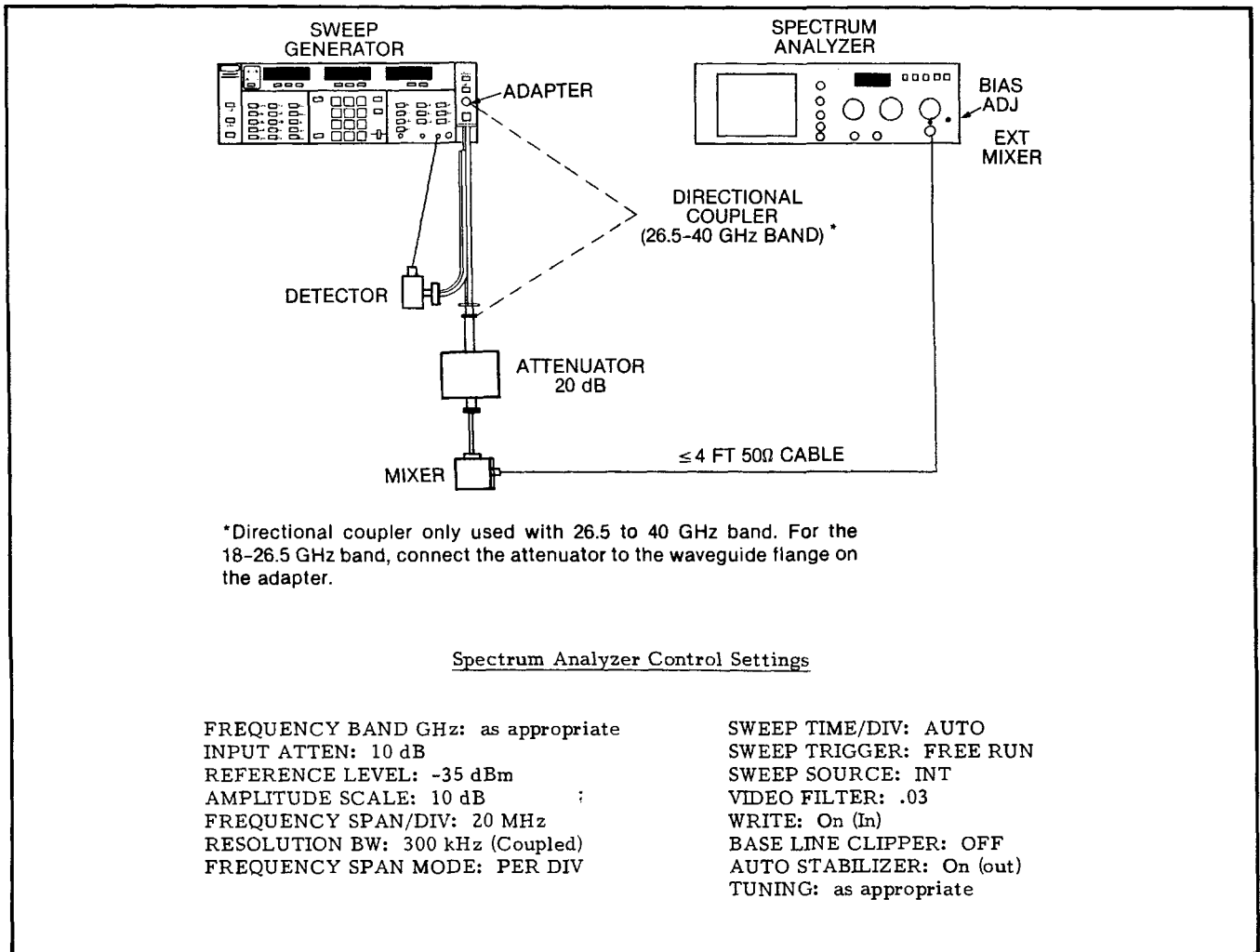

Figure 4-19. Test Equipment Setup for RF Output Tests

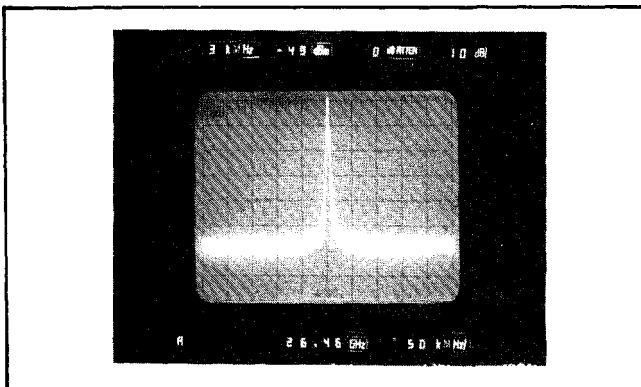

Figure 4-20. Analyzer Display, with 30 dB Signal-to-Noise Ratio

CREASE/DECREASE lever to slowly increase frequency to 26.5 GHz.

NOTE

Readjust EXT MIXER BIAS

for peak signal amplitude each 500 MHz.

6. Ensure that no bonified spurious signals (that is, signals that pass the analyzer's SIG IDENT test) are present.
7. Remove the attenuator/mixer combination from the 18-26.5 GHz connector, and connect it to the directional coupler as shown in Figure 4-19.
8. On the sweeper, press LEVELING-DETECTOR and adjust EXT ALC GAIN to midrange.

9. Repeat steps 5 and 6 above for the 26.5 to 40 GHz band.

b. Signal Purity Test

1. Remove the attenuator/mixer combination from the directional coupler, and return it to the 18-26.5 GHz connector.

2. On the sweeper, operate the INCREASE/DECREASE lever to place the F1 frequency at 18 GHz.

3. On the spectrum analyzer:

- (a) Adjust FREQUENCY SPAN for 5 MHz per division.

- (b) Adjust TUNING to center the sweeper's frequency on the CENTER FREQUENCY graticule line.

- (c) Readjust FREQUENCY SPAN for 50 kHz per division. Move the control in incremental steps, and readjust TUNING control as necessary to keep the signal centered on the display.

- (d) Rapidly (so as to capture the signal while it is still in the center of the screen), perform the following steps:

- (1) rotate PERSIST fully clockwise;
- (2) press SWEEP TRIGGER-SINGLE;
- (3) press ERASE;
- (4) press SWEEP TRIGGER-START/RESTART;
- (5) press STORE.

4. A trace similar to the one shown in Figure 4-21 should be obtained. Ensure that no sidebands are present 100 kHz (2 divisions) on either side of the carrier frequency.

5. On the spectrum analyzer,

- (a) press WRITE;

- (b) rotate PERSIST fully counter-clockwise;

- (c) press FREE RUN.

6. On the sweeper, set F1 for 26 GHz and repeat step 2.

7. Remove the attenuator/mixer combination from the 18-26.5 GHz connector, and reconnect it to the directional coupler.

8. Repeat steps 3 thru 5 at 26.5 and 40 GHz.

c. Frequency Pulling Test

1. Remove the attenuator/mixer combination from the directional coupler, and return it to the 18-26.5 GHz connector.

2. On the sweeper, press CW F1 and set for 18 GHz.

3. On the spectrum analyzer:

- (a) Rotate VIDEO FILTER to OFF.

- (b) Adjust FREQUENCY SPAN TO 100 kHz.

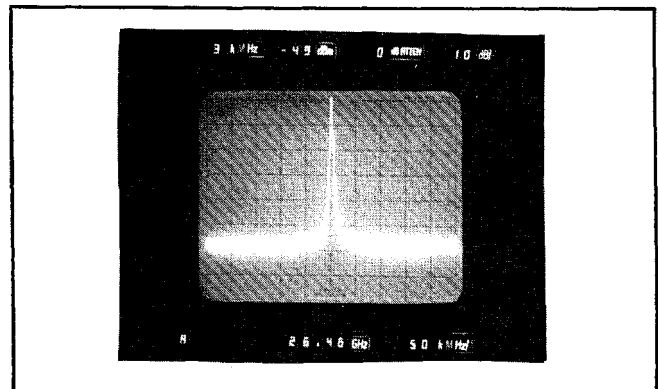

Figure 4-21. Noise Sidebands (6642A)

- (c) Adjust TUNING to center the sweeper's frequency on the display.
- 4. On the sweeper, press LEVEL and set for -5 dBm.
- 5. Ensure that the sweeper's frequency did not shift more than ± 500 kHz.
- 6. Remove the attenuator/mixer combination from the 18-26.5 GHz connector, and reconnect it to the directional coupler.
- 7. On the sweeper, press CW F1 and set for 27 GHz.
- 8. On the analyzer, readjust TUNING to center the sweeper's frequency on the display.
- 9. On the sweeper, press LEVEL and set for -10 dBm.

NOTE

For the 26.5 to 40 GHz band the LEVEL LED readout does not indicate actual power unless the power level has been calibrated using a power meter. However, a reduction of 10 dB from the power level indicated on the LEVEL readout will result in an approximate 10 dB reduction in power, which can be verified on the spectrum analyzer.

- 10. Ensure that the sweeper's frequency did not shift more than ± 500 kHz.

4-11 RF OUTPUT SIGNAL TESTS, MODELS 6653A AND 6659A

To verify that the sweep generator's RF output signal meets the harmonic, spurious, purity, and frequency-pulling specifications, perform the steps in subparagraphs a. thru d. below. If any of the output-signal tests are found to be out of tolerance, contact WILTRON Customer Service.

a. 2nd Harmonic Attenuation Tests

- 1. Connect test equipment as shown in Figure 4-22 and turn the equipment on.
- 2. On the sweep generator (sweeper):
 - (a) Press SHIFT then CW RAMP to off (set rear panel HORIZ OUTPUT DURING CW to OFF for 6600 models).
 - (b) Press RESET.
 - (c) Press CW F1.
- 3. On the spectrum analyzer, adjust TUNING to position the sweeper's fundamental frequency near the CENTER FREQUENCY graticule line.
- 4. While observing the spectrum analyzer's display,
 - (a) move the sweeper's INCREASE/DECREASE lever toward INCREASE, so that the displayed signals move slowly upward in frequency, and
 - (b) at the same time, adjust the spectrum analyzer's TUNING control clockwise to keep the 2nd harmonic on screen.

NOTE

Change the spectrum analyzer's FREQUENCY RANGE setting as necessary in order to observe the sweep generator's entire frequency range.

- 5. Stop frequency tuning at 20 GHz (6653A/6659A).
- 6. Verify that the applicable 2nd harmonic is attenuated as shown below.

FREQUENCY	ATTENUATION
.01 - 2 GHz	-30 dBc
2 - 26.5 GHz	-40 dBc

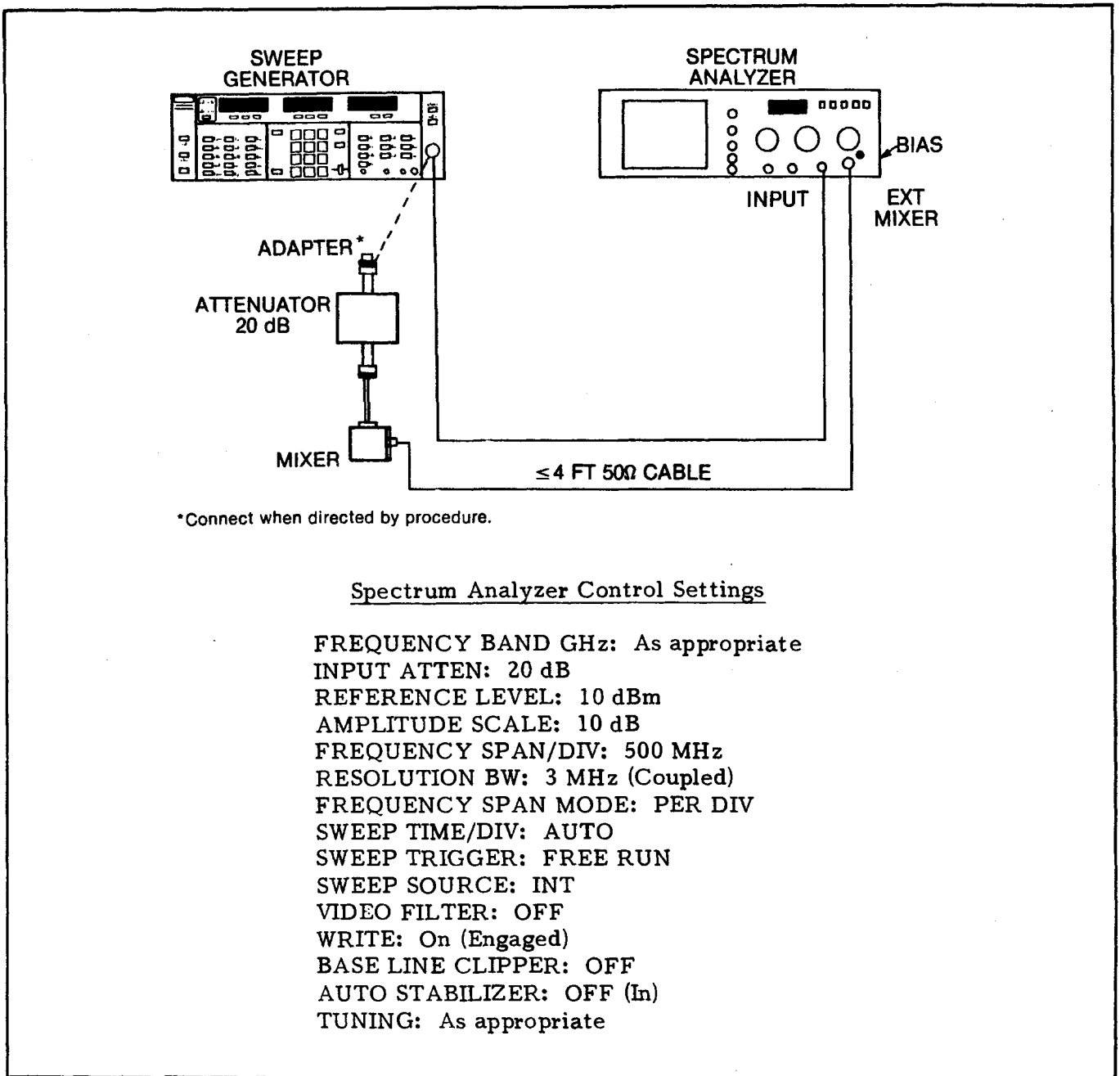

Figure 4-22. Test Equipment Setup for RF Output Tests, Models 6653A and 6659A

b. Spurious Signal Test

1. On the sweeper, move the INCREASE/DECREASE lever to maximum DECREASE, and return F1 to the low-end frequency.

2. On the spectrum analyzer:

- (a) Press FREQUENCY BAND .01-1.8 GHz (or 1.7-4.1 GHz).
- (b) Adjust TUNING for sweeper's low-end frequency.
3. While observing the spectrum analyzer for non-harmonically-related (spurious) signals, move the

sweeper's INCREASE/DECREASE lever toward INCREASE.

4. Verify that spurious signals, if present, are <-40 dBc for the .01-2 GHz band, and <-60 dBc for the remaining 2 to 18.0 GHz frequency range.

NOTE

Spurious signals may be generally characterized as follows: they will (1) be weak in power, (2) "pop up" abruptly and track oppositely to the fundamental and harmonic signals, and (3) disappear abruptly. An example of a spurious response at 984 MHz is shown in Figure 4-23.

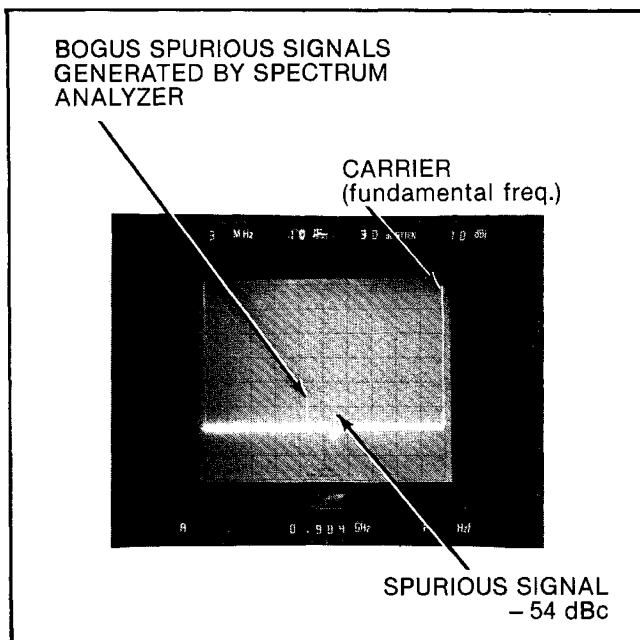

Figure 4-23. Example of a Spurious Signal

5. Remove the cable from the RF OUTPUT connector, and connect the attenuator/mixer combination in its place.
6. On the spectrum analyzer:
 - (a) Adjust TUNING to position the sweeper's frequency on the CENTER FREQUENCY graticule line.

- (b) Adjust EXT MIXER BIAS for maximum signal amplitude.
- (c) Adjust REFERENCE LEVEL to place the top of the waveform on the REFERENCE LEVEL graticule line.
- (d) The display should resemble Figure 4-24.

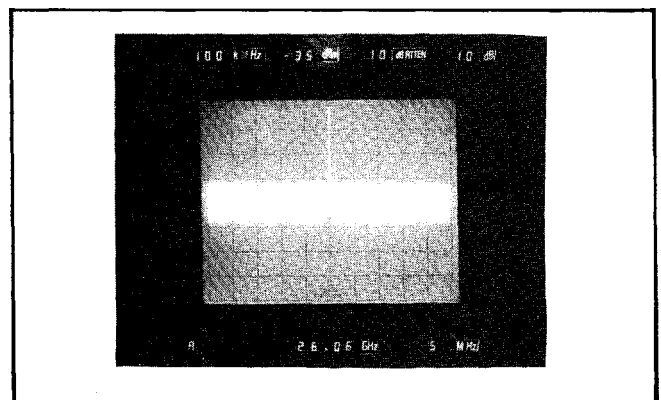

Figure 4-24. Analyzer Display, With 30 dB Signal-To-Noise Ratio

7. On the sweeper, press F1.
8. While observing the analyzer and operating the TUNING control to keep the sweeper's frequency on the screen, operate the sweeper's INCREASE/DECREASE lever to slowly increase the frequency to 26.5 GHz.

NOTE

Readjust EXT MIXER BIAS for peak signal amplitude each 500 MHz.

9. Ensure no bonified spurious signals (that is, signals that pass the analyzer's SIG IDENT test) are present.

c. Signal Purity Test

1. Remove the attenuator/mixer combi-

nation from the RF OUTPUT connector, and replace it with the test cable.

2. On the sweeper, press CW F1 and set for 2.050 GHz.

3. On the spectrum analyzer:

(a) Press FREQUENCY BAND 1.7-4.1 GHz.

(b) Adjust FREQUENCY SPAN/DIV for 100 kHz.

(c) Adjust RESOLUTION BW for 10 kHz.

(d) Adjust TUNING to center the sweeper's fundamental frequency on the CENTER FREQUENCY graticule line, as shown in Figure 4-25.

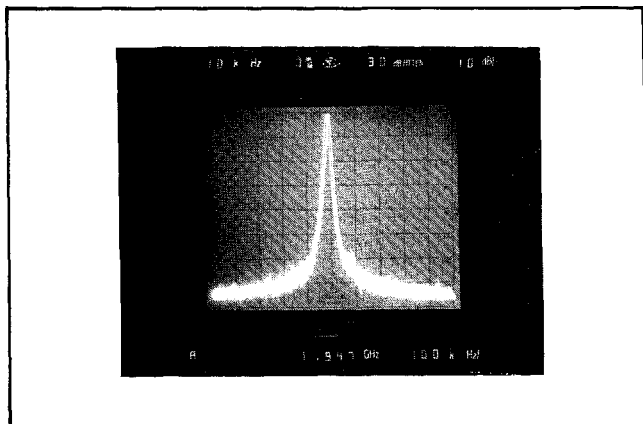

Figure 4-25. Noise Sidebands (≤ 18 GHz)

(e) Adjust VIDEO FILTER to .03.

4. Verify that the noise sidebands located 100 kHz away from the sweeper's fundamental frequency are < -60 dBc.

5. Repeat the Signal Purity Test for the following frequencies:

(a) 8.05 GHz

(b) 12.35 GHz

(c) 12.45 GHz

(d) 18.0 GHz

6. Remove the test cable from the RF OUTPUT connector, and replace it with the attenuator/mixer combination.

7. On the sweeper, operate the INCREASE/DECREASE lever to place the F1 frequency at 26.0 GHz.

8. On the spectrum analyzer:

(a) Adjust FREQUENCY SPAN for 5 MHz.

(b) Adjust TUNING to center the sweeper's frequency on the CENTER FREQUENCY graticule line.

(c) Readjust FREQUENCY SPAN for 50 kHz. Move the control in incremental steps, and readjust TUNING as necessary to keep the signal centered on the display.

(d) Rapidly (so as to capture the signal while it is still in the center of the screen), perform the following steps:

(1) rotate PERSIST fully clockwise;

(2) press SWEEP TRIGGER-SINGLE.

(3) press ERASE;

(4) press SWEEP TRIGGER-START/RESTART;

(5) press STORE.

9. A trace similar to the one shown in Figure 4-26 should be obtained. Ensure that no sidebands are present 100 kHz (2 division) on either side of the carrier frequency.

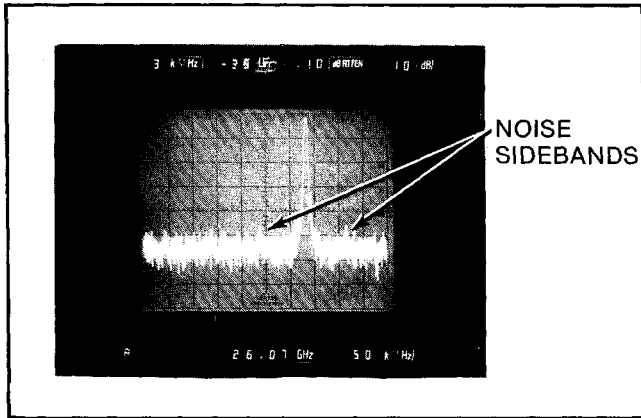

Figure 4-26. Noise Sidebands (>18.0 GHz)

10. On the analyzer:
 - (a) Press WRITE.
 - (b) Rotate PERSIST fully counterclockwise.
 - (c) Press FREE RUN.
 11. On the sweeper, press CW F2 and repeat step 8.
- d. Frequency Pulling Test
1. Remove the attenuator/mixer combination from the RF OUTPUT connector, and replace it with the test cable.
 2. On the sweeper:
 - (a) Press CW F0 and set for 2.050 GHz.
 - (b) Press LEVEL and set for +10 dBm.
 3. On the spectrum analyzer:
 - (a) Press FREQUENCY BAND 1.7-4.1 GHz.
 - (b) Adjust FREQUENCY SPAN/DIV to 100 kHz.
 - (c) Adjust RESOLUTION BW for 30 kHz.

- (d) Adjust TUNING to center the sweeper's fundamental frequency on the CENTER FREQUENCY graticule line.

4. On the sweeper, press LEVEL and set for 0 dBm.
5. On the spectrum analyzer, verify that the displayed signal moves less than ± 500 kHz.

NOTE

The waveform photograph in Figure 4-27 shows a representative frequency shift. The photograph is a double exposure: the first exposure is the signal at 100 dBm and the second is the same signal at 0 dBm.

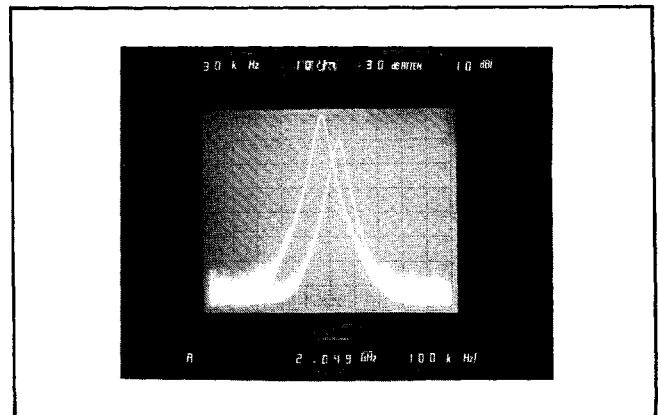

Figure 4-27. Example of Frequency Pulling

6. Repeat the Frequency Pulling test for the following frequencies:
 - (a) 8.05 GHz
 - (b) 12.35 GHz
 - (c) 12.45 GHz
 - (d) 18.0 GHz
7. Remove the test cable from the RF OUTPUT connector, and replace it with the attenuator/mixer combination.

8. On the spectrum analyzer:

- (a) Rotate VIDEO FILTER to OFF.
- (b) Adjust FREQUENCY SPAN TO 100 kHz.
- (c) Adjust TUNING to center the

sweeper's frequency on the display.

- 9. On the sweeper, press LEVEL and set for -6 dBm.
- 10. Ensure that the sweeper's frequency did not shift more than ± 500 kHz.

SECTION V

CALIBRATION AND ADJUSTMENTS

5-1 INTRODUCTION

This section contains adjustment and calibration instructions, and is organized as follows:

Para.	Adjustment or Calibration
5-4	Power Supply
5-5	A2 Ramp Generator
5-6	A5 Frequency Instruction
5-7	A3 Marker Generator
5-8	A6-A9 YIG Driver
5-9	Frequency Calibration
5-10	Tracking Filter
5-11	Sweep Rate Compensation
5-12	ALC Loop Calibration

5-2 RECOMMENDED TEST EQUIPMENT

The test equipment recommended for calibration of the sweep generator is listed in Table 4-1.

5-3 ADJUSTMENTS FOLLOWING PCB OR COMPONENT REPAIR OR REPLACEMENT

Table 5-1 lists the adjustments that should be performed following the repair or replacement of PCBs and components.

5-4 POWER SUPPLY ADJUSTMENTS

This paragraph provides instructions for adjusting the +5V and -38V supplies and the OUT OF REG, HIGH LINE, and LOW LINE motherboard LEDs. These adjustments should be performed when (1) power supply troubles are suspected and (2) after maintenance on any of the A13/A14 power supply circuits has been performed. The test equipment setup for the adjustments in subparagraphs d. and e. is shown in Figure 5-1.

a. +5 Volt Adjustment

1. Remove the top, bottom, and right-side covers. Refer to paragraph 7-3.1 for instructions, if necessary.



If maintenance has been performed on the A13/A14 power supply, perform steps 2 thru 8; otherwise, proceed to step 9.

2. Remove the A1 (Option 3) and A2 thru A10 PCBs (Figure 5-2).

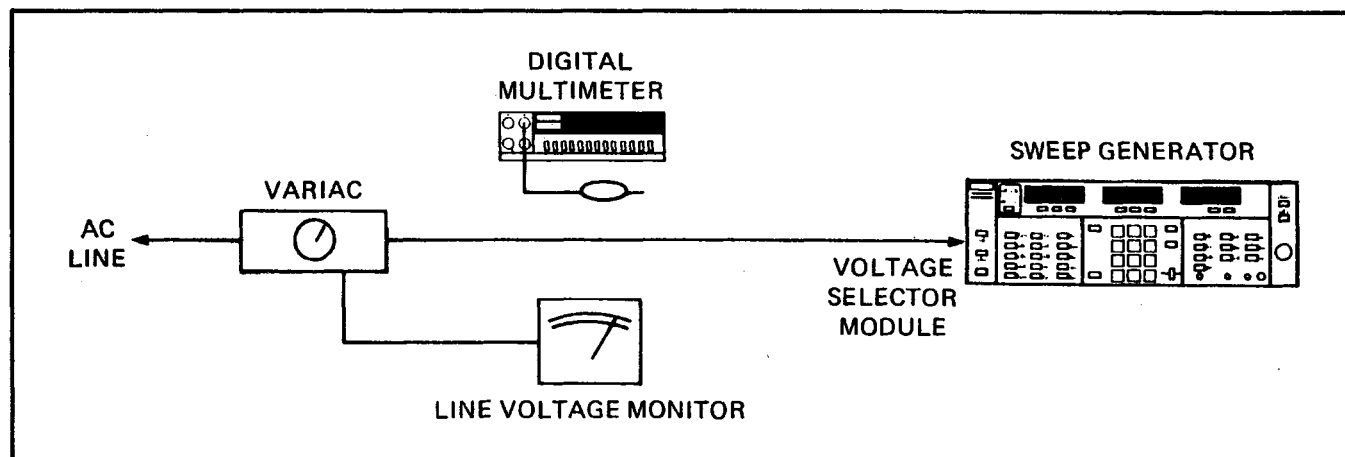

Figure 5-1. Test Equipment Setup for Low- and High-Line Adjustments

Table 5-1. Recommended Adjustments Following Repair Actions

IF A REPAIR OR REPLACEMENT ACTION WAS MADE TO:	PERFORM THE FOLLOWING ADJUSTMENTS IN PARAGRAPH(S):
<p>A1 PCB A2 PCB A3 PCB A4 PCB A5 PCB A6 PCB</p>	<p>None 5-5 thru 5-12 5-7 5-12 5-6 & 5-9 thru 5-12 5-6 thru 5-12</p>
<p>CAUTION</p> <p>After performing maintenance on the A6-A9 PCBs or installing a replacement YIG, check the bias before applying power to the YIG. Refer to paragraph 5-8.2.</p>	
<p>A7 PCB A8 PCB A10 PCB A11 PCB A12 PCB A13/A14 PCBs Osc 1 YIG Osc 2 YIG Osc 3 YIG</p>	<p>5-6 thru 5-12 5-6 thru 5-12 5-6 & 5-9 thru 5-12 None None 5-4 thru 5-12 Same as for the A6 PCB. Same as for the A7 PCB. Same as for the A8 PCB.</p>
<p>PIN Switch, Coupler, or Down Converter</p>	<p>A4 Log Amplifier. (This adjustment requires specialized test equipment, available only at the factory.)</p>

3. As applicable, disconnect the following A14 connectors (Figure 5-2): P5, P6, P7, P12, P13, P14, P16, P17, P20, P23, P27, and P30.
4. Clip a 1/2W fixed resistor, 50 to 100Ω, between the +5V and GND test points (Figure 5-3).
5. Attach the digital multimeter (DMM) test leads to the resistor installed in

step 4 above.

6. Press POWER to ON, and adjust A13R6 (Figure 5-4) for approximately 5 volts.
7. Press POWER to OFF, and disconnect the resistor from P3.
8. Reconnect the PCBs and connectors disconnected in steps 2 and 3.

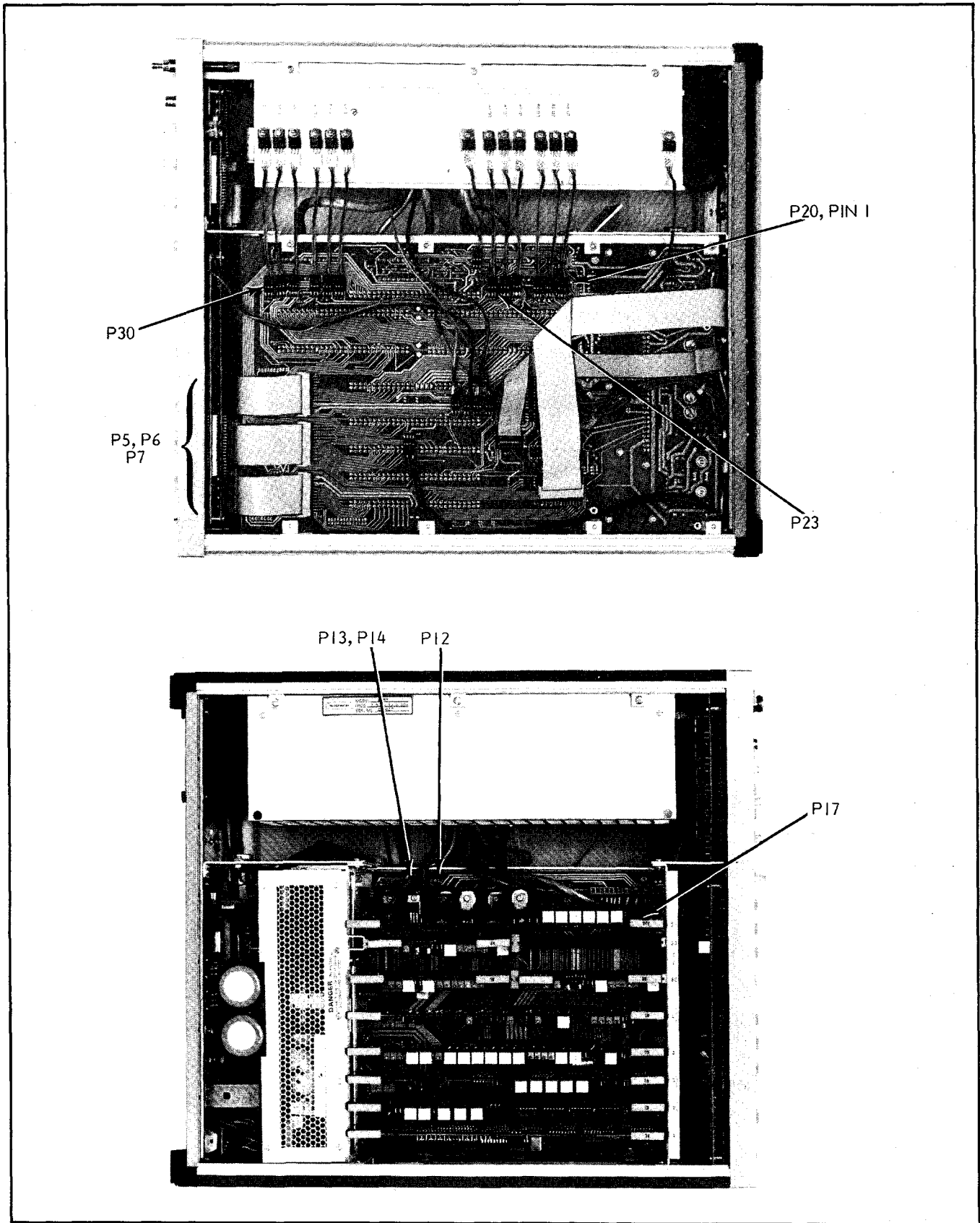

Figure 5-2. Connector Locations

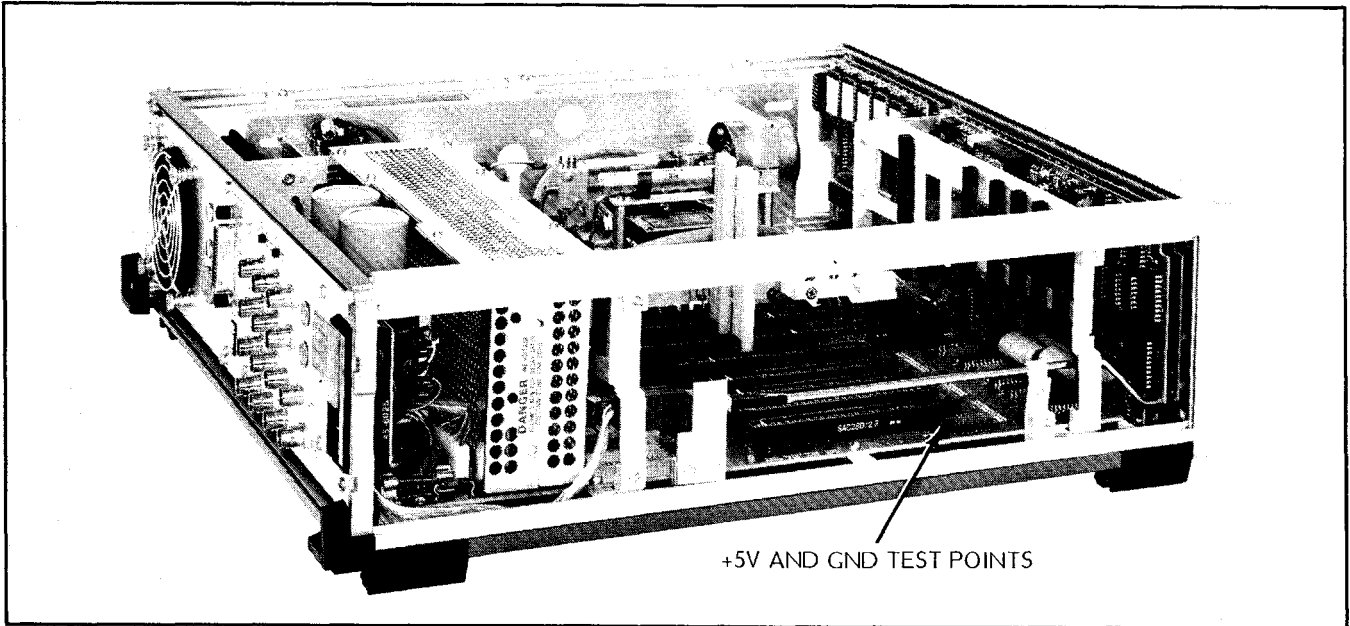

Figure 5-3. Connector P3, Pins 13 and 26

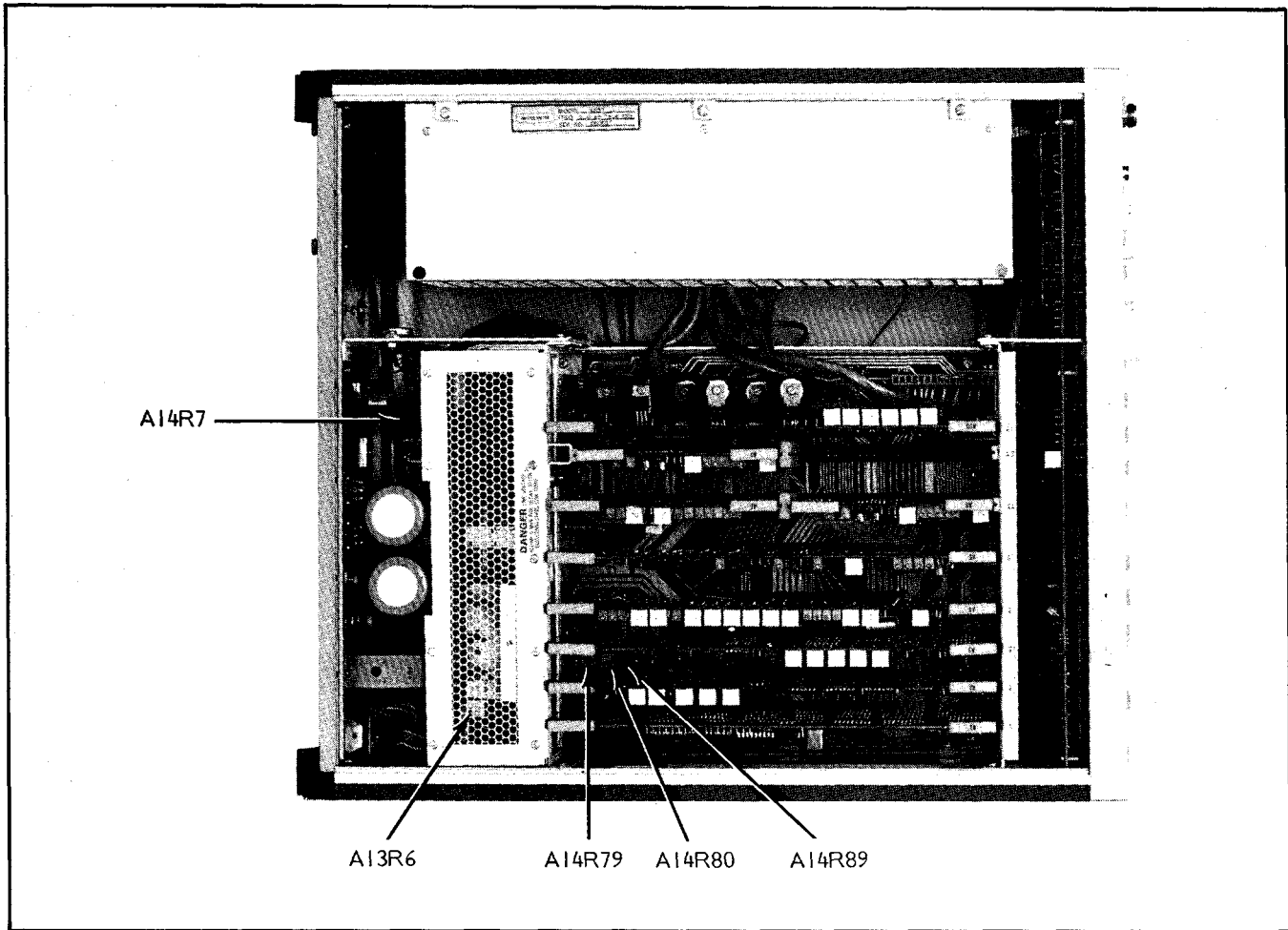

Figure 5-4. A13/A14 Power Supply Adjustments

9. Connect the DMM test leads between the +5V and GND test points.

10. Press POWER to ON and adjust A13R6 (Figure 5-4) for +5V \pm 1.0 mV.

b. -38 Volt Adjustment

1. Disconnect the DMM from P3 and connect it between A14P20, pin 1 (Figure 5-2), and chassis ground.

2. Adjust A14R7 (Figure 5-4) for -38V \pm 100 mV.

3. Remove the DMM from P20.

c. Out-of-Regulation Adjustment

1. Adjust A14R89 clockwise to its limit.

2. While observing the A14 OUT OF REG indicator, readjust A14R89 counterclockwise until the indicator goes out. Stop.

3. While counting the number of potentiometer turns, continue to adjust A14R89 counterclockwise until the indicator lights. Stop.

4. Readjust A14R89 clockwise halfway between the indicator's on and off states.

d. Low Line Voltage Adjustment

1. Press POWER to OFF.

2. Connect test equipment as shown in Figure 5-1.

3. Adjust the variac for 100 Vac (12% below the nominal line voltage), as observed on the line voltage monitor.

4. Press Power to ON.

5. Adjust A14R79 (LOW) to its clockwise limit; then readjust counterclockwise until the A14 LOW LINE indicator lights.

6. Readjust the variac for 115 Vac (nominal line voltage), and ensure the LOW LINE indicator is not lit.

e. High Line Voltage Adjustment

1. Adjust the variac for 130 Vac (12% above the nominal line voltage).

2. Adjust A14R80 (HIGH) to its clockwise limit; then readjust counterclockwise until the HIGH LINE indicator lights.

3. Readjust the variac for 115 Vac (nominal line voltage), and ensure the HIGH LINE indicator is not lit.

f. Voltage Regulation and Ripple Checks

The A13/A14 power supplies are well regulated and filtered. Also, the low- and high-line monitoring circuits are adjusted to flag their respective error codes well in advance of specified limits. Consequently, the power supply regulation and filtering (ripple) need not be checked on a periodic schedule. However, in the event that regulation or filtering problems are suspected, the specifications in Table 5-2 are provided.

5-5 A2 RAMP GENERATOR ADJUSTMENTS

This paragraph provides instructions for adjusting the voltage and time of the A2 sweep ramp. These adjustments should be checked and, if necessary, adjusted following maintenance on the A2 PCB, and when any of the frequency specifications are found to be out of tolerance.

a. Reference Supply Verification

1. Connect test equipment as shown in Figure 5-5, and turn the equipment on.

2. Remove the top cover from the sweep generator (sweeper). Refer to paragraph 7-3.1 for instructions, if necessary.

3. With the digital multimeter (DMM) referenced to A2TP5 (Figure 5-6), monitor A2U18

(a) pin 1 and verify the reference voltage is +12 \pm 1.0 volts;

Table 5-2. Power Supply Regulation and Ripple Specifications

VOLTAGE SUPPLY	MONITOR POINT	REF. POINT	REGULATION TOLERANCE	RIPPLE TOLERANCE (pk-pk)
+5V	A14TP3	A14TP4	± 3 mV	± 50 mV
+15V LC	XA6-8	Chassis	± 300 mV	± 10 mV
-15V LC	XA6-9	Chassis	± 300 mV	± 10 mV
+15V HC	XA10-24	Chassis	± 300 mV	± 10 mV
-15V HC	XA10-23	Chassis	± 300 mV	± 10 mV
+24V	A14P12-2	Chassis	± 300 mV	± 10 mV
-38V	A14P20-1	Chassis	± 300 mV	± 10 mV

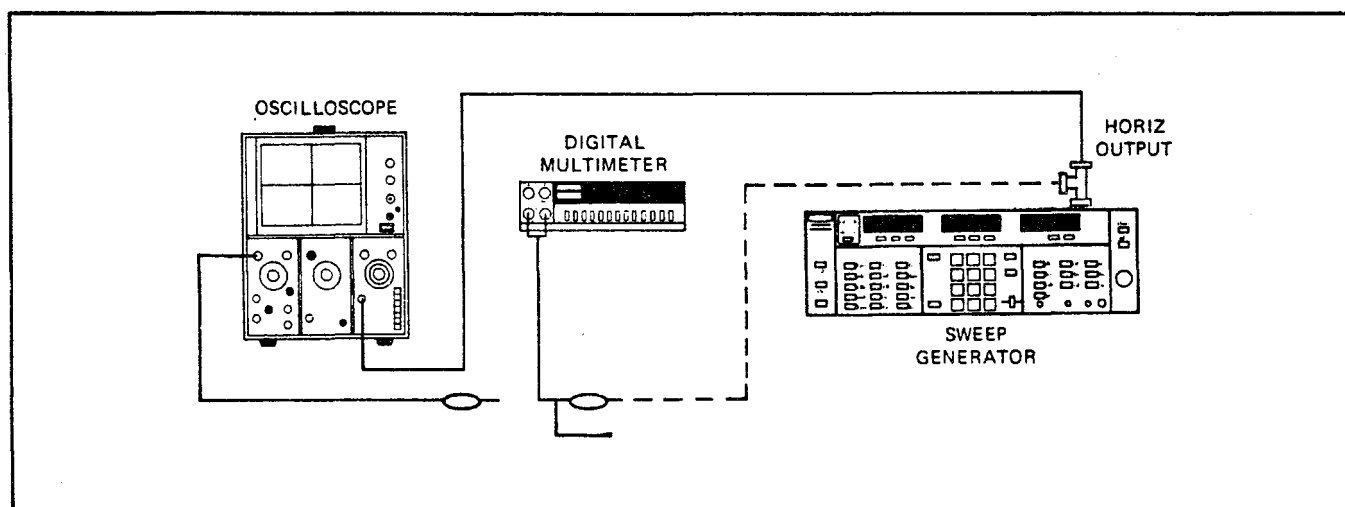

Figure 5-5. Test Equipment Setup for A2 Ramp Generator Adjustments

(b) pin 7 and verify the reference voltage is -12 ± 1.0 volts.

b. Ramp Voltage Adjustment

1. Press RESET on sweeper.
2. On the oscilloscope, set the horizontal time base for External, and adjust its Vernier control so that the trace extends the full width of the screen (10 divisions).
3. On the sweeper, press SWEEP TIME and set for 99 seconds.
4. Connect the DMM common lead to A2TP5; connect the "hot" lead to A2TP6.
5. While the ramp is sweeping in the forward direction, adjust A2R31 for $+10V \pm 1$ mV.
6. Move the DMM hot lead to A2TP7
7. After the ramp has swept thru its first 10 seconds (1 division), adjust A2R39 for $0V \pm 1$ mV.

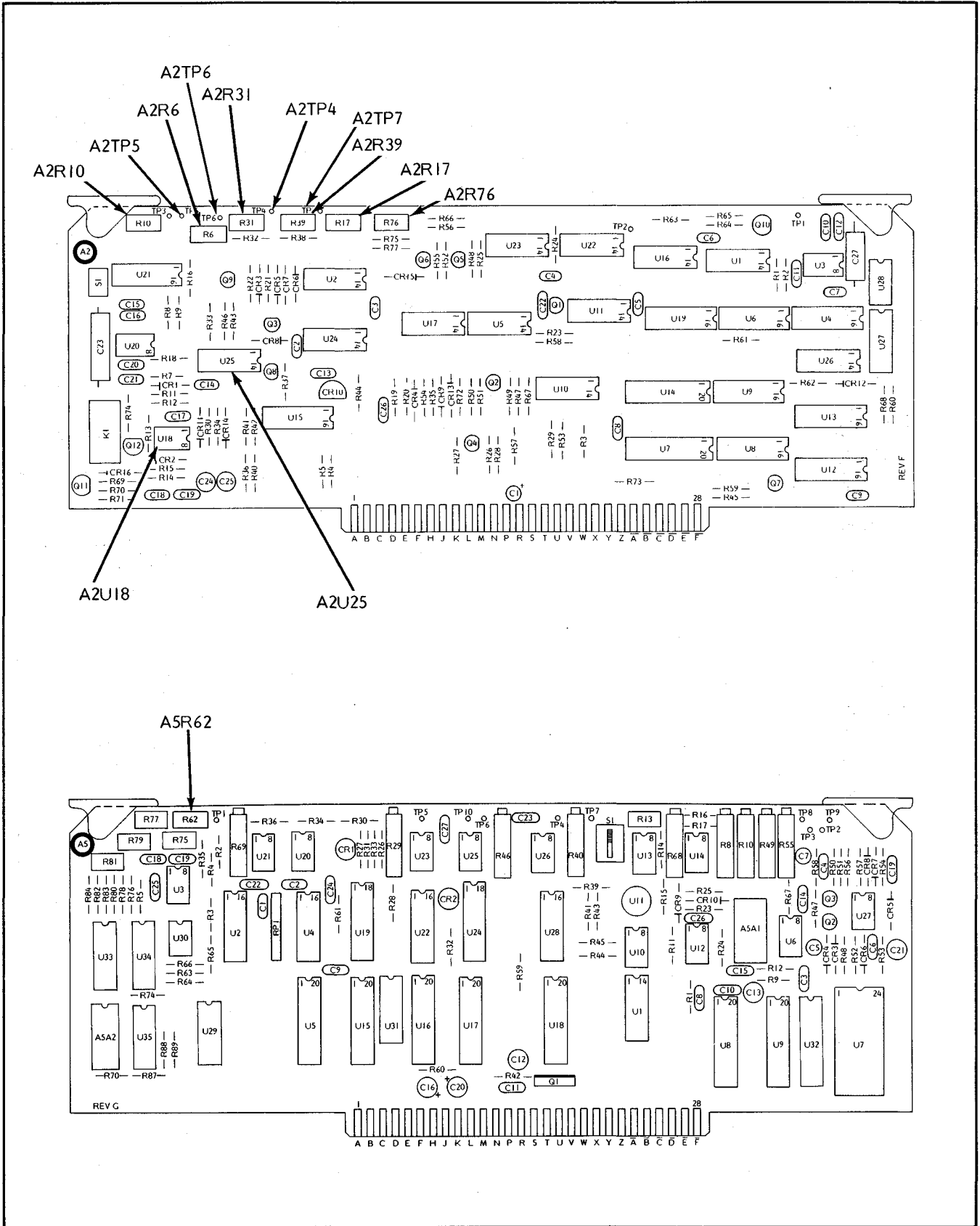

Figure 5-6. A2 Ramp Generator Adjustments

8. Disconnect the DMM leads from the A2 PCB, and move them to the rear panel HORIZ OUTPUT connector (hot lead to the center conductor, and common lead to the shield).
9. Ground the center conductor on the rear panel EXT SWEEP connector.
10. Press SHIFT and EXTERNAL SWEEP (place the A2 PCB INT-EXT switch in EXT, for sweepers without the SHIFT functions).
11. Adjust A5R62 (Figure 5-6) for $0V \pm 1$ mV.
12. Return the sweeper to AUTO sweep (INT-EXT switch back to INT) and remove the ground from the EXT SWEEP connector.

NOTE

The adjustment of A5R62 affects marker calibration. Check marker frequencies (paragraph 5-7) following the adjustment of A5R62.

c. Ramp-Voltage Clamping Adjustment

1. Disconnect the DMM leads from the HORIZ OUTPUT connector, and connect the test lead to A2TP4 and the common lead to A2TP5.
2. On the sweeper,
 - (a) press SWEEP TIME and set for 50 ms;
 - (b) press EXT OR SINGLE twice (trigger a single sweep);
 - (c) adjust A2R76 for $+10V \pm 1$ mV. (Allow 15-30 seconds for the voltage to settle, before taking a voltage reading.)
3. Disconnect the DMM leads from A2TP4 and A2TP5.

d. Sweep Time Adjustment

1. Connect the oscilloscope as follows:

- (a) probe to A2TP4,
- (b) ground to A2TP5.

2. Set the oscilloscope controls as follows:
 - (a) vertical to 2V per division,
 - (b) horizontal to 200 ms per division.
3. On the sweeper,
 - (a) press $\Delta F F0$;
 - (b) press SWEEP TIME and set for 0.999 seconds;
 - (c) adjust A2R10 for a forward sweep duration (Figure 5-7) of 1.0 ± 0.1 seconds.

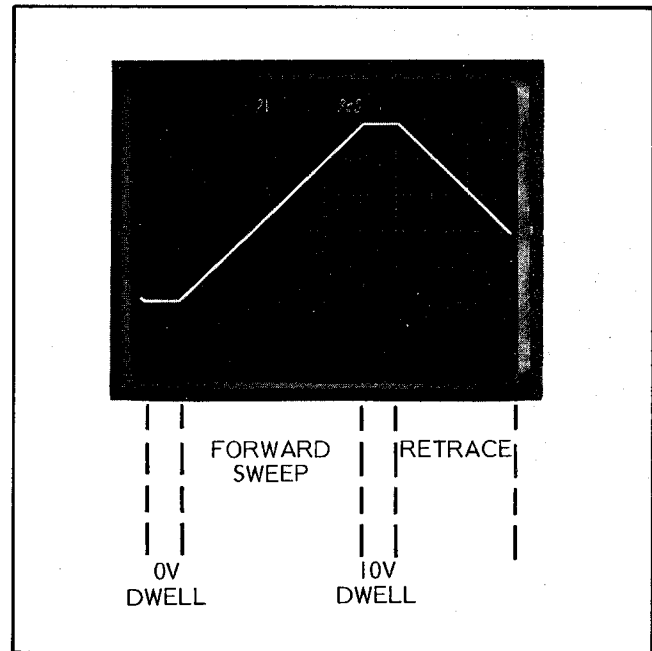

Figure 5-7. A2 Sweep Ramp

4. Set the oscilloscope horizontal for 2 ms per division.
5. On the sweeper,
 - (a) set SWEEP TIME for 10 ms;
 - (b) adjust A2R6 for a forward sweep duration of 10 ± 1 ms.
6. Set the oscilloscope horizontal control for 200 ms per division.

7. On the sweeper,
 - (a) set SWEEP TIME for 1 second;
 - (b) adjust A2R17 for a forward sweep duration of 1.0 ± 0.1 second.
8. With the oscilloscope, verify retrace and dwell times at 10 ms and 1 second. Retrace and dwell time specifications are shown in Table 5-3. If the retrace time is out of tolerance, check that +15V is present at A2R8 (Figure 7-33, Sheet 2). If +15V is present, troubleshoot A2U21D and associated resistors. If the dwell time is out of tolerance, troubleshoot the dwell timing circuit (paragraph 7-9.1b).

Table 5-3. Retrace and Dwell Time Specifications

SWEEP TIME	RETRACE TIME	DWELL TIME
10 ms to 0.999 s	10 ± 1 ms	5 ± 0.2 ms
1 s to 99 s	1 ± 0.1 s	5 ± 0.2 ms*

*At zero-volt dwell, dwell time is proportional to sweep time.

5-6 A5 FREQUENCY INSTRUCTION ADJUSTMENTS

This paragraph provides instructions for adjusting the A5 sweep width (ΔF) ramp, the A5 F Center DAC voltages, and the A6-A9 bandswitch reference voltages. These adjustments should be checked and, if necessary, adjusted following maintenance on any of the A5-A9 PCBs or when any of the frequency specifications are found to be out of tolerance.

a. Bandswitch Reference Voltage Adjustment

1. Set up the test equipment as shown in Figure 5-8 and turn the equipment on.
2. Remove the top cover from the sweep generator (sweeper). Refer to

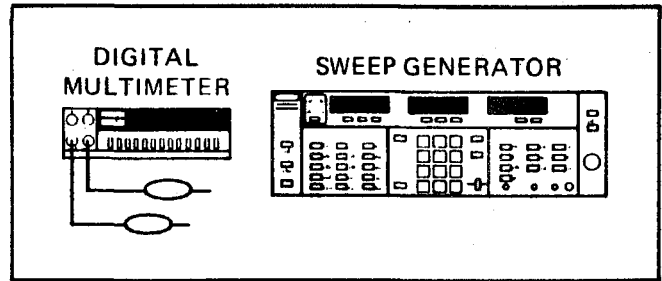

Figure 5-8. Setup for A5 Frequency Instruction Adjustments

paragraph 7-3.1 for instructions, if necessary.

3. Connect the common lead on the digital multimeter (DMM) to A5TP3 (Figure 5-9) and the test lead to A5TP9.
 4. Adjust A5R55 for $+10V \pm 1.0$ mV.
 5. Move the DMM test lead to A5TP8 and adjust A5R49 for -10 ± 1.0 mV.
- b. Sweep Width (ΔF) Signal Path Adjustments
1. Press RESET.
 2. Press SHIFT, then EXT SWEEP.
 3. Remove the DMM leads from A5TP8 and A5TP3. Connect a BNC-to-clip-lead jumper between the rear panel EXT SWEEP connector and A5TP9 and A5TP3 (center conductor to A5TP9).
 4. Connect the DMM test lead to A5TP5 and the common lead to A5TP10. Note the voltage level at A5TP5.
 5. Disconnect the BNC connector from EXT SWEEP; note the voltage value at A5TP5.
 6. Alternately connect and disconnect the BNC connector at the EXT SWEEP connector, and adjust A5R29 for equal TP5 voltages, ± 1.0 mV. Record this voltage value.

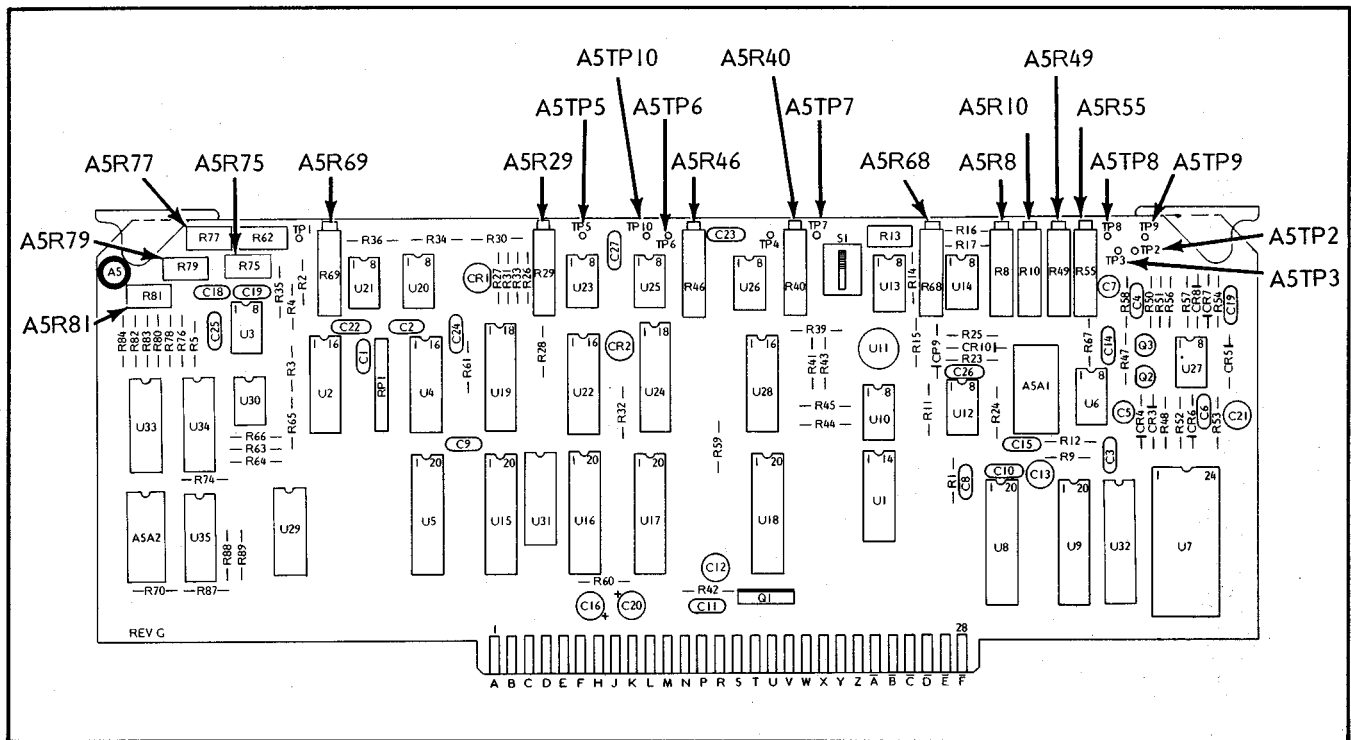

Figure 5-9. A5 Frequency Instruction Adjustments

7. Press MANUAL SWEEP, and rotate its associated control fully clockwise.
8. Adjust A5R69 for the voltage value recorded in step 6 above.
9. Rotate the MANUAL SWEEP control fully counterclockwise, and verify that the voltage at A5TP5 is the same as that recorded in step 10 above, ± 25.0 mV.
10. Rotate the MANUAL SWEEP control to midrange (0 volts at A5TP5).
11. Press ΔF F0.
12. Press ΔF and set for 0 MHz.
13. Move the DMM test lead to A5TP6.
14. Adjust A5R46 for $0V \pm 1.0$ mV.
15. Move the DMM test lead to A5TP7.
16. Adjust A5R40 for $0V \pm 1.0$ mV.

c. F Center Adjustments

1. Press TRIGGER AUTO.
2. Press CW F1 and verify it is set for the low-end frequency.
3. Move the DMM test lead to A5TP2 and the common lead to A5TP3.
4. Adjust A5R10 for the applicable voltage shown below, ± 1 mV:

Model	Voltage (mVdc)
6609A	50.0
6617A	12.5
6621A, 6621A-40	1,612.9
6629A, 6629A-40	4,301.0
6637A, 6637A-40	1,075.2
6638A	1,000.0
6642A	4,500.0
6647A	5.4
6648A	5.0
6653A	754.7
6659A	3.8

5. Press CW F2 and set for the high-end frequency.
6. Adjust A5R8 for $10V \pm 0.1$ mV.

7. Using CW F1 and CW F2, repeat (if necessary) the low- and high-end frequency adjustments until the voltages specified above are achieved.

d. Frequency-Band Overlap Adjustments
(Not for 6609A or 6642A)

1. Connect equipment as shown in Figure 5-10, and turn the equipment on.

2. Het Band Overlap Adjustment (Models 6617A, 6647A, 6648A, and 6659A)

(a) On the sweeper,

- (1) press RESET;
- (2) press ΔF F0;
- (3) press ΔF and set for 250 MHz;
- (4) press F0 and set for 2 GHz;
- (5) press SWEEP TIME and set for 20 seconds.

(b) On the spectrum analyzer,

- (1) press FREQUENCY RANGE GHz as appropriate to display the F0 frequency;
- (2) adjust TUNING for the frequency that was set in step

2 (a)(4) above;

- (3) position INPUT ATTEN so that the top of the swept-frequency display is visible (Figure 5-11);

- (4) adjust INTENSITY and PERSIST so that the overlap width shows up as an intensification of the swept display (Figure 5-11).

- (c) On the sweeper, adjust A5R81 for a frequency overlap of 5 MHz.

3. Osc 1 Overlap Adjustment (Models 6621A, 6621A-40, 6637A, 6637A-40, 6638A, 6647A, 6648A, 6653A, and 6659A)

- (a) For 6647A, 6648A, and 6659A: press F0 and set for 8 GHz.

- (b) For all other models: perform step 2(a), (1) thru (4), but set F0 for 8 GHz.

- (c) Perform step 2(b), (1) thru (4).

- (d) On sweeper, adjust A5R79 for a frequency overlap of 5 MHz.

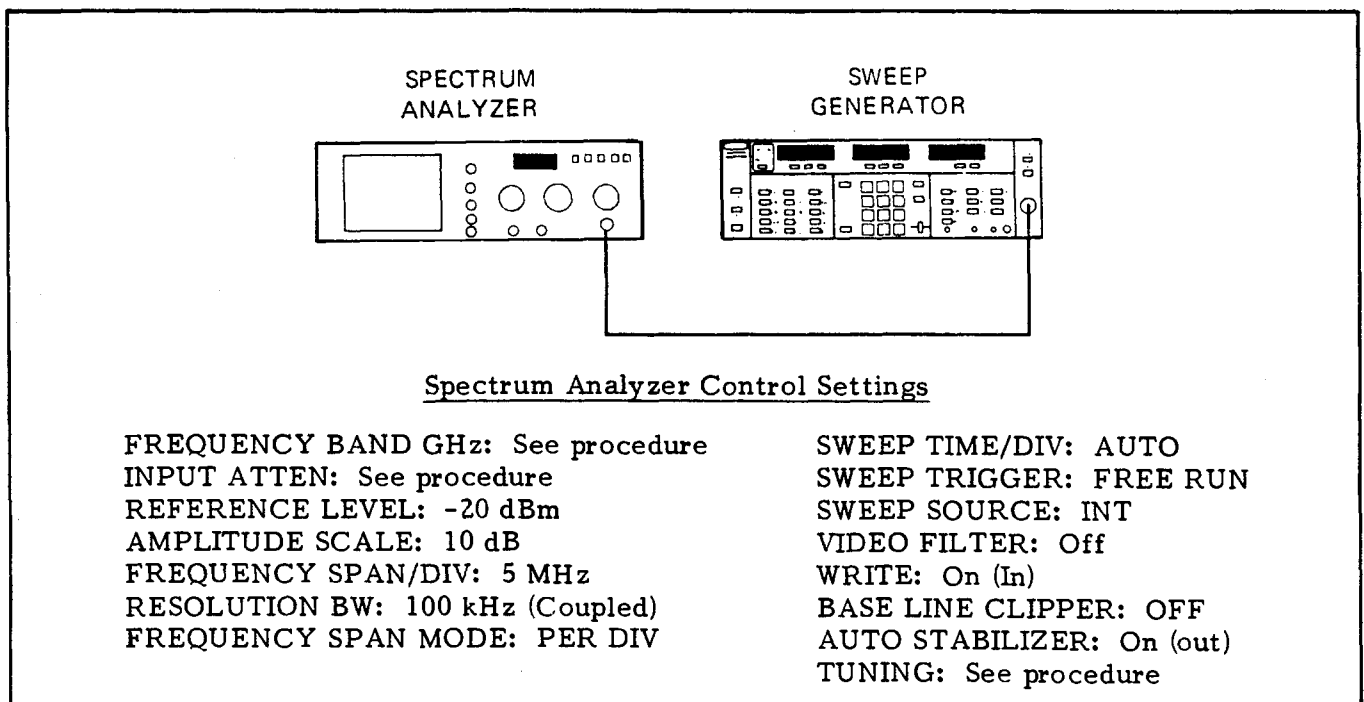

Figure 5-10. Test Equipment Setup For Frequency-Band Overlap Test

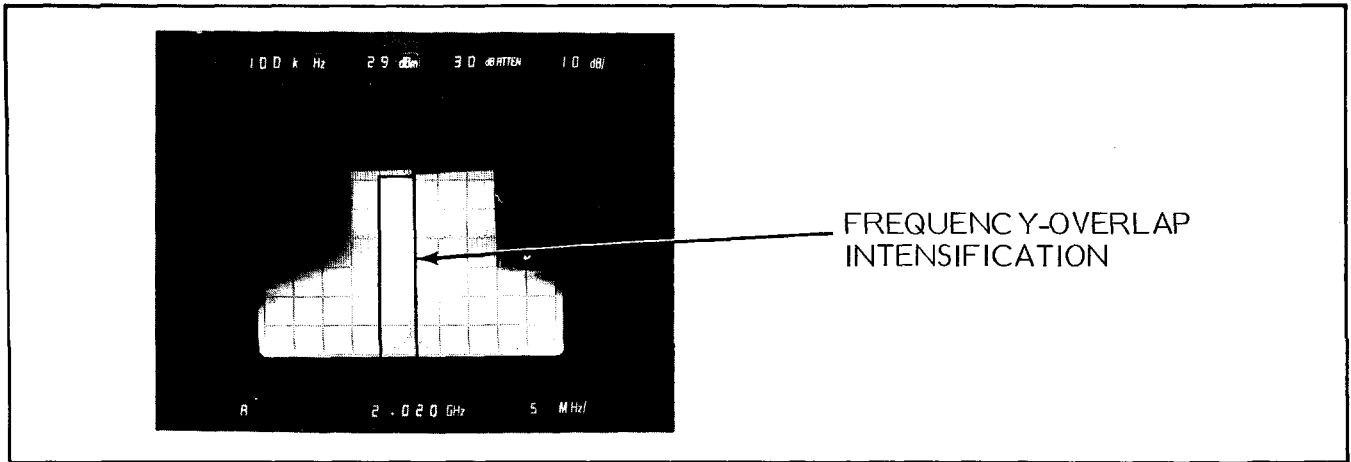

Figure 5-11. Swept-Frequency Display, Showing Frequency Overlap

4. Osc 2 Overlap Adjustment (Models 6629A, 6629A-40, 6637A, 6637A-40, 6638A, 6647A, 6648A, 6653A, and 6659A)

- (a) For 6629A and 6629A-40: perform steps 2(a), (1) thru (4), but set F0 for 12.4 GHz.
- (b) For all other models: press F0 and set for 12.4 GHz.
- (c) Perform steps 2(b), (1) thru (4).
- (d) On the sweeper, adjust A5R77 for a frequency overlap of 5 MHz.

5. Osc 3 Overlap Adjustment (Models 6653A and 6659A)

- (a) Press F0 and set for 18 GHz.
- (b) Perform steps 2(b), (1) thru (4).
- (c) On the sweeper, adjust A5R75 for a frequency overlap of 5 MHz.

e. V/GHz Adjustment

1. Press F1 and set for the high-end frequency.
2. Connect the DMM leads to the rear panel 1V/GHz connector.
3. Adjust A5R68 for a voltage value equal to 1V per GHz, ± 2.0 mV, of F1 frequency (0.5V/GHz for the 6642A, 6653A, and 6659A). Example: If the

high-end frequency is 2 GHz (6609A), adjust A5R68 for 2.0 volts, ± 2.0 mV. If the high-end voltage is 18.6 GHz (6647A), adjust A5R68 for 18.6 volts, ± 2.0 mV. And if the high-end frequency is 26.5 GHz (6653A), adjust A5R68 for 13.25 volts, ± 2.0 mV.

4. Press F1 and set for the low-end frequency.
5. Verify that the DMM reads a voltage value equal to 1V/GHz, ± 25.0 mV, of F1 frequency.

5-7 **A3 MARKER GENERATOR ADJUSTMENTS**

This paragraph provides instructions for adjusting both the F0, M1, and M2 marker frequencies and the MODIFY SIGNAL output voltage from the front panel INCREASE/DECREASE lever. These adjustments should be checked and, if necessary, adjusted following maintenance on the A3 PCB.

Two methods for adjusting the marker frequencies are provided: (1) using the Model 560 or 560A Scalar Network Analyzer and (2) using an oscilloscope. The method using the 560 or 560A (subparagraph c) is preferred. If a 560 or 560A is not available, an alternate procedure using an oscilloscope is described in subparagraph b.

The reference voltage check in subparagraph a. below should be performed before adjusting the marker frequencies.

a. A3 Reference Voltage Check

1. Remove the top cover from the sweep generator (sweeper). Refer to paragraph 7-3.1 for instructions.
2. Press POWER to ON.
3. Press RESET.
4. With a digital multimeter (DMM) referenced to A3TP1 (Figure 5-13),
 - (a) monitor A3U3 pin 1 (R33 lead nearest top edge of PCB); verify voltage is $-10 \pm 0.25V$.
 - (b) monitor A3U3 pin 7 (middle terminal on R13); verify the voltage is $-10 \pm 0.25V$.
5. If either voltage is out of tolerance, troubleshoot A3U3 and its associated components before continuing with this procedure.

b. Marker Frequency Calibration Using an Oscilloscope

1. Set up the test equipment as shown in Figure 5-12, and turn the equipment on.

2. Connect the DMM "hot" lead to the center conductor of the rear panel HORIZ OUTPUT connector; connect the common lead to the shield.
3. Ground the center conductor on the rear panel EXT SWEEP connector.
4. Press SHIFT and EXT SWEEP (place the A2 PCB INT/EXT switch in EXT, for sweepers without the SHIFT functions).
5. Adjust A5R62 (Figure 5-12) for $0V \pm 1$ mV.
6. Return the sweeper to AUTO sweep (INT/EXT switch back to INT) and remove the ground from the EXT SWEEP connector.
7. Disconnect the DMM from the HORIZ OUTPUT connector.
8. On the sweeper,
 - (a) press MARKERS VIDEO;
 - (b) rotate MARKER AMPLITUDE fully clockwise;
 - (c) press F0 and set for the high-end frequency;

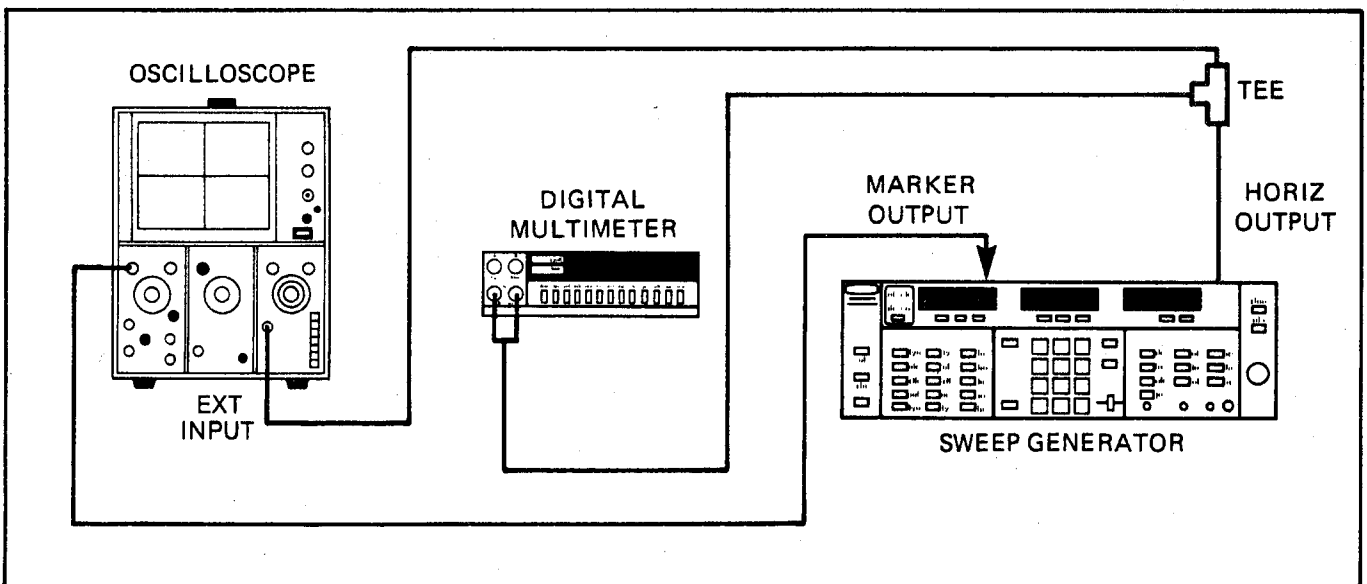

Figure 5-12. Test Equipment Setup for A3 Marker Generator Adjustments

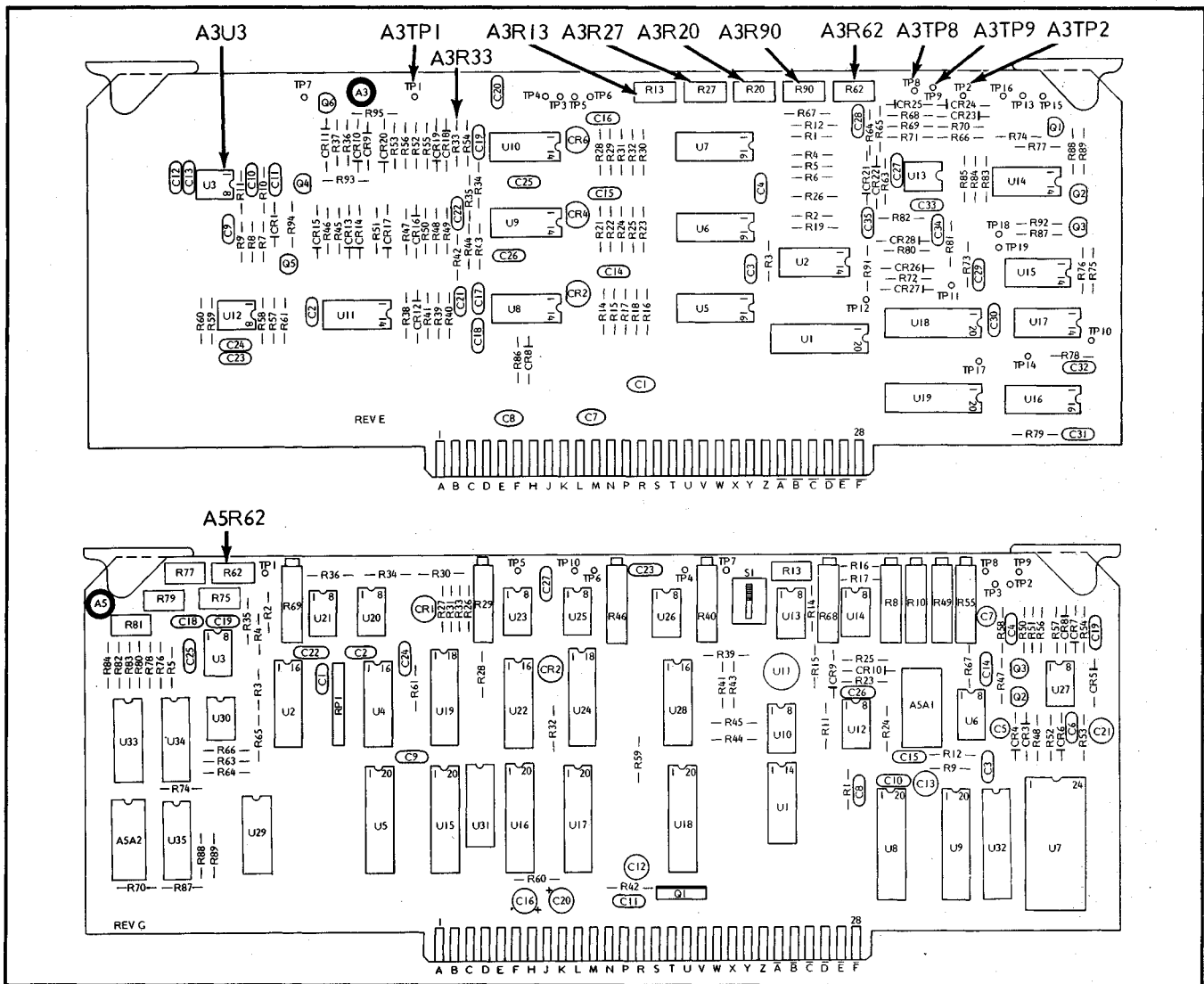

Figure 5-13. A3 Marker Generator Adjustments

- (d) adjust A3R13 (Figure 5-13) until the F0 marker is just visible on the right edge of the oscilloscope display, as shown in Figure 5-14;
- (e) set F0 for 10 GHz;
- (f) press M1 and set for the high-end frequency;
- (g) using A3R20, repeat step (d) above for the M1 marker;
- (h) set M1 for 12 GHz;
- (i) press M2 and set for high-end frequency;
- (j) using A3R27, repeat step (d) above for the M2 marker.

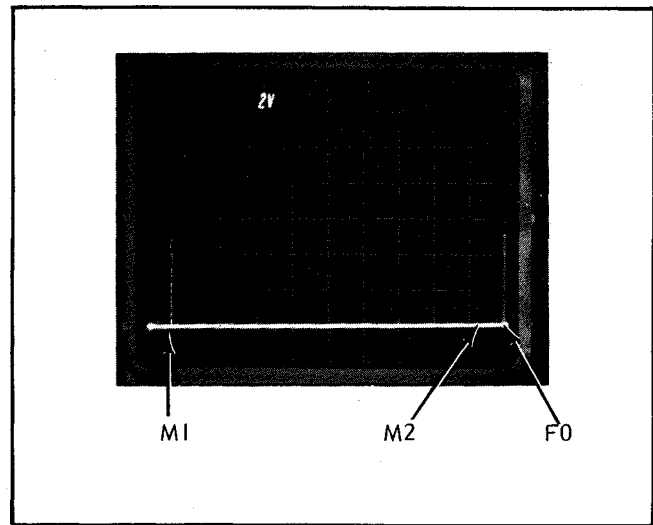
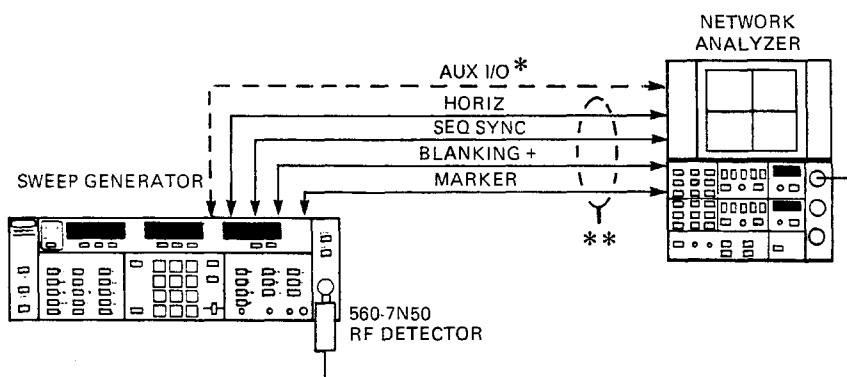

Figure 5-14. F0, M1, and M2 Markers

c. Marker Frequency Calibration Using the Model 560 or 560A Scalar Network Analyzer

1. Set up the test equipment as shown in Figure 5-15, and turn the equipment on.
2. On the sweeper,
 - (a) press RESET;
 - (b) press SHIFT, then CW RAMP;
 - (c) press MARKERS VIDEO;
 - (d) rotate MARKERS AMPLITUDE fully clockwise.
3. On the network analyzer,
 - (a) adjust Channel A OFFSET to position the trace in the center of the display;
4. On the sweeper,
 - (a) press F0 and set for high-end frequency;
 - (b) adjust A3R13 (Figure 5-13) until the F0 marker is just visible on the right edge of the 560 display, as shown in Figure 5-16.
 - (c) set F0 for 10 GHz;
 - (d) press M1 and set for high-end frequency;
 - (e) using A3R20, repeat step (b) above for the M1 marker;



Initial Control Settings

Sweep Generator

MARKER AMPLITUDE: Fully CW
 HORIZ OUTPUT DURING CW
 (rear panel): ON
 SLOPE: OFF

*Used with 560A. Also set:
 HORIZONTAL SELECT: 10V
 Z-AXIS SEL: EXT

**560 only.

Scalar Network Analyzer

CHANNEL A ON: On
 INPUT: A
 MEMORY: Off
 dB PER DIVISION: 5
 REFERENCE dB/dBm: dBm
 SET (screwdriver pot): Midrange
 OFFSET: +10
 CHANNEL B: Not used
 MARKER THRESHOLD: Midrange
 REAL TIME: On
 SMOOTHING: Off
 POWER: On

Figure 5-15. Test Setup for Marker Frequency Adjustment, Using the Model 560 or 560A Scalar Network Analyzer

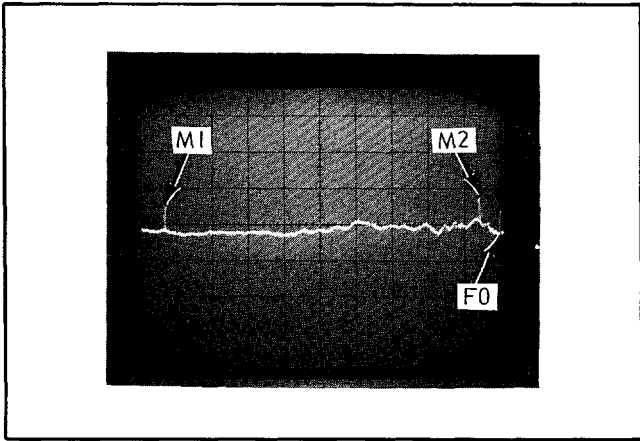

Figure 5-16. Model 6637A Markers, as shown on 560 Display

- (f) set M1 for 12 GHz;
- (g) press M2 and set for high-end frequency;

(h) using A3R27, repeat step (b) above for the M2 marker.

d. INCREASE/DECREASE Lever Voltage Adjustment

1. Connect the common lead on the DMM to A3TP2, and the test lead to A3TP8.
2. Move the INCREASE/DECREASE lever to full INCREASE; release the lever and allow it to spring back to the center. Note the voltage value.
3. Move the INCREASE/DECREASE lever to full DECREASE; release the lever and allow it to spring back to the center. Note the voltage value.
4. Repeat steps 2 and 3, and adjust A12R46 (Figure 5-17) until the noted

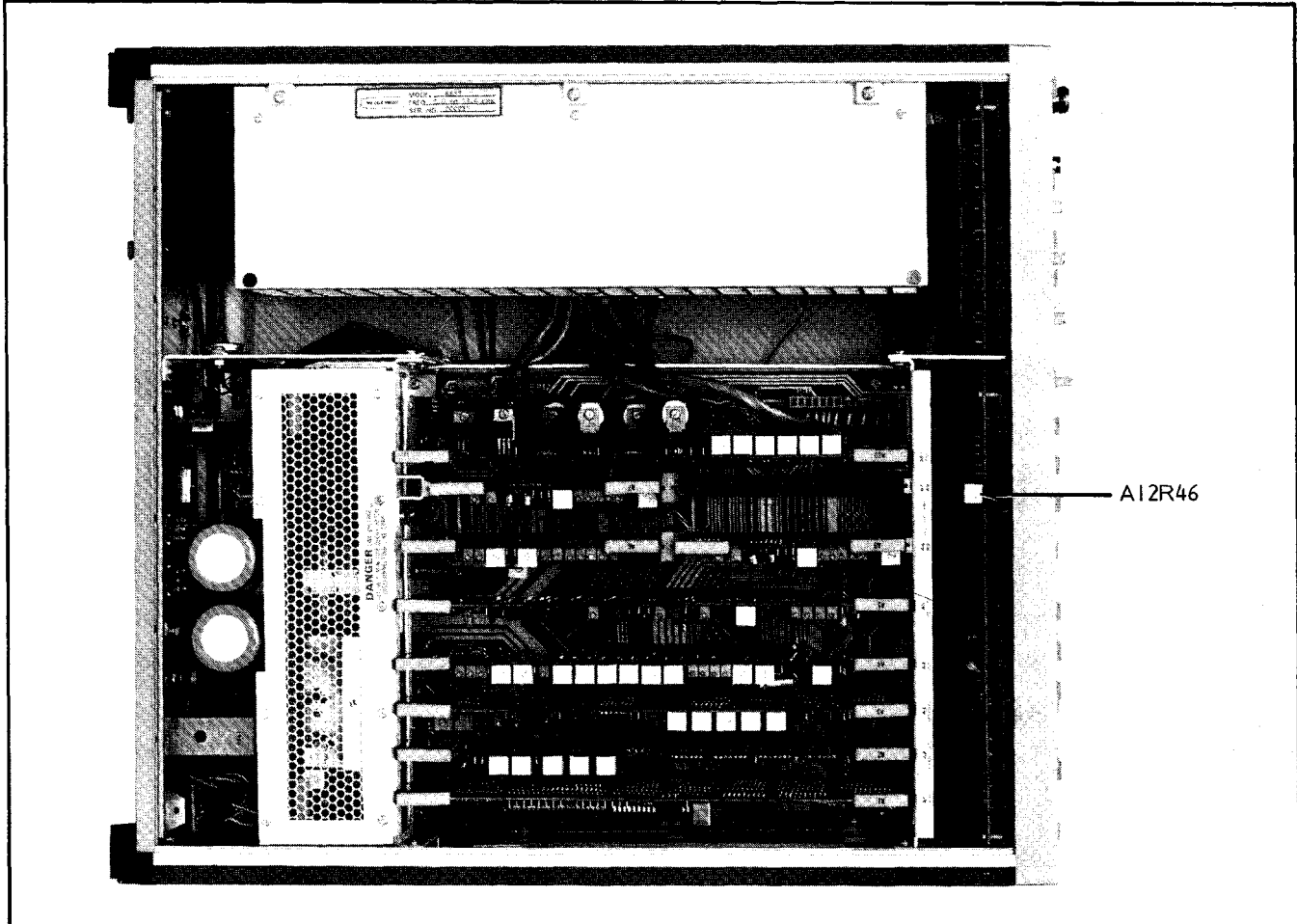

Figure 5-17. A12R46 Adjustment Location

voltages are equal, ± 200 mV. Voltage value should be between 0 and ± 0.5 V.

5. Transfer the DMM test lead to A3TP9.
6. Move the INCREASE/DECREASE lever to its full INCREASE position, and adjust A3R62 (Figure 5-13) for $+4.8\text{V} \pm 20$ mV.
7. Move the INCREASE/DECREASE lever to its full DECREASE position, and adjust A3R90 for $+4.8\text{V} \pm 20$ mV.

5-8 A6-A9 YIG (HET/YIG) DRIVER PCB ADJUSTMENTS

Procedures for adjusting the A6-A9 YIG (Het/YIG) Driver PCBs are provided in paragraphs 5-8.1 and 5-8.2. Depending upon model, the 6600A Series sweep generators have from 1 to 4 YIG Driver PCBs installed. There are two field-level adjustments on each YIG Driver PCB: YIG bias and oscillator-bandswitching voltage. The bandswitching-voltage adjustments, plus an adjustment on the A5 PCB that must be performed at the highest bandswitch point for each model, are described in paragraph 5-8.1. The YIG bias adjustments are described in paragraph 5-8.2.

5-8.1 A6-A9 Oscillator-Bandswitching Voltage Adjustments

This paragraph provides instructions for ad-

justing the A6-A9 PCB oscillator-bandswitching voltages. These adjustments should be performed following maintenance on the A6-A9 PCBs. A guide directing which steps need to be performed for which model numbers is provided in Table 5-4.

Table 5-4. Model Number Guide to A6-A9 PCB Bandswitching-Voltage Adjustments in Paragraph 5-8.1

MODEL	PERFORM SUBPARAGRAPH(S)
6609A	-----
6617A	a., b., c., g.
6621A & 6621A-40	a., b., d., g.
6629A & 6629A-40	a., b., e., g.
6637A & 6637A-40	a., b., d., e., g.
6638A	a., b., d., e., g.
6642A	a., b., d., g.
6647A	a., b., c., d., e., g.
6648A	a., b., c., d., e., g.
6653A	a., b., d., e., f., g.
6659A	a., b., c., d., e., f., g.

- a. Set up the test equipment as shown in Figure 5-18, and turn the equipment on.

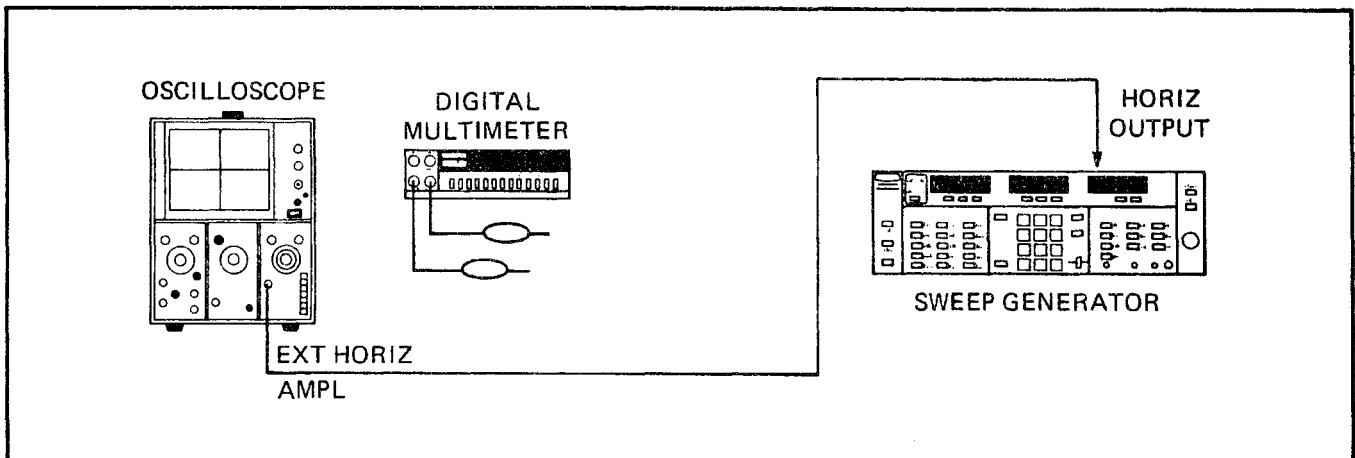

Figure 5-18. Test Equipment Setup for the A6-A9 YIG Driver Adjustments

b. Remove the top cover from the sweep generator (sweeper). Refer to paragraph 7-3.1 for instructions, if necessary.

c. A6 PCB, 2 GHz Bandswitching-Voltage Adjustment.

1. Press RESET on sweeper.
2. Press CW F1 and set for 2 GHz.
3. Connect the DMM test lead to A6TP5; connect the common lead to A6TP1 (Figure 5-19).
4. Adjust A6R65 clockwise until the DMM reads $\approx 0V$ (TTL low).
5. Readjust A6R65 counterclockwise until the DMM reads $\approx +5V$ (TTL high).
6. For the 6617A, rotate the 8 GHz bandswitching adjustment (R58) fully clockwise.

d. A6 PCB 8 GHz (or 26.5 GHz for Model 6642A) Bandswitching-Voltage Adjustment

1. Press CW F1 and set for 8 (or 26.5) GHz.
2. Move the DMM test lead to A6TP4.
3. Adjust A6R58 clockwise until the DMM reads $\approx 0V$ (TTL low).
4. Readjust A6R58 counterclockwise until the DMM reads $\approx +5V$ (TTL high).
5. For the 6621A, 6621A-40, and 6642A, rotate the A7 PCB bandswitching adjustment (A7R68) fully clockwise.

e. A7 PCB Bandswitching-Voltage Adjustment

1. Press CW F1 and set for 12.4 GHz.
2. Connect the DMM test lead to A7TP4

(Figure 5-20); connect the common lead to A7TP1.

3. Adjust A7R68 counterclockwise until the DMM reads $\approx 0V$ (TTL low).
4. Readjust A6R58 counterclockwise until the DMM reads $\approx +5V$ (TTL high).
5. For the 6629A, 6629A-40, 6637A, 6637A-40, 6638A, 6647A, and 6648A, rotate the A8 PCB bandswitching adjustment (A8R68) fully clockwise.

f. A8 PCB Bandswitching-Voltage Adjustment (6653A/6659A)

1. Press CW F1 and set for 18 GHz.
2. Connect the DMM test lead to A8TP4 (Figure 5-20); connect the common lead to A8TP1.
3. Adjust A8R68 counterclockwise until the DMM reads $\approx 0V$ (TTL low).
4. Readjust A8R68 clockwise until the DMM reads $\approx +5V$ (TTL high).

g. A5 Volts-Per-Frequency Adjustment

1. Press FREQUENCY RANGE ΔF F0.
2. Press F0 and set for the frequency shown below:

<u>Model</u>	<u>Frequency (GHz)</u>
6617A	2.000
6621A & 6621A-40	8.000
6642A	26.500
6653A & 6659A	18.000
All Others	12.400

3. Adjust the oscilloscope vertical controls to obtain a horizontal trace, as shown in Figure 5-21.
4. Adjust A5R13 on the Frequency Instruction PCB to center the band-switch intensity-dot on the oscilloscope display (Figure 5-21).

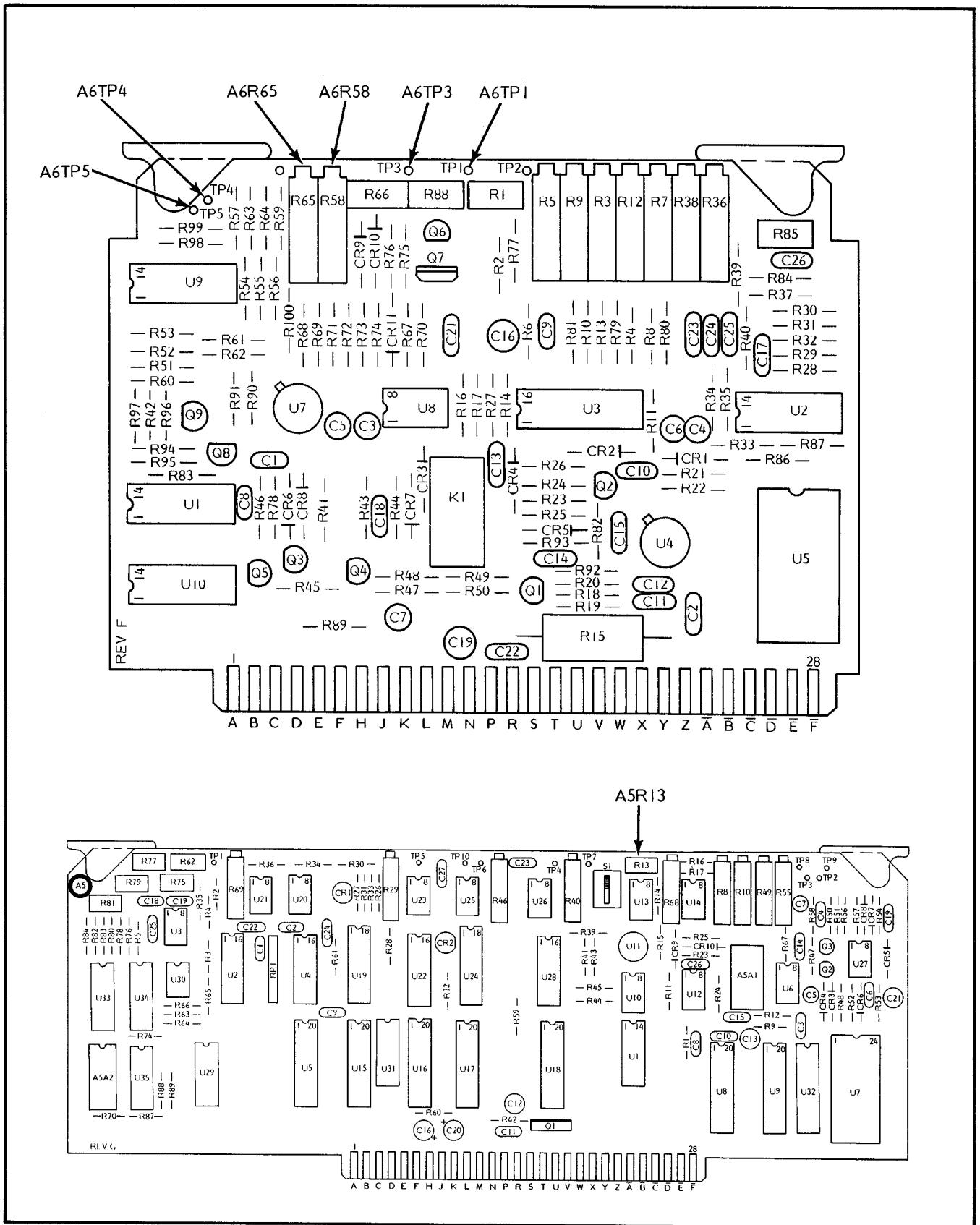

Figure 5-19. A6 YIG Driver Adjustments

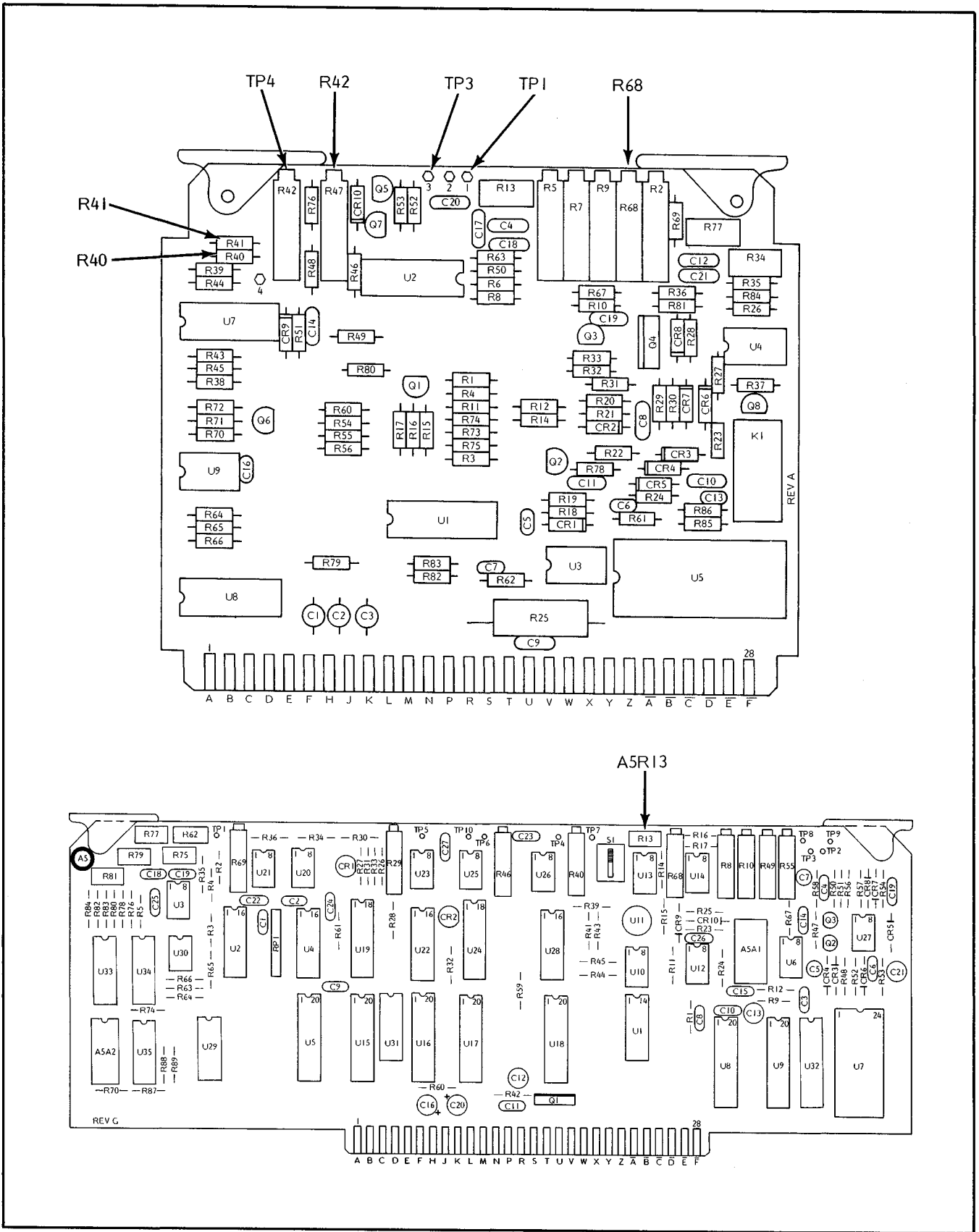

Figure 5-20. A7-A9 YIG Driver Adjustments

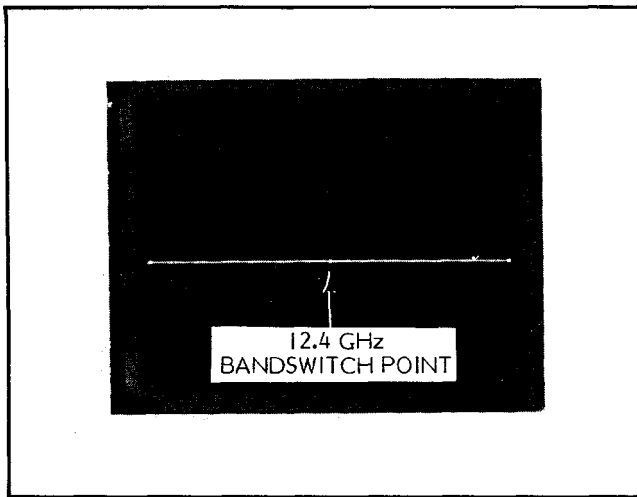

Figure 5-21. Bandswitch Dwell Signal

5-8.2 YIG Bias Check

This paragraph provides instructions for checking YIG oscillator bias voltage(s). YIG-oscillator bias is a factory adjustment that is not normally required except when a YIG oscillator has been replaced or maintenance has been performed in the A6-A9 PCB bias circuit. When a YIG oscillator is replaced, however, no bias adjustment is required by the user because WILTRON supplies a fully calibrated replacement YIG and YIG driver PCB. (The YIG driver PCB must be replaced with the YIG oscillator, because of the uniquely programmed linearizer ROM.) After maintenance in the bias circuit or during troubleshooting, check and adjust YIG bias as follows:

CAUTION

When a replacement YIG has been installed or maintenance has been performed in the A6-A9 PCB YIG bias circuitry, check that the RF Deck-mounted bias-output transistor Q3 is not short-circuited BEFORE APPLYING POWER TO THE YIG.

- a. Set up the equipment as shown in Figure 5-22, and turn the equipment on.
- b. Remove the top cover from the sweep

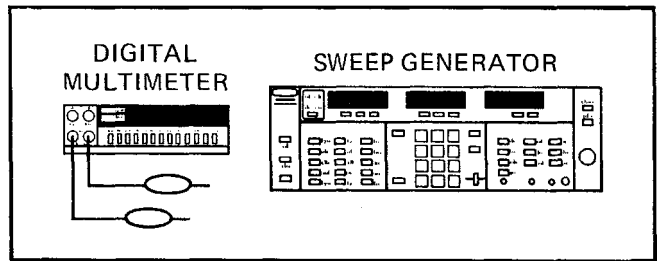

Figure 5-22. Test Equipment Setup for A8 YIG Driver Bias Adjustments

generator; refer to paragraph 7-3.1, if necessary.

c. A6 PCB YIG Bias Check

1. For all models except 6629A, 6629A-40 and 6642A:
 - (a) Connect the digital multimeter (DMM) test lead to A6TP3 (Figure 5-19); connect the common lead to A6TP1.
 - (b) Verify that the DMM reads -5 ± 0.2 Vdc.
2. For the 6629A, 6629A-40, and 6642A: Perform the steps in subparagraph d. below.

d. A7-A9 PCB YIG Bias Check and Adjustment

1. Look in the upper-left quadrant of the applicable A7-A9 PCB and determine whether resistors R40 and R41 are installed (Figure 5-20).
 - (a) If the resistors are installed, the YIG uses a sweeping-bias voltage. Proceed to step 2.
 - (b) If the resistors are not installed, the YIG uses a fixed-bias voltage. Proceed to step 3.
2. Sweeping-Bias Voltage Check and Adjustment Procedure
 - (a) Remove the cover from the RF Deck Assembly, and read the bias voltage stamped on the applicable YIG oscillator. Typically, the bias-voltage annotation

will read as follows: "BIAS -12.0V -9.0V." The first value is the low-end voltage; the second value is the high-end voltage. These are nominal voltage values.

- (b) Connect the digital multimeter (DMM) test lead to TP3 (Figure 5-20); connect the common lead to TP1.
- (c) Press RESET.
- (d) Press FREQUENCY RANGE F1-F2.
- (e) Press F1 and set for the applicable YIG's low-end voltage (Table 5-5).
- (f) Press F2 and set for the applicable YIG's high-end voltage.
- (g) Press MANUAL SWEEP and rotate its associated control fully counterclockwise.
- (h) If maintenance has been per-

formed on the bias circuit and the voltage is being adjusted, refer to step (1); otherwise, refer to step (2).

- (1) Adjust R47 for the low-end bias voltage stamped on the YIG.
- (2) Check that the bias voltage is approximately equal to the bias voltage value stamped on the YIG.
- (i) Rotate the MANUAL SWEEP control fully clockwise.
- (j) If maintenance has been performed on the bias circuit and the voltage is being adjusted, refer to step (1); otherwise, refer to step (2).
 - (1) Adjust R42 for the high-end bias voltage stamped on the YIG.
 - (2) Check that the bias voltage is approximately equal to the bias-voltage value stamped on the YIG.

Table 5-5. Oscillator Frequencies

OSCILLATOR BAND	MODEL(S)	FREQUENCY (GHz)	
		LOW END	HIGH END
1	6617A, 6621A, 6621A-40, 6637A, 6637A-40, 6638A, 6647A, 6653A, 6659A	2.000	8.000
1	6642A	18.000	26.500
2	6621A, 6621A-40, 6629A, 6629A-40, 6637A, 6637A-40, 6638A, 6647A, 6648A, 6653A, 6659A	8.000	12.400
2	6642A	26.500	40.000
3	6629A, 6629A-40, 6637A, 6637A-40, 6638A, 6647A, 6648A	12.400	18.600
3	6653A, 6659A	12.400	18.000
4	6653A, 6659A	18.000	26.500

age is approximately equal to the bias-voltage value stamped on the YIG.

3. Fixed-Bias Voltage Check and Adjustment Procedure

- (a) Press POWER to OFF.
- (b) Remove the A7 PCB and note whether its assembly number is 660-D-8008 or -8009 (-8190 or -8191 respectively for the 6642A). This information will be used in steps (f) and (g).
- (c) Reinstall the PCB, and press POWER to ON.
- (d) Connect the test lead of the digital multimeter (DMM) to TP3; connect the common lead to TP1.
- (e) Press RESET.
- (f) PCB assembly 660-D-8008 (8190): If maintenance has been performed in the bias circuit and the voltage is being adjusted, refer to step (1); otherwise, refer to step (2).
 - (1) Adjust R47 for -5 Vdc.
 - (2) Check that the bias voltage is approximately -5 Vdc.
- (g) PCB Assembly 660-D-8009 (-8191): If maintenance has been performed in the bias circuit and the voltage is being adjusted, refer to step (1); otherwise, refer to step (2).
 - (1) Adjust R47 for +15 Vdc.
 - (2) Check that the bias voltage is approximately +15 Vdc.

5-9 FREQUENCY CALIBRATION

This paragraph provides instructions for calibrating the sweep generator's frequency. Frequency calibration procedures are provided for each Osc 1 thru Osc 4 YIG-tuned oscillator, and for the Het Band for Models 6617A, 6647A, 6648A, and 6659A. For the

6609A, the Osc 1 procedure provides calibration instructions for its Het Band. A guide directing which procedures apply to which models is provided in Table 5-6. The sweep generator output frequency should be calibrated following maintenance on the A2, A5, and A6-A9 PCBs, and when any of the YIG oscillators are replaced.

Table 5-6. Model Number Guide to Frequency Calibration Adjustments in Paragraph 5-9

MODEL	PERFORM SUBPARAGRAPH(S)
6609A	a. thru d.
6617A	a. thru e.
6621A & 6621A-40	a. thru d., f.
6629A & 6629A-40	a. thru c., f., g.
6637A & 6637A-40	a. thru d., f., g.
6638A	a. thru d., f., g.
6642A	a. thru d., f.
6647A	a. thru g.
6648A	a. thru g.
6653A	a. thru d., f. thru h.
6659A	a. thru h.

- a. Set up test equipment as shown in Figure 5-23, and turn the equipment on.
- b. Remove the top cover from the sweep generator (sweeper). Refer to paragraph 7-3.1 for instructions, if necessary.
- c. Press RESET on sweeper.
- d. Osc 1 Frequency Calibration

CAUTION

To prevent misalignment due to being on the wrong side of the YIG oscillator's hysteresis curve, steps 1 thru 7 should be followed exactly as written.

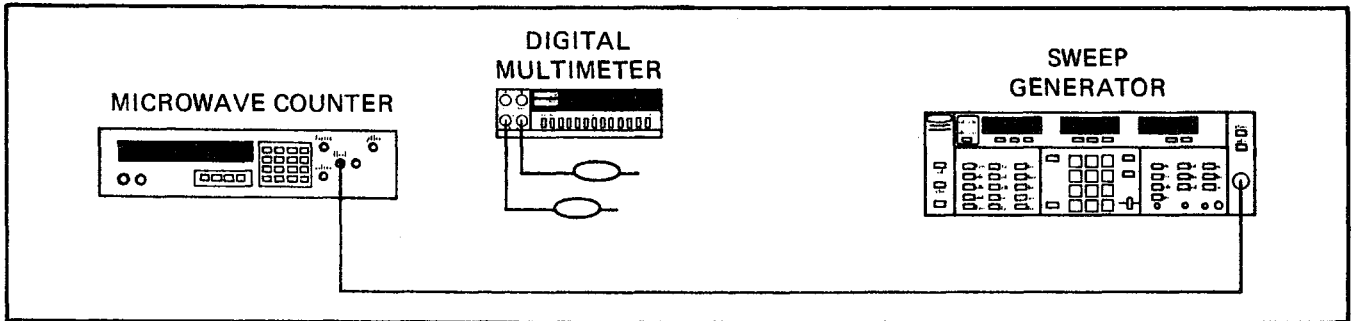

Figure 5-23. Test Equipment Setup for Frequency Calibration

1. Press CW F1 and set for the frequency shown below.

<u>Model</u>	<u>Frequency (GHz)</u>
6609A	0.050
6642A	18.050
All Others	2.050

2. Press CW F2 and set for the frequency shown below.

<u>Model</u>	<u>Frequency (GHz)</u>
6609A	1.950
6642A	26.450
All Others	7.950

3. Press CW F1; wait ≈ 10 s for the frequency to settle.

4. Using care to prevent the frequency from going below that shown in column 2 below, adjust A6R5 (A6R12 for 6609A) (Figure 5-24) for the frequency shown in column 3 below.

<u>Model</u>	<u>Low-End Frequency (GHz)</u>	<u>Adjustment Frequency (GHz)</u>
6609A	0.010	0.050 \pm 1 MHz
6642A	18.000	18.050 \pm 1 MHz
All Others	2.000	2.050 \pm 1 MHz

5. Press CW F2; wait ≈ 10 s for the frequency to settle.

6. Using care to prevent the frequency from going above the frequency shown in column 2 below, adjust A6R7 for the frequency shown in column 3 below.

<u>Model</u>	<u>High-End Frequency (GHz)</u>	<u>Adjustment Frequency (GHz)</u>
6609A	2.000	1.950 \pm 1 MHz
6642A	26.500	26.450 \pm 1 MHz
All Others	8.000	7.950 \pm 1 MHz

NOTE

In steps 4 and 6, if the frequency goes below the low-end frequency or above the high-end frequency, the adjustments are invalid. If this happens, repeat steps 1 thru 6.

7. Repeat steps 3 thru 6, as necessary, until the two frequencies are within tolerance.

8. Press FREQUENCY RANGE F1-F2.

9. Press MANUAL SWEEP and set the associated control fully counter-clockwise.

10. Adjust A6R3 for a counter reading, as indicated below:

<u>Model</u>	<u>Frequency (GHz)</u>
6609A	0.050 \pm 1 MHz
6642A	18.050 \pm 1 MHz
All Others	2.050 \pm 1 MHz

11. Press CW F0 and set for the frequency shown below:

<u>Model</u>	<u>Frequency (GHz)</u>
6609A	1.000
6642A	22.250
All Others	5.000



Figure 5-24. Osc 1 Frequency Adjustments

12. After the frequency has settled, observe and record the counter reading.
13. Press FREQUENCY VERNIER INCREASE and hold depressed until the frequency stops increasing.
14. Adjust A6R9 until the counter reads 12.7 ± 0.1 MHz (25 ± 0.1 MHz for 6642A, 6653A, and 6659A) above the frequency recorded in step 12.
15. Press FREQUENCY VERNIER OFF, and note that the counter reads the frequency recorded in step 12.
16. Press FREQUENCY VERNIER DECREASE and hold depressed until the frequency stops decreasing.
17. Verify that the counter reading decreased by 12.7 ± 0.1 MHz (25 ± 0.1 MHz for 6642A, 6653A, and 6659A) from the value recorded in step 12.
18. Press FREQUENCY VERNIER OFF.
19. Press FREQUENCY RANGE $\Delta F F0$.
20. Press ΔF and set for 0 MHz.
21. Using the FREQUENCY VERNIER pushbuttons, set the F0 frequency for the counter reading shown below:

<u>Model</u>	<u>Frequency (GHz)</u>
6609A	1.000
6642A	18.050
All Others	5.000

22. Press ΔF and set for 50 MHz.
23. Rotate the MANUAL SWEEP control between its clockwise and counter-clockwise ends and note the frequency at each end.
24. Adjust A10R10 on the FM/Attenuator PCB so that the frequency excursions from the step 24 frequency are equal, ± 0.5 MHz, at each end of the MANUAL SWEEP control range.

e. .01-2 GHz Band (Heterodyne) Frequency Calibration (Models 6617A, 6647A, 6648A, and 6659A)

1. Press CW F1 and set for 1 GHz.
2. Adjust A6R12 (Figure 5-24) for a counter reading of 1.000 GHz ± 1 MHz.
3. Press F1 and sequentially set the frequency for 0.010 GHz, then 2.000 GHz.
4. Verify that the counter reads 0.010 and 1.950 GHz ± 10 MHz, respectively, at each end of the band. If not, readjust A6R12 as necessary to achieve this frequency tolerance.

f. Osc 2 Frequency Calibration

CAUTION

To prevent misalignment due to being on the wrong side of the YIG oscillator's hysteresis curve, steps 1 thru 7 should be followed exactly as written.

1. Press RESET.
2. Press FREQUENCY RANGE F1-F2.
3. Press F1 and set for the frequency shown below.

<u>Model</u>	<u>Frequency (GHz)</u>
6642A	26.550
All Others	8.050

4. Press F2 and set for the frequency shown below.

<u>Model</u>	<u>Frequency (GHz)</u>
6642A	39.950
All Others	12.350

5. Press CW F1; wait ≈ 10 s for the frequency to settle.
6. Using care to prevent the frequency from going below that shown in col-

umn 2 below, adjust A7R2 (Figure 5-25) for the frequency shown in column 3 below.

<u>Model</u>	<u>Low-End Frequency (GHz)</u>	<u>Adjustment Frequency (GHz)</u>
6642A	26.500	26.550 ± 1 MHz
All Others	8.000	8.950 ± 1 MHz

7. Press CW F2; wait ≈ 10 s for the frequency to settle.
8. Using care to prevent the frequency from going above that shown in column 2 below, adjust A7R7 for the frequency shown in column 3 below.

<u>Model</u>	<u>High-End Frequency (GHz)</u>	<u>Adjustment Frequency (GHz)</u>
6642A	40.000	39.950 ± 1 MHz
All Others	12.400	12.350 ± 1 MHz

NOTE

In steps 6 and 8, if the frequency goes below the low-end frequency or above the high-end frequency, the adjustments are invalid. If this happens, repeat steps 2 thru 8.

9. Repeat steps 5 thru 8, as necessary, until the two frequencies are within tolerance.
10. Press FREQUENCY RANGE F1-F2.
11. Press MANUAL SWEEP and set the associated control fully counter-clockwise.
12. Adjust A7R5 for a counter reading as indicated below:

<u>Model</u>	<u>Frequency (GHz)</u>
6642A	26.050 ± 1 MHz
All Others	8.050 ± 1 MHz

13. Press CW F0, and set for the frequency shown below:

<u>Model</u>	<u>Frequency (GHz)</u>
6642A	22.250
All Others	10.000

14. After the frequency has settled, observe and record the counter reading.
15. Press FREQUENCY VERNIER INCREASE and hold depressed until the frequency stops increasing.
16. Adjust A7R9 until the counter reads 12.7 ± 0.1 MHz (25 ± 0.1 MHz for 6642A, 6653A, 6659A) above the frequency recorded in step 14.
17. Press FREQUENCY VERNIER OFF, and note that the counter reads the frequency recorded in step 14.
18. Press FREQUENCY VERNIER DECREASE and hold depressed until the frequency stops decreasing.
19. Verify that the counter reading decreased by 12.7 ± 0.1 MHz (25 ± 0.1 MHz for 6642A, 6653A, 6659A) from the value recorded in step 14.
20. Press FREQUENCY VERNIER OFF.
21. Press FREQUENCY RANGE $\Delta F F0$.
22. Press ΔF and set for 0 MHz.
23. Using the FREQUENCY VERNIER pushbuttons, set the F0 frequency for the counter reading shown below:

<u>Model</u>	<u>Frequency (GHz)</u>
6642A	22.250
All Others	10.000

24. Press ΔF and set for 50 MHz.
25. Rotate the MANUAL SWEEP control between its clockwise and counter-clockwise ends and note the frequency at each end.
26. Adjust A10R11 on the FM/Attenuator PCB so that the frequency excursions from the step 23 frequency are equal, ± 0.5 MHz, at each end of the MANUAL SWEEP control range.

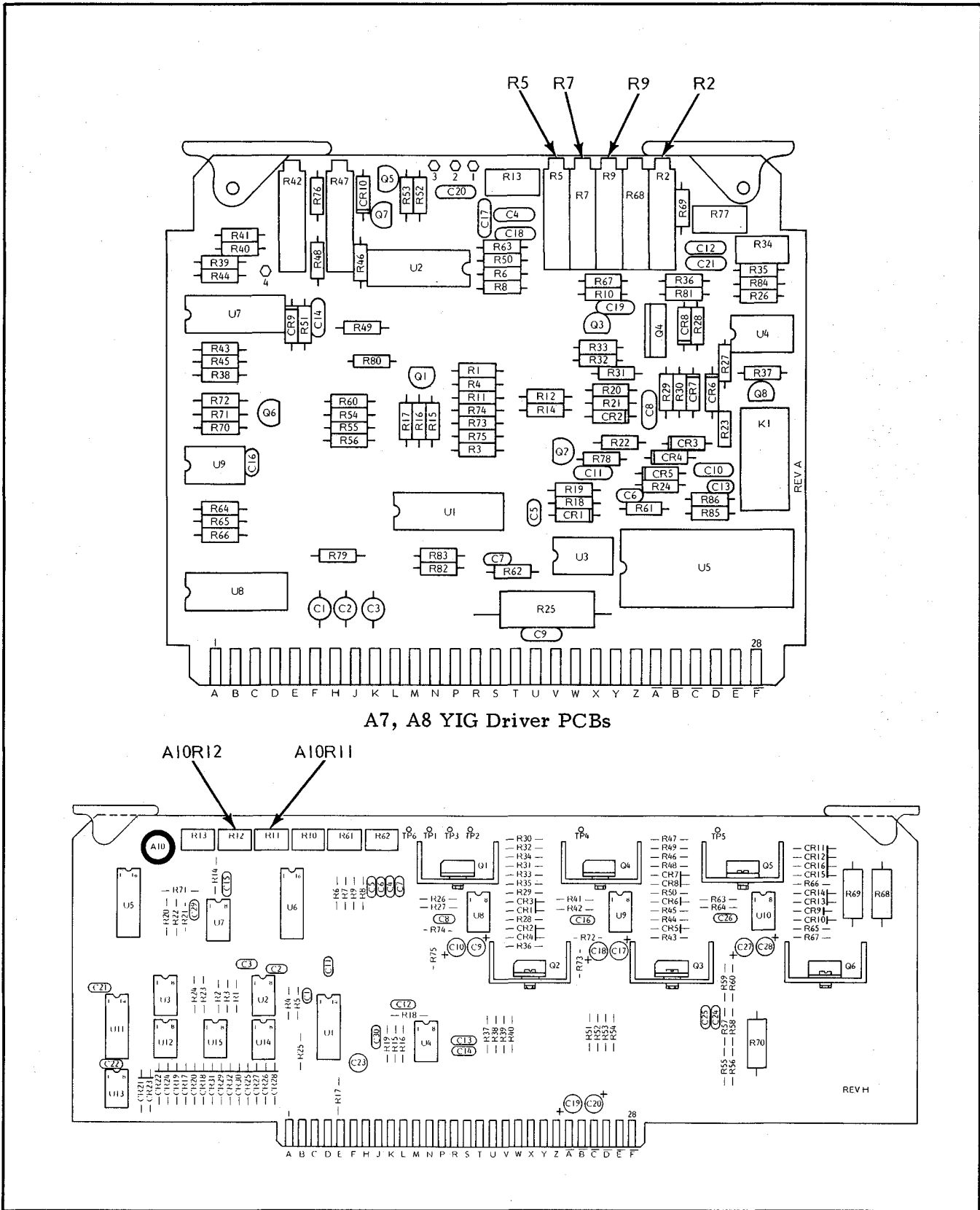

Figure 5-25. 8-12.4 and 12.4-18.6 (or 20) GHz Band (Osc 2 and 3) Frequency Adjustments

g. Osc 3 Frequency Calibration

CAUTION

To prevent misalignment due to being on the wrong side of the YIG oscillator's hysteresis curve, steps 1 thru 7 should be followed exactly as written.

1. Press RESET.
2. Press FREQUENCY RANGE F1-F2.
3. Press F1 and set for 12.450 GHz.
4. Press F2 and set for the frequency shown below.

<u>Model</u>	<u>Frequency (GHz)</u>
6638A/6648A	19.950
6653A/6659A	17.950
6637A/6647A	18.550

5. Press CW F1; wait ≈ 10 s for the frequency to settle.
6. Using care to prevent the frequency from going below 12.400 GHz, adjust A8R2 (Figure 5-25) for 12.450 GHz ± 1 MHz, as indicated on the counter.
7. Press CW F2; wait ≈ 10 s for the frequency to settle.
8. Using care to prevent the frequency from going above that shown in column 2 below, adjust A8R7 for the frequency shown in column 3 below:

<u>Model</u>	<u>High-End Frequency (GHz)</u>	<u>Adjustment Frequency (GHz)</u>
6638A/6648A	20.000	19.950 ± 1 MHz
6653A/6659A	18.000	17.950 ± 1 MHz
6637A/6647A	18.600	18.550 ± 1 MHz

NOTE

In steps 6 and 8, if the frequency goes below the low-end frequency or above the high-end frequency, the adjustments are invalid. If this happens,

repeat steps 5 thru 8.

9. Repeat steps 5 thru 8, as necessary, until the two frequencies are within tolerance.
10. Press FREQUENCY RANGE F1-F2.
11. Press MANUAL SWEEP and set the associated control fully counter-clockwise.
12. Adjust A8R5 for a reading of 12.450 GHz ± 1 MHz, as indicated on the counter.
13. Press CW F0, and set for 15 GHz.
14. After the frequency has settled, observe and record the counter reading.
15. Press FREQUENCY VERNIER INCREASE and hold depressed until the frequency stops increasing.
16. Adjust A8R9 until the counter reads 12.7 ± 0.1 MHz (25 ± 0.1 MHz for 6653A and 6659A) above the frequency recorded in step 14.
17. Press FREQUENCY VERNIER OFF, and note that the counter reads the frequency recorded in step 14.
18. Press FREQUENCY VERNIER DECREASE and hold depressed until the frequency stops decreasing.
19. Verify that the counter reading decreased by 12.7 ± 0.1 MHz (25 ± 0.1 MHz for 6653A and 6659A) below the value recorded in step 14.
20. Press FREQUENCY VERNIER OFF.
21. Press FREQUENCY RANGE ΔF F0.
22. Press ΔF and set for 0 MHz.
23. Using the FREQUENCY VERNIER pushbuttons, set the F0 frequency for a counter reading of 15.000 GHz.
24. Press ΔF and set for 50 MHz.

25. Rotate the MANUAL SWEEP control between its clockwise and counter-clockwise ends and note the frequency at each end.
26. Adjust A10R12 on the FM/Attenuator PCB so that the frequency excursions from 15 GHz are equal, ± 0.5 MHz, at each end of the MANUAL SWEEP control.

h. Osc 4 Frequency Calibration

CAUTION

To prevent misalignment due to being on the wrong side of the YIG oscillator's hysteresis curve, steps 1 thru 8 should be followed exactly as written.

1. Press RESET.
2. Press FREQUENCY RANGE F1-F2.
3. Press F1 and set for 18.050 GHz.
4. Press F2 and set for 26.450 GHz.
5. Press CW F1; wait ≈ 10 s for the frequency to settle.
6. Using care to prevent the frequency from going below 18.000 GHz, adjust A8R2 (Figure 5-25) for 18.050 GHz ± 1 MHz, as indicated on the counter.
7. Press CW F2; wait ≈ 10 s for the frequency to settle.
8. Using care to prevent the frequency from going above 26.500 GHz, adjust A8R7 for 26.450 GHz ± 1 MHz, as indicated on the counter.

NOTE

In steps 6 and 8, if the frequency goes below 18.000 or above 26.500 GHz, the adjustments are invalid. If this happens, repeat steps 5 thru 8.

9. Repeat steps 5 thru 8, as necessary,

until the two frequencies are within tolerance.

10. Press FREQUENCY RANGE F1-F2.
11. Press MANUAL SWEEP and set the associated control fully counter-clockwise.
12. Adjust A8R5 for a reading of 18.050 GHz ± 1 MHz, as indicated on the counter.
13. Press CW F0, and set for 22.250 GHz.
14. After the frequency has settled, observe and record the counter reading.
15. Press FREQUENCY VERNIER INCREASE and hold depressed until the frequency stops increasing.
16. Adjust A8R9 until the counter reads 25.0 ± 0.1 MHz above the frequency recorded in step 14.
17. Press FREQUENCY VERNIER OFF, and note that the counter reads the frequency recorded in step 14.
18. Press FREQUENCY VERNIER DECREASE and hold depressed until the frequency stops decreasing.
19. Verify that the counter reading decreased by 25.0 ± 0.1 MHz below the value recorded in step 14.
20. Press FREQUENCY VERNIER OFF.
21. Press FREQUENCY RANGE ΔF F0.
22. Press ΔF and set for 0 MHz.
23. Using the FREQUENCY VERNIER pushbuttons, set the F0 frequency for a counter reading of 15.000 GHz.
24. Press ΔF and set for 50 MHz.
25. Rotate the MANUAL SWEEP control between its clockwise and counter-clockwise ends and note the frequency at each end.

26. Adjust A10R13 on the FM/Attenuator PCB so that the frequency excursions from 22.250 GHz are equal, ± 0.5 MHz, at each end of the MANUAL SWEEP control range.

5-10 2-8 GHz BAND (OSC 1) TRACKING FILTER ADJUSTMENTS (Models 6617A, 6647A, 6648A, and 6659A)

This paragraph provides instructions for adjusting the 2-8 GHz band (Osc 1) tracking filter. These adjustments should be performed following maintenance on the A6 PCB or when the power output of the sweep generator is below its specified tolerance in the 2-8 GHz band.

- a. Connect test equipment as shown in Figure 5-26, and turn the equipment on.
- b. Remove the top cover from the sweep generator (sweeper). Refer to paragraph 7-3.1 for instructions, if necessary.
- c. Press RESET on sweeper.

- d. Press FREQUENCY RANGE F1-F2.
- e. Press F1 and set for 2 GHz.
- f. Press F2 and set for 8 GHz.
- g. Press INTERNAL leveling to the off position (indicator not lit).
- h. On the network analyzer,
 - 1. press Channel A REF POS LOCATE and adjust the associated SET potentiometer so that the reference line is positioned on the display's center graticule line;
 - 2. release REF POS LOCATE;
 - 3. a trace similar to that shown in Figure 5-27 should be observed.
- i. On the sweeper,
 - 1. alternately adjust A6R36 and A6R38 (Figure 5-31) to obtain maximum out-

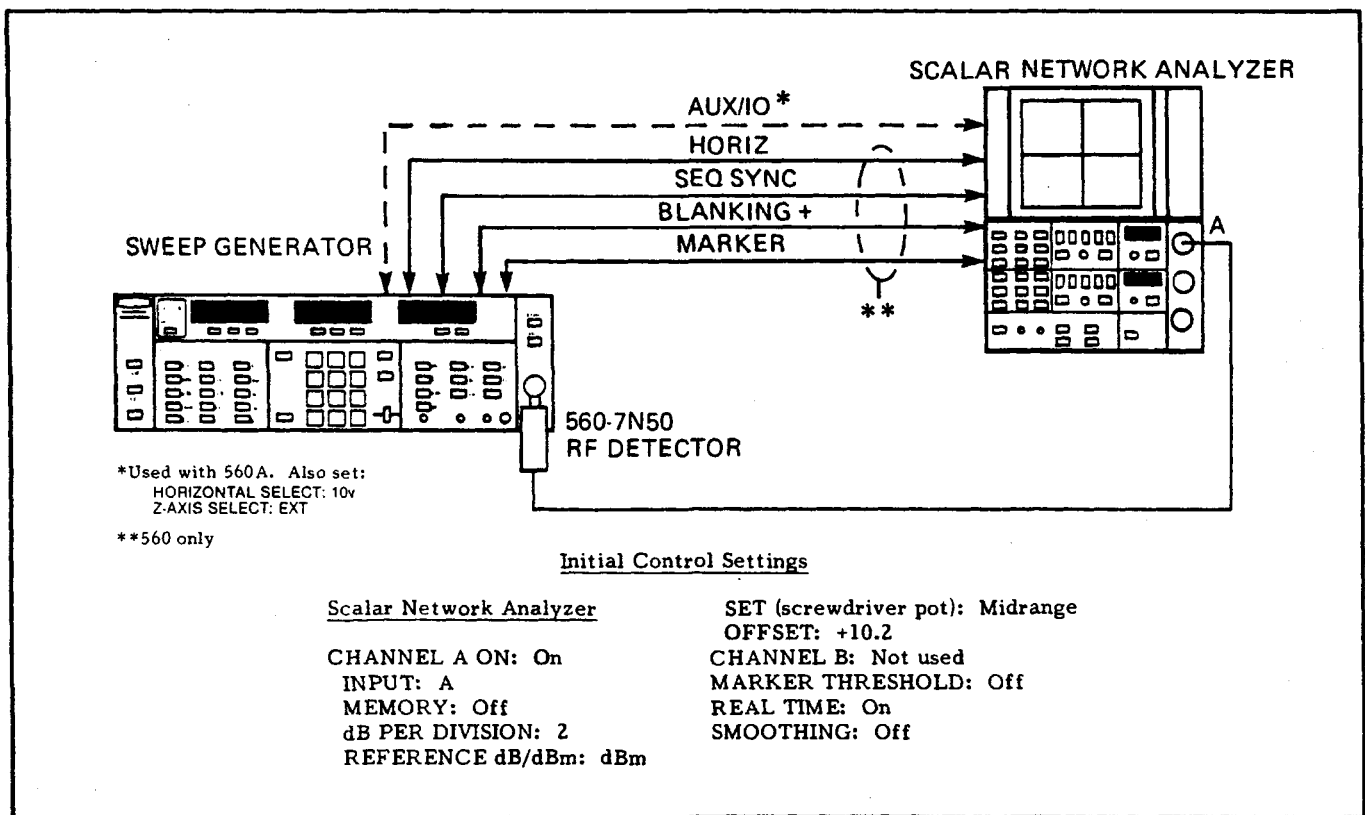

Figure 5-26. Test Equipment Setup for Tracking Filter Adjustments

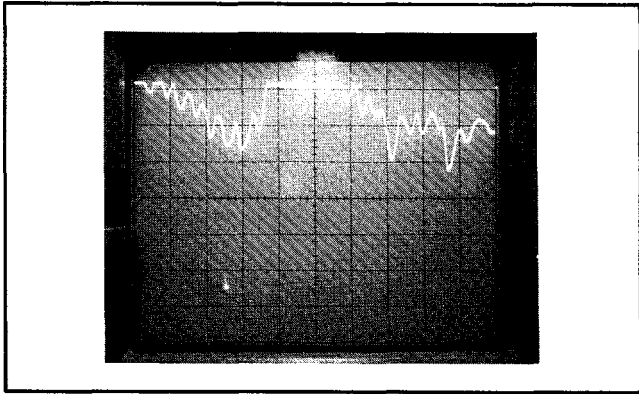

Figure 5-27. F1-F2 Sweep, Unleveled Power

put power across the frequency band. A6R36 will adjust power at the low and A6R38 at the high end of the frequency band;

2. press INTERNAL leveling;
 3. press FULL.
- j. On the network analyzer, press Channel A .2 dB PER DIVISION.
- k. On the sweeper,
1. press LEVEL;
 2. operate the INCREASE/DECREASE lever to place the minimum-power point of the displayed trace (Figure 5-28) on the center graticule line.

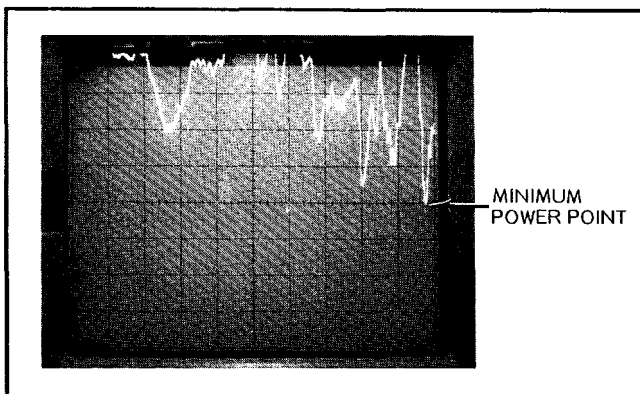

Figure 5-28. Minimum Power Point on Leveled Output Power Signal

3. press ΔF F0;
4. press ΔF and set for 50 MHz;
5. press F0 and set for 2.000 GHz.

1. On network analyzer, press Channel A .5 dB PER DIVISION. The trace should appear on the top half of the display (Figure 5-29).

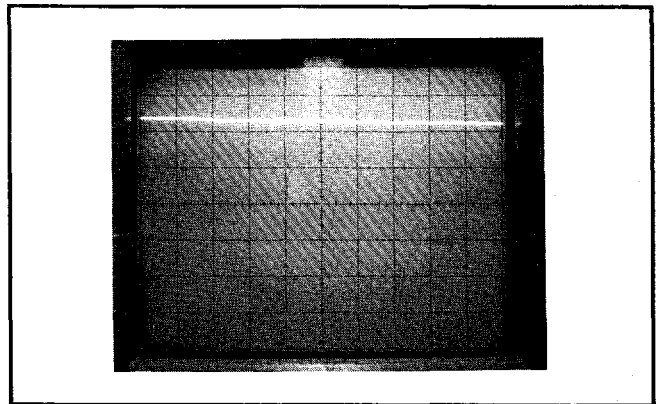

Figure 5-29. Narrow-Band Sweep, Leveled Power

- m. On sweeper, move the INCREASE/DECREASE lever toward INCREASE so that the F0 frequency slowly advances, as indicated on the LED numeric display.
- n. Observe the network analyzer display and ensure that the trace does not go unleveled (Figure 5-30) at any frequency between 2 and 8 GHz.

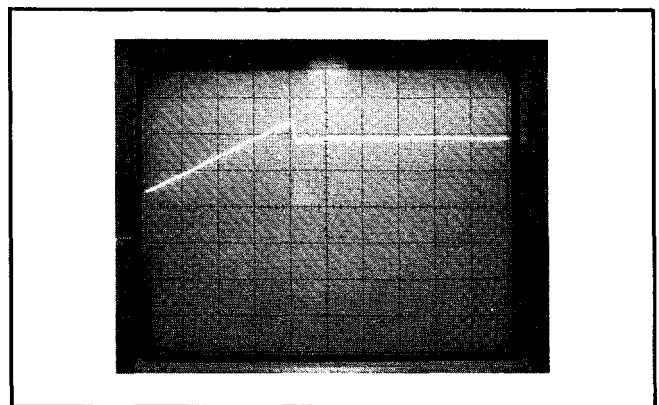

Figure 5-30. Narrow-Band Sweep, Unleveled Power

- o. If the trace goes unleveled, adjust A10R62 until it becomes leveled (Figure 5-29).
- p. Using the INCREASE/DECREASE lever, recheck the ΔF F0 narrow-band sweep and ensure that it has leveled power at all frequencies between 2 and 8 GHz.

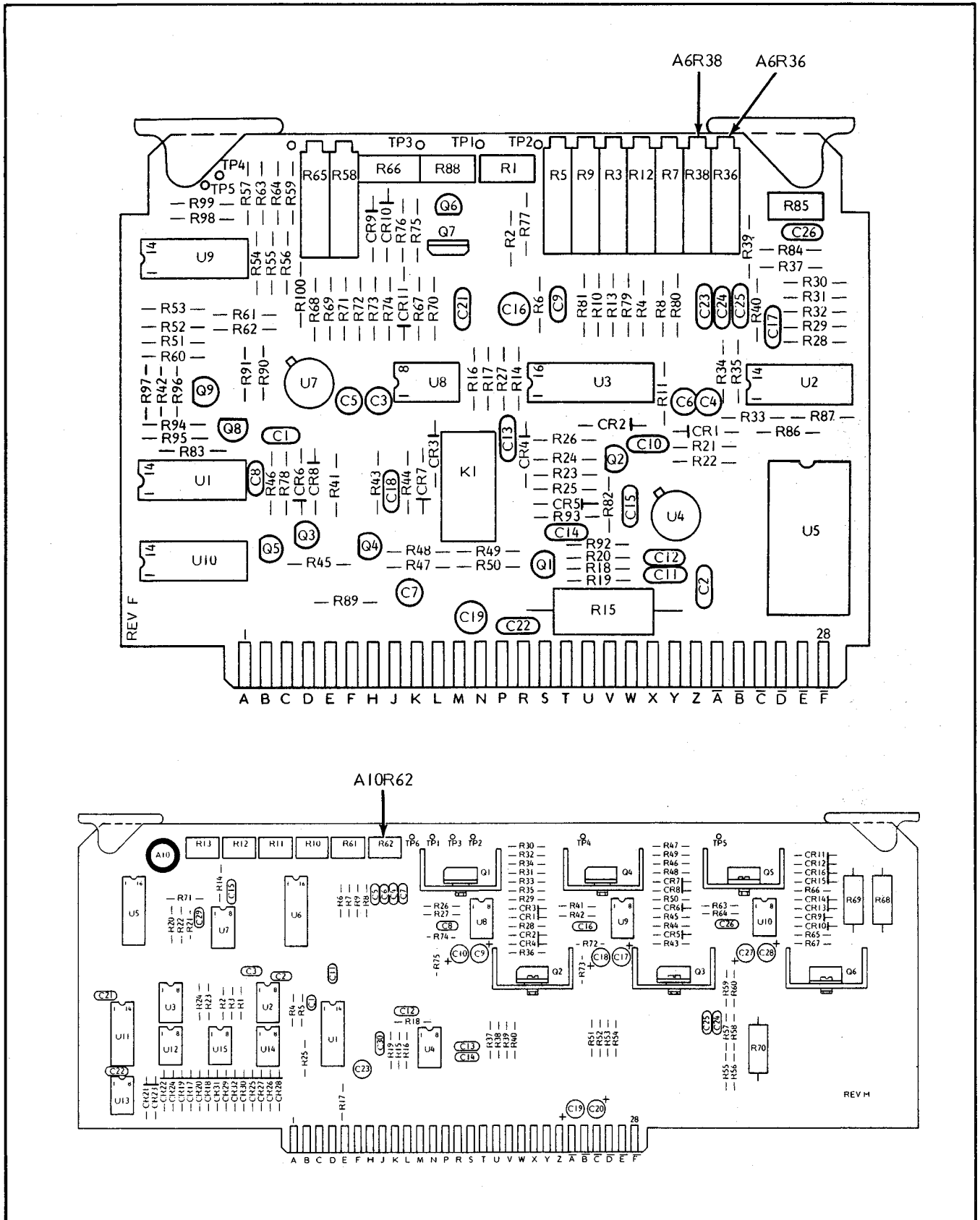

Figure 5-31. Tracking Filter Adjustments

5-11 SWEEP RATE COMPENSATION ADJUSTMENT

This paragraph provides instructions for adjusting the sweep generator so that the frequency shift is minimum when the sweep rate is varied. This adjustment should be performed following maintenance on any of the A6-A9 PCBs, or when a frequency shift is detected while increasing or decreasing sweep speed.

- a. Connect the test equipment as shown in Figure 5-33, and turn the equipment on.
- b. Remove the top cover from the sweep generator (sweeper). Refer to paragraph 7-3.1 for instructions, if necessary.
- c. Press RESET.
- d. Press INTERNAL leveling to off (indicator not lit).
- e. Press SWEEP TIME and set for 10 ms.
- f. Adjust oscilloscope vertical control to obtain a waveform similar to that shown in Figure 5-32.

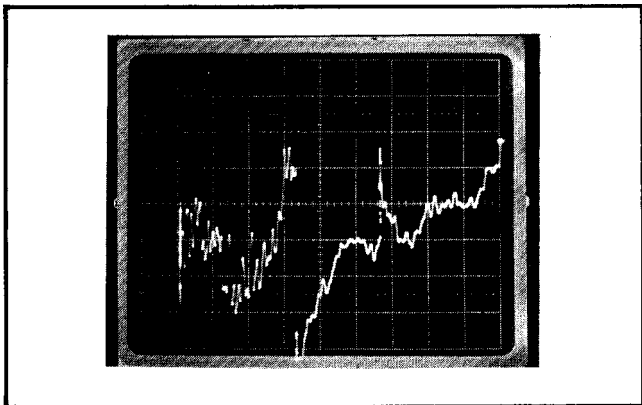

Figure 5-32. Model 6647A Unleveled Full-Band Sweep

- g. While monitoring the oscilloscope,
 1. select a perturbation to observe in the Osc 1 (2-8 GHz) band (Figure 5-34),
 2. alternately change the SWEEP TIME between 10 and 30 ms, and

3. adjust A6R1 (Figure 5-35) for a minimum frequency shift, as indicated by the selected perturbation.

- h. Repeat step g. for the applicable Osc 2, Osc 3, and Osc 4 YIG bands. Adjust A7R13 for Osc 2, A8R13 for Osc 3, and A9R13 for Osc 4.

5-12 ALC LOOP CALIBRATION

This paragraph provides instructions for calibrating the sweep generator's ALC (automatic level control) loop. The procedure in paragraph 5-12.1 covers all models except the 26.5 to 40 GHz band of the 6642A. This band is covered in paragraph 5-12.2. The ALC loop calibration procedures should be performed following the repair or replacement of any of the ALC loop components.

5-12.1 ALC Loop Adjustments (All Models Except 6642A, 26.5 to 40 GHz Band)

This paragraph describes the ALC loop adjustments, which are divided into four groups: ALC Bandwidth, RF Slope, Power Level, and Coupler/Het detector Tracking for Models 6617A, 6647A, 6648A, and 6659A.

a. ALC Loop Bandwidth Adjustments

1. Set up the test equipment as shown in Figure 5-36, and turn the equipment on.
2. Remove the top cover from the sweep generator (sweeper). Refer to paragraph 7-3.1 for instructions, if necessary.
3. Adjust the function generator to supply the sweeper with a 10 kHz, 0-10V square wave.
4. Press RESET on sweeper.
5. Het Band (A4/A6 PCBs) Loop Adjustment (Models 6609A, 6617A, 6647A, 6648A, and 6659A)
 - (a) Press CW F1 and set for 1.000 GHz.

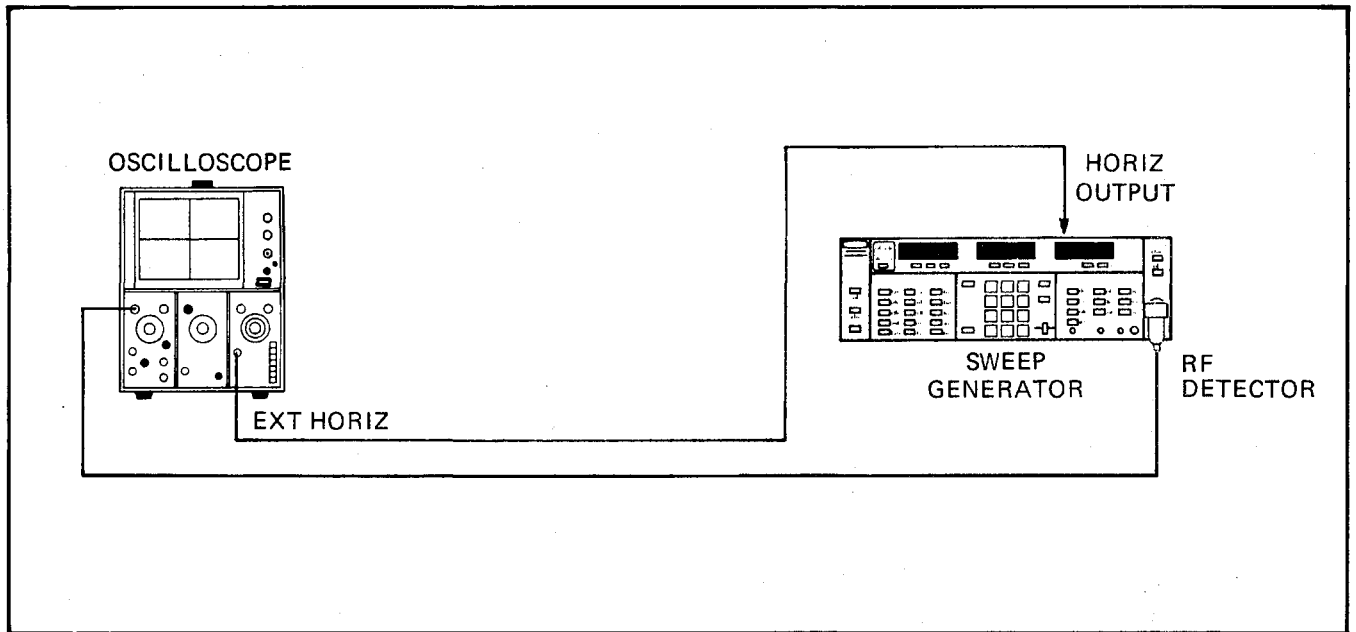

Figure 5-33. Test Equipment Setup for Sweep Rate Compensation Adjustments

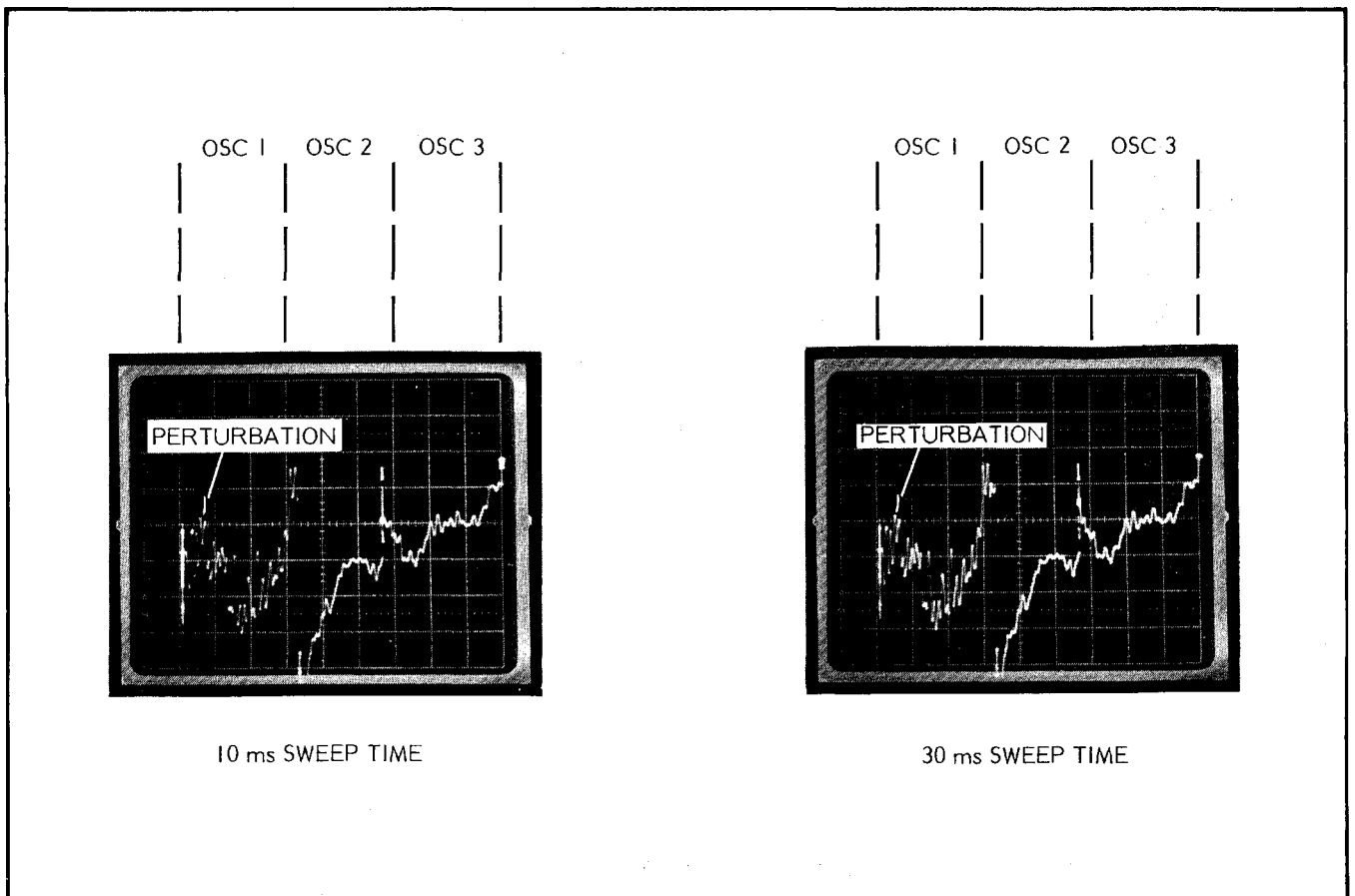

Figure 5-34. Waveforms Showing Frequency Shift with Sweep Time Change

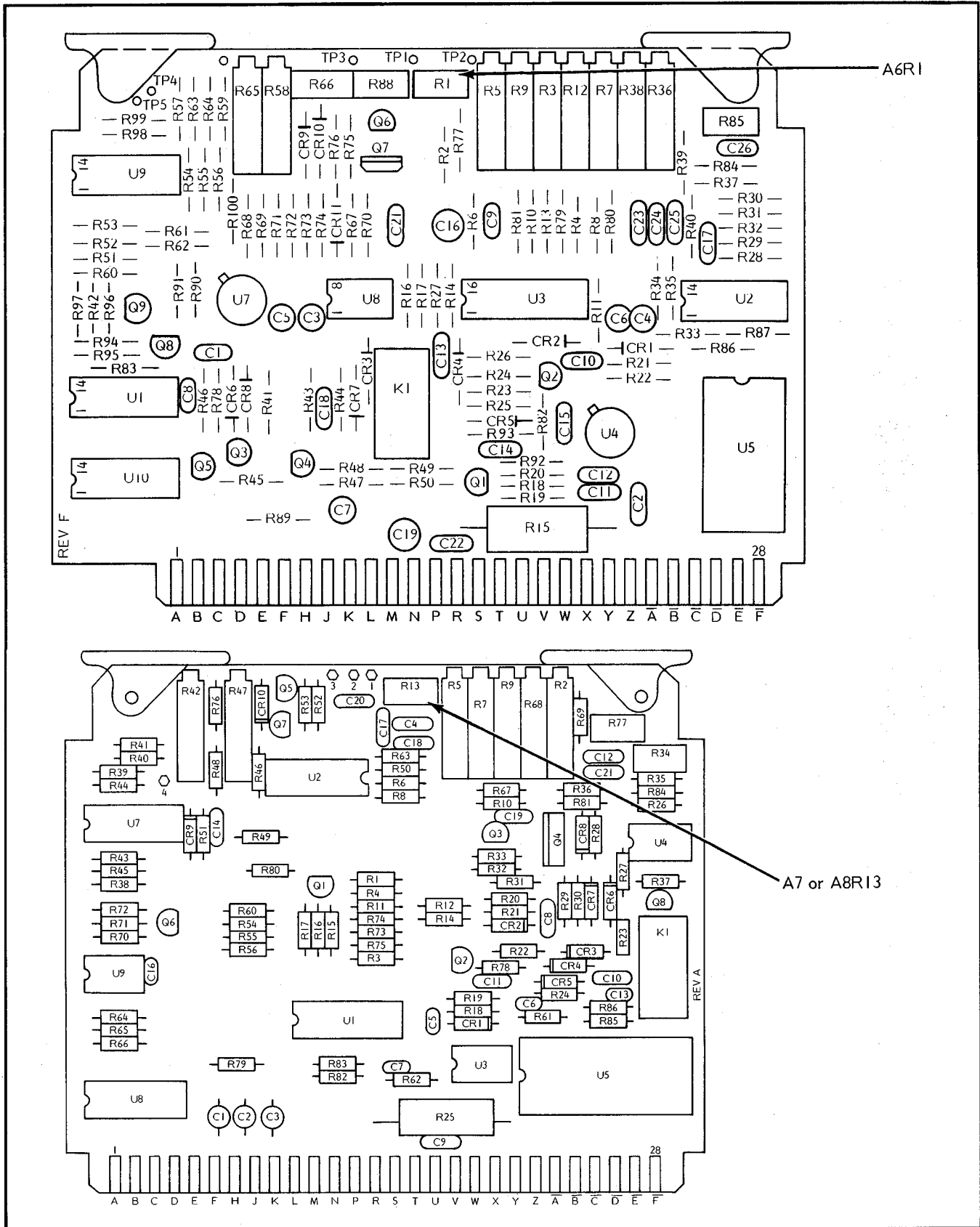

Figure 5-35. Sweep Rate Compensation Adjustments

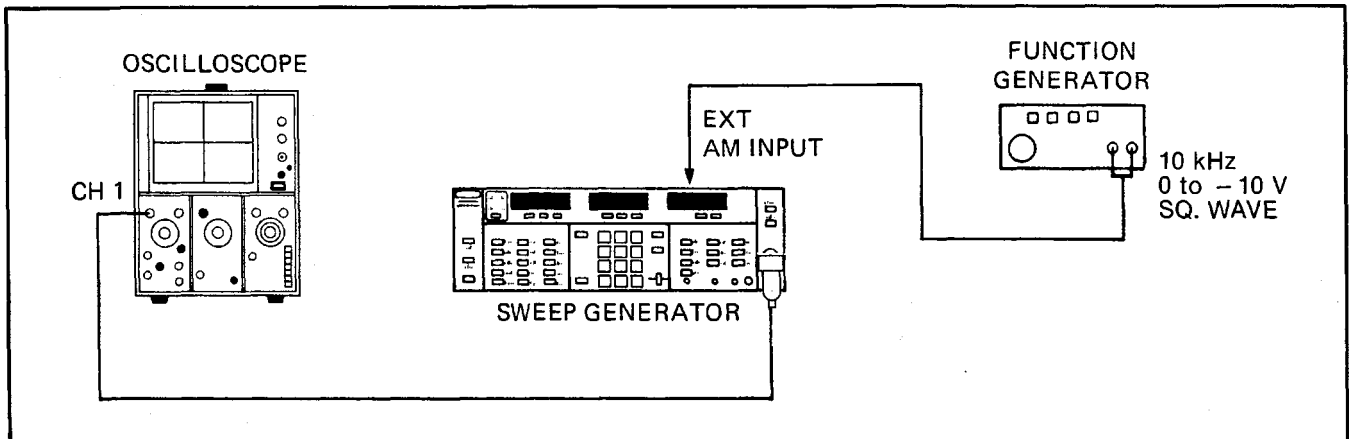

Figure 5-36. Test Equipment Setup for Making ALC Loop Bandwidth Adjustments

- (b) Adjust the oscilloscope vertical and horizontal controls to display a square wave similar to that shown in Figure 5-37.

NOTE

Ensure that the UNLEVELED indicator is not lit, which may happen if the square wave is riding a dc offset.

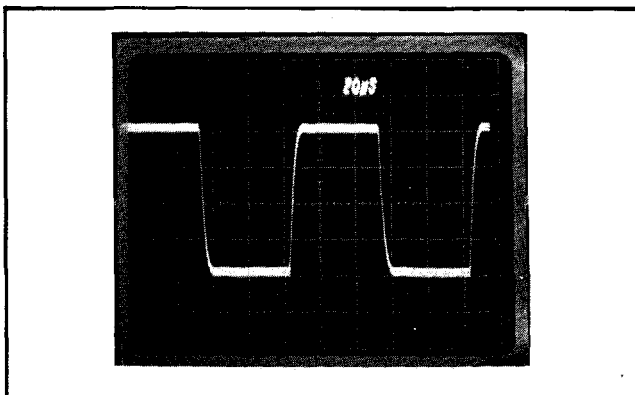

Figure 5-37. ALC Loop Square Wave

- (c) Adjust A4R124 and A6R66 (Figure 5-38) for a square wave with no overshoot and a rise time of less than 20 μ s.
- (d) For 6609A, go to step 11; for all other models, go to step 6.
6. Osc 1 (A4/A6 PCBs) Loop Adjustment (All models except 6609A, 6629A and 6629A-40)*

*For 6629A and 6629A-40, go to step 7.

- (a) Press CW F1 and set as shown below:

Model	Frequency (GHz)
6642A	22.250
All Others	5.000

- (b) Adjust the oscilloscope vertical and horizontal controls to display a square wave similar to that shown in Figure 5-37.

NOTE

Ensure that the UNLEVELED indicator is not lit, which may happen if the square wave is riding a dc offset.

- (c) Adjust A4R123 and A6R66 (Figure 5-36) for a square wave with no overshoot and a rise time of less than 20 μ s.
- (d) For 6617A, go to step 11; for 6642A go to paragraph 5-12.2; and for all other models, go to step 8.

7. Osc 2 (A4/A7 PCBs) Loop Adjustment (Models 6629A and 6629A-40)

- (a) Press CW F1 and set for 10 GHz.

NOTE

Ensure that the UNLEVELED indicator is not lit, which may happen if the square wave is riding a dc offset.

- (b) Adjust the oscilloscope vertical and horizontal controls to dis-

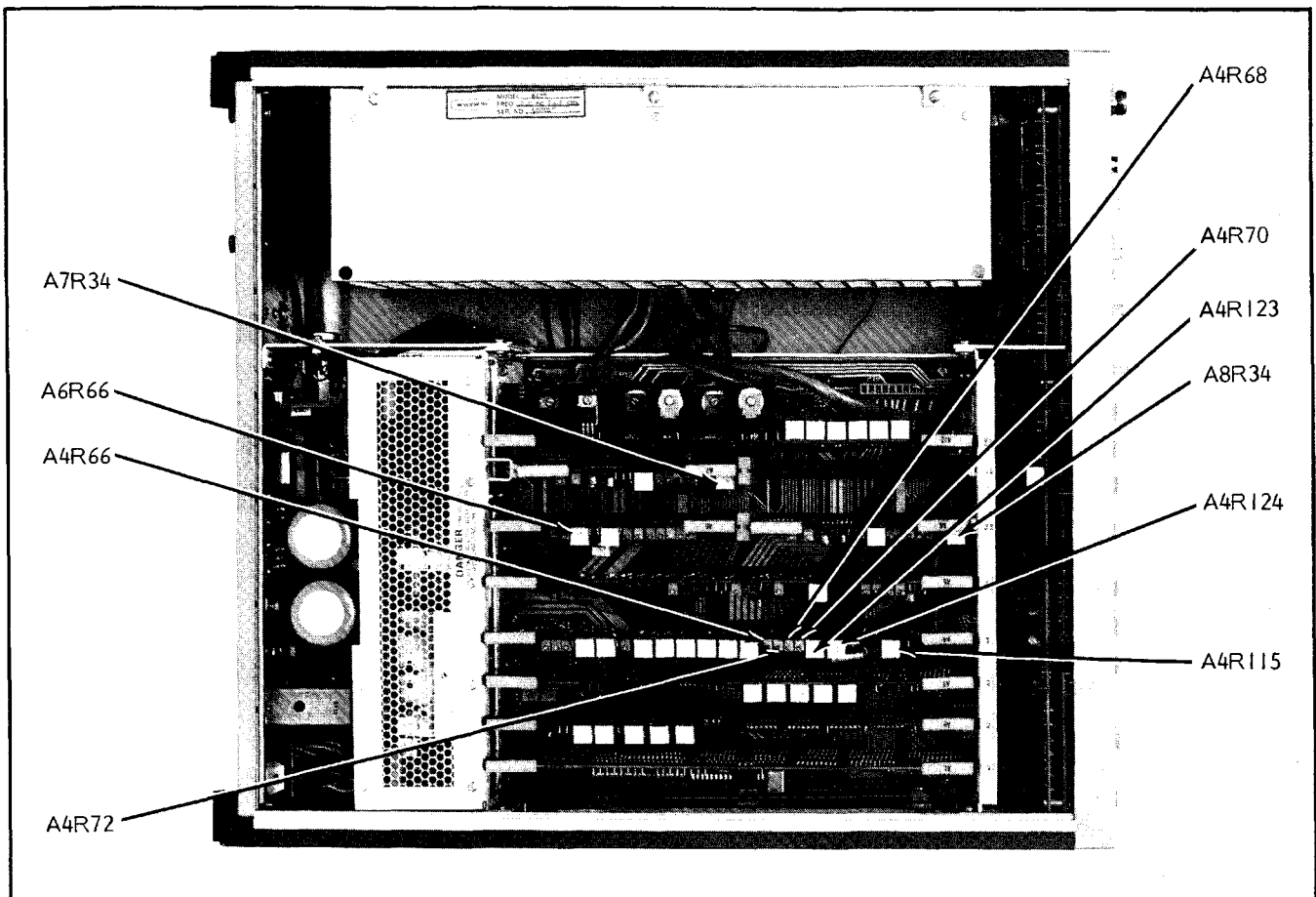

Figure 5-38. ALC Loop Adjustments

play a square wave similar to that shown in Figure 5-37.

- (c) Adjust A4R123 and A7R34 (Figure 5-38) for a square wave with no overshoot and a rise time of less than 20 μ s.

8. Osc 2 (A7 PCB) Loop Adjustment (All models except 6609A, 6617A, 6629A, and 6629A-40)

- (a) Press F1 and set for 10.000 GHz.
- (b) Adjust A7R34 for the best square-wave response.
- (c) For 6621A and 6621A-40, go to step 11; for all other models, go to step 9.

9. Osc 3 (A8 PCB) Loop Adjustment (Models 6629A, 6629A-40, 6637A, 6637A-40, 6638A, 6647A, 6648A, 6653A, and 6659A)

- (a) Press F1 and set for 15 GHz.
- (b) Adjust A8R34 for a square wave with no overshoot and a rise time of less than 20 μ s.
- (c) For all models except 6653A and 6659A, go to step 11; for these two models, go to step 10.

10. Osc 4 (A9 PCB) Loop Adjustment (Models 6653A and 6659A)

- (a) Press F1 and set for 22.25 GHz.
- (b) Press LEVEL and set for -1 dBm.
- (c) Adjust A9R34 for a square wave with no overshoot and a rise time of less than 20 μ s.
- (d) Go to step 11.

- 11. Press POWER to OFF, and disconnect the test equipment.

b. RF SLOPE Adjustment (All models except 6642A)*

1. Set up the test equipment as shown in Figure 5-39, and turn the equipment on.

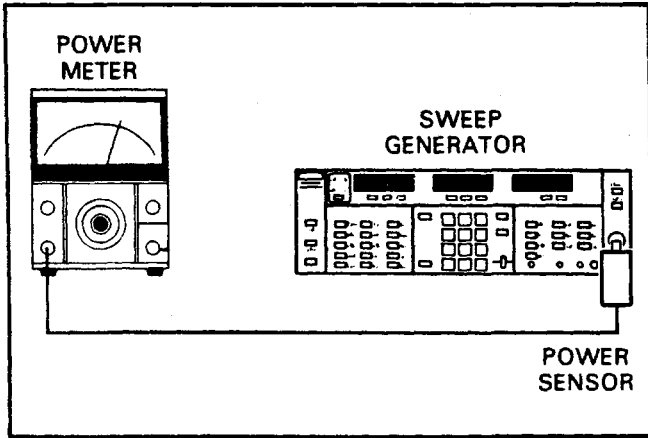

Figure 5-39. Test Equipment Setup for RF SLOPE and Power Level Adjustments

NOTE

Ensure that the RF SLOPE control is OFF.

2. Press RESET.
3. Press LEVEL and set for 5 dB below the power level indicated on the LEVEL LED display.
4. Press CW F1 and set as shown below:

Model	Frequency (GHz)
6609A	0.050
6629A and 6629A-40	8.050
All Others	2.050

5. Record the power meter reading.

NOTE

Ensure that the CAL FACTOR control on the power is set correctly for the frequency to be measured.

*The RF slope adjustment for the 6642A is described in paragraph 5-12.2.

**The power level adjustments for the 6642A are described in paragraph 5-12.1

6. Press CW F2 and set as shown below:

Model	Frequency (GHz)
6609A	1.950
6617A	7.950
6621A and 6621A-40	12.350
6629A, 6629A-40, 6637A, 6637A-40, and 6647A	18.550
6638A and 6648A	19.950
6653A and 6659A	26.450

7. Record the power meter reading.
8. Alternately press CW F1 and CW F2, and adjust A4R115 (Figure 5-38) for equal power at each CW frequency.

c. Power Level Adjustments (All models except 6642A)**

1. Press RESET.
2. Press F1 and set as shown below:

Model	Frequency (GHz)
6609A	0.050
6629A and 6629A-40	8.050
All Others	2.050

3. As indicated on the power meter, adjust A4R66 (Figure 5-38) for the power level indicated on the LEVEL LED display.
4. Press LEVEL and set for 9.9 dB below the power level indicated on the LEVEL LED display.
5. Adjust A4R72 for the power level indicated on the LEVEL LED display.
6. Repeat steps 2 thru 5 as necessary until the steps 2 and 4 power levels are ± 0.1 dB.
7. Press POWER to OFF, and disconnect the test equipment.

d. Coupler and Het Detector Tracking Adjustment (Models 6617A, 6647A, 6648A and 6659A)

1. Set up the test equipment as shown in Figure 5-40, and turn the equipment on.
2. On the sweeper,
 - (a) press FREQUENCY RANGE ΔF F0;
 - (b) press F0 and set for 1 GHz;
 - (c) press ΔF and set for 1 GHz.
3. On the network analyzer, press REF POS LOCATE, and adjust the SET screwdriver potentiometer to position the reference line to center-screen.
4. On the sweeper,
 - (a) press LEVEL and set for 10 dBm;
 - (b) Adjust A4R142 for a level trace on the network analyzer;
 - (c) press F0 and set for 2 GHz.
 - (d) adjust A4R68 until the power levels on both sides of the 2 GHz center frequency are approxi-

mately equal, as observed on the network analyzer.

5. On the network analyzer, readjust the OFFSET control for a 0 dBm reading on the OFFSET dB display.
6. On the sweeper,
 - (a) press LEVEL and set for 0 dBm.
 - (b) adjust A4R70 until the power levels on both sides of the 2 GHz center frequency are approximately equal, as observed on the network analyzer.

NOTE

If unable to obtain equal traces with A4R70 (above), adjust the A4U4 offset potentiometer (Figure 5-41); then readjust A4R70 as described above.

7. While observing the network analyzer display and using the 560 OFFSET control to keep the trace on the screen, use the INCREASE/DECREASE lever on the sweeper to vary the power level back and forth between 0 and 10 dBm.

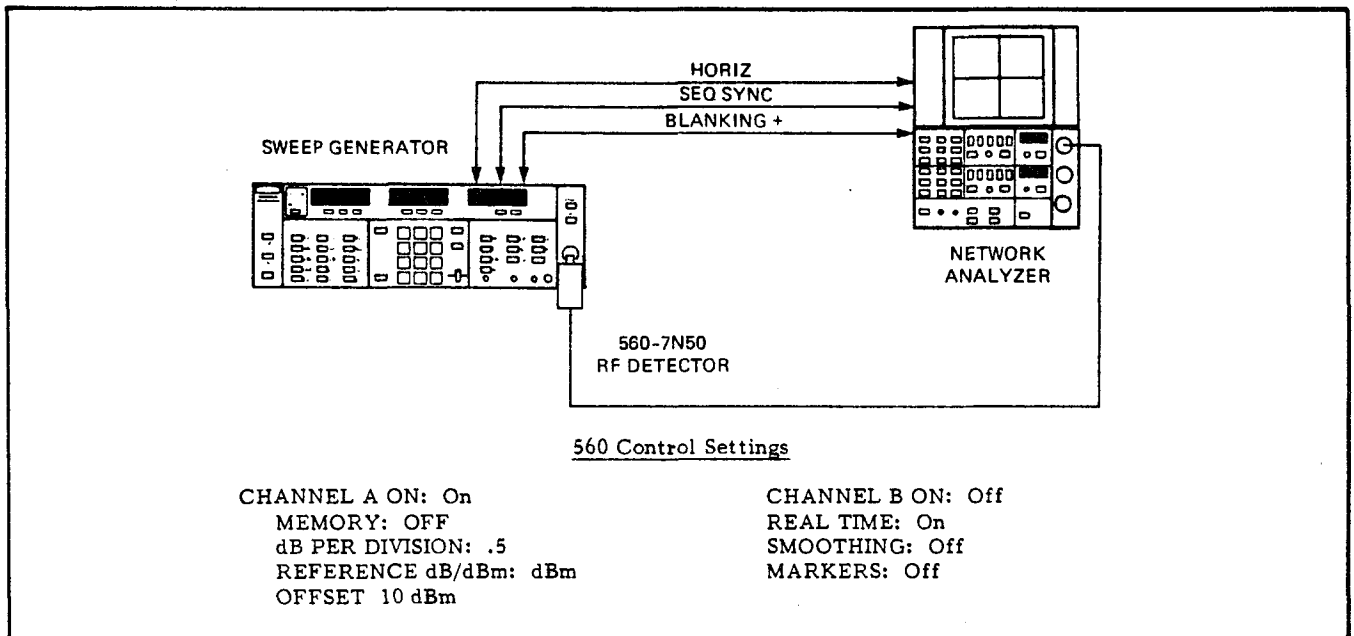

Figure 5-40. Test Equipment Setup for Detector Tracking Adjustment

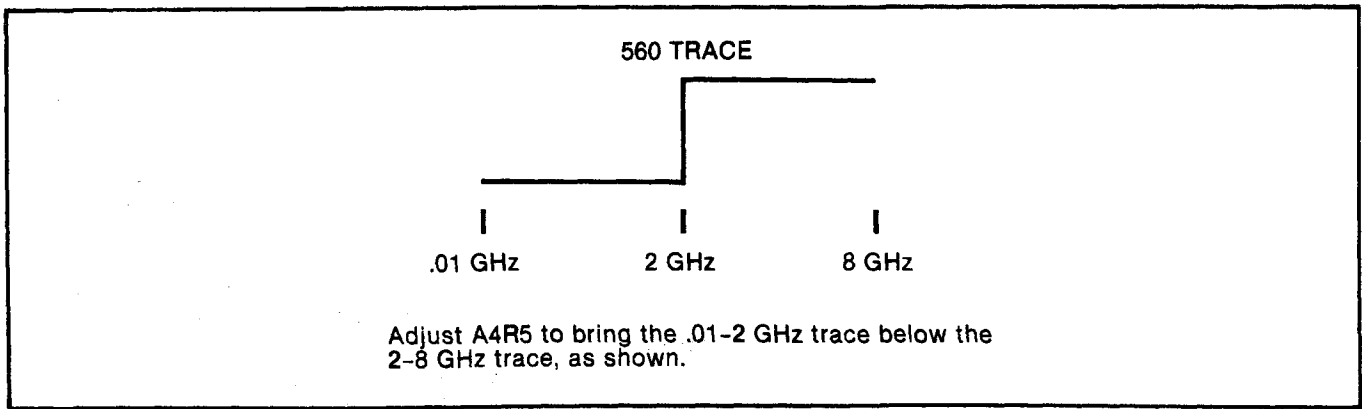

Figure 5-41. Potentiometer A4R5 Adjustments

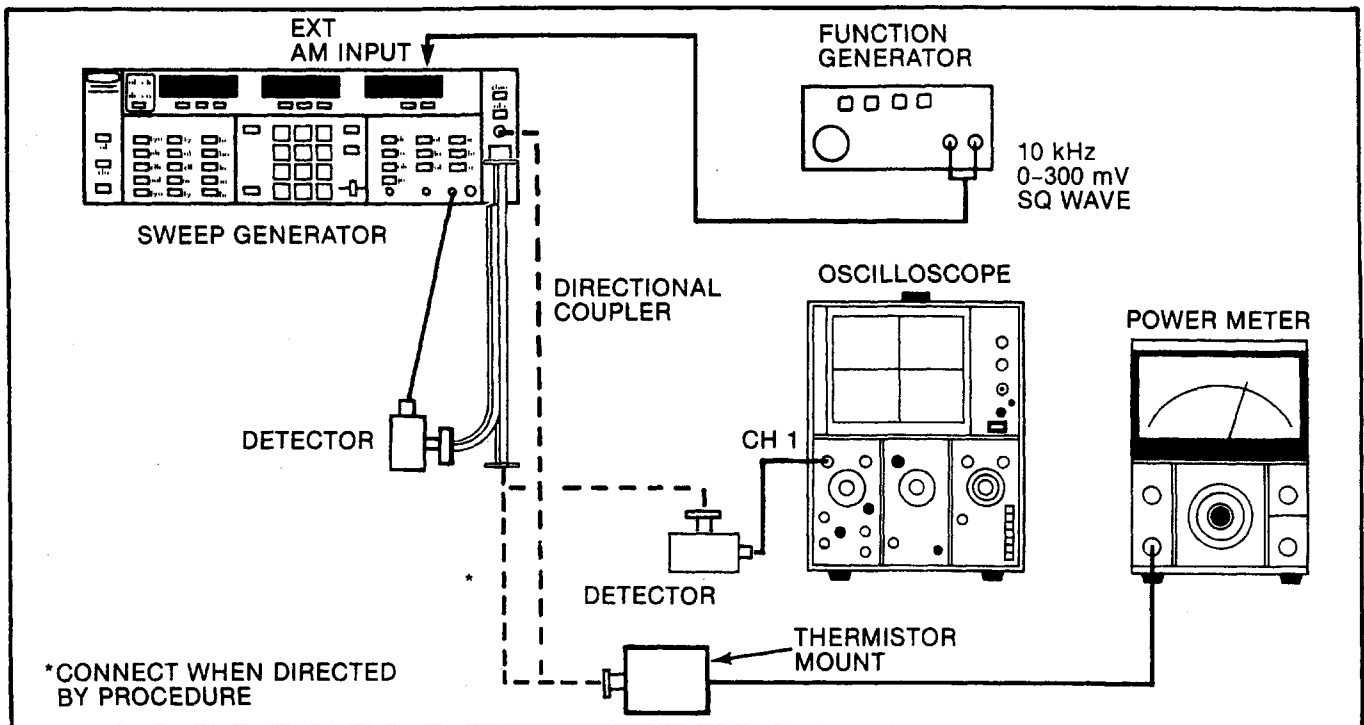

Figure 5-42. Model 6642A, Test Equipment Setup for Making ALC Loop Calibration Adjustments

8. Verify that the power levels on both sides of the 2 GHz center frequency are equal, ± 0.5 dB. If they are unequal between 0 and 5 dBm, readjust A4R68. Conversely, if they are unequal between 5 and 10 dBm, readjust A4R70.

5-12.2 ALC Loop Adjustments (Model 6642A, 26.5 to 40 GHz Band)

The ALC loop adjustments for the 6642A are divided into three groups: ALC Bandwidth, RF Slope, and Power Level.

a. ALC Loop Bandwidth Adjustments (26.5-40 GHz Band)

1. Set up the test equipment as shown in Figure 5-42 (oscilloscope connected to the directional coupler); turn the equipment on.
2. Remove the top cover from the sweep generator (sweeper). Refer to paragraph 7-3.1 for instructions, if necessary.
3. Adjust the function generator to

supply the sweeper with a 10 kHz, 0-300 mV square wave.

4. Press RESET on sweeper.
5. Press CW F1 and set for 30 GHz.
6. Press LEVEL and set for -5 dBm.
7. Place EXT ALC GAIN control to midrange.
8. Adjust the oscilloscope vertical and horizontal controls to display a square wave similar to that shown in Figure 5-43.
9. Alternately adjust A4R124 and A7R34 (Figure 5-38) for the best square-wave response. The square wave should resemble Figure 5-43.

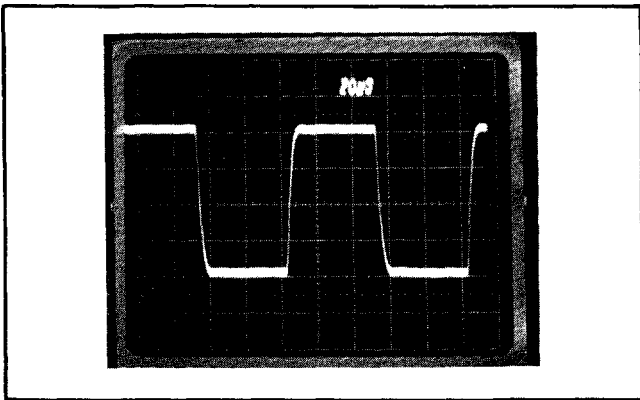

Figure 5-43. ALC Loop Square Wave

10. With the oscilloscope, verify the following signal parameters at 0 and -10 dBm power-level settings.
 - Overshoot: <20%
 - Rise Time: <7 μ s.
11. Verify the square-wave response at the upper and lower limits of the 10 dBm leveled-power range; see Table 5-7.

b. RF SLOPE Adjustment

1. Disconnect oscilloscope from the directional coupler and connect the power meter's R486A Thermistor

Mount in its place.

2. Press LEVEL and set for -5 dBm.
3. Press F1 and set for 40.000 GHz.
4. Record the power meter reading.
5. Disconnect the R486A Thermistor Mount from the power meter, and connect a K482A Thermistor Mount between the power meter and the 18-26.5 GHz RF OUTPUT connector on the sweeper.
6. Press F1 and set for 18.000 GHz.
7. Record the power meter reading.
8. Adjust A4R115 (Figure 5-38) for equal power at 18 and 26.5 GHz.

c. Power Level Adjustments

1. Press LEVEL and set for +3 dBm.
2. Adjust A4R66 for a power meter reading of +3.0 dBm.
3. Set LEVEL for -7.0 dBm.
4. Adjust A4R72 for a power meter reading of -7.0 dBm.
5. Repeat steps 2 thru 5 as necessary until the power levels are +3.0 dBm and -7.0 dBm respectively, ± 0.1 dB.
6. Disconnect the K482A Thermistor Mount from the power meter, and reconnect the R482A Thermistor Mount.
7. Press LEVEL and set for +1 dBm.
8. Press F1 and set for 26.500 GHz.
9. Verify that the power meter reads +1.0 dBm ± 0.1 dB.
10. Press LEVEL and set for -9.0 dBm.
11. Verify that the power meter reads -9.0 dBm ± 0.1 dB.

SECTION VI

PARTS LISTS

6-1 INTRODUCTION

This section provides parts lists for the multiband models of the WILTRON 6600A Programmable Sweep Generators. The parts lists are divided into three groups: major assembly parts, printed circuit board (PCB) parts, and options/accessories. Major assembly parts are illustrated in Figures 6-1 thru 6-9. PCB parts, including optional PCB's, are tabulated in Tables 6-1 thru 6-25. Options and accessories are listed in Table 6-26.

6-2 PARTS-ORDERING INFORMATION

Replaceable parts may be ordered either from the local WILTRON representative or directly from the factory.

WILTRON Company
825 East Middlefield Road
Mountain View, California 94043

Telephone: (415) 969-6500
TWX: 910-379-6578

When ordering, give complete information including the model and serial number of the instrument, the full part description, the WILTRON part number, and the quantity required.

6-3 ABBREVIATIONS

The following abbreviations appear in the "DESCRIPTION" column of the WILTRON parts lists:

CC - Carbon Composition
MF - Metal Film
WW - Wire-Wound

6-4 ORGANIZATION OF PARTS LISTINGS

The replaceable-parts lists are arranged under the following three categories:

Illustrated Major Assembly Parts Lists

<u>Fig.</u>	<u>Major Assembly</u>	<u>Page</u>
6-1	A0 Basic Frame Assy.	6-2
6-2	Top Assy.	6-4
6-3	A15 Front Panel Assy.	6-6
6-4	A16 Rear Panel Assy.	6-8
6-5	RF Deck Assy. - 6609A/6617A	6-10
6-6	RF Deck Assy. - 6621A/6621A-40/6629A/ 6629A-40/6637A/6637A-40/ 6638A/6647A/6648A	6-11
6-7	RF Deck Assy. - 6642A	6-12
6-8	RF Deck Assy. - 6653A/6659A	6-13
6-9	Oscillator Assy.	6-14

PCB Assembly Parts Lists

<u>Table</u>	<u>PCB/PCB Assembly No.</u>	<u>Page</u>
6-1	A1 GPIB Interface, Option 3 (660-D-8001)	6-16
6-2	A2 Ramp Generator (660-D-8002)	6-16
6-3	A3 Marker Generator (660-D-8003)	6-18
6-4	A4 ALC (660-D-8004)	6-20
6-5	A5 Frequency Instruction (660-D-8005)	6-22
6-6	A6 HET/YIG Driver, .01-2 GHz, 6609A (660-D-8007-4)	6-23
6-7	A6 HET/YIG Driver, 2-8 GHz, 6617A (660-D-8007-6)	6-25
6-8	A6 HET/YIG Driver, 2-8 GHz, 6621A/ 6637A/6638A/6647A/ 6648A (660-D-8007-3, -5, -99-91)	6-26
6-9	A6 YIG Driver, 2-8 GHz 6621A-40/6637A-40 (660-D-12868-3, -99-91)	6-28
6-10	A6 YIG Driver, 18-26.5 GHz, 6642A (660-D-8190-99-96)	6-29
6-11	A6 HET/YIG Driver, 2-8 GHz, 6653A/6659A (660-D-8007-7)	6-31
6-12	A6/A7/A8 YIG Driver, 8-12.4 GHz, 6621A/6629A/ 6637A/6638A/6647A/6648A (660-D-8009-4, -6, -7, -8, -99-90, -99-92)	6-32
6-13	A6/A7 YIG Driver, 8-12.4 GHz, 6621A-40/6629A-40/6637A-40 (660-D-8009-14, -17, -99-91, -99-93)	6-34
6-14	A6/A7/A8 YIG Driver, 12.4-18.6 GHz, 6629A-40/ 6637A-40 (660-D-8009-15, -16, -99-94)	6-35

<u>Table</u>	<u>PCB/PCB Assembly No.</u>	<u>Page</u>	<u>Table</u>	<u>PCB/PCB Assembly No.</u>	<u>Page</u>
6-15	A7/A8 YIG Driver, 12.4-18.6 (20) GHz 6629A/6637A/6638A/6647A/ 6648A (660-D-8008-4, -7, -99-90)	6-37	6-23	(660-D-8012) A13 Switching Power Supply (660-D-8013)	6-47 6-48
6-16	A7 YIG Driver 26.5-40 GHz, 6642A (660-D-8191-99-93)	6-38	6-24	A14 Motherboard (660-D-8014)	6-50
6-17	A7 YIG Driver, 8-12.4 GHz, 6653A/6659A (660-D-8009-9, -12)	6-39	6-25	A18 GPIB Connector (660-B-8018)	6-52
6-18	A8 YIG Driver, 12.4-18.6 GHz, 6653A/6659A (660-D-8009-10, -13)	6-41	<u>Options and Accessories Parts List</u>		
6-19	A9 YIG Driver, 18-26.5 GHz, 6653A/6659A (660-D-8009-11)	6-42	<u>Table</u>	<u>Name</u>	<u>Page</u>
6-20	A10 FM/Attenuator (660-D-8010)	6-43	6-26	Option 1, Rack Mount	6-53
6-21	A11 Front Panel (660-D-8011)	6-45	6-26	Option 2, Step Attenuator	6-53
6-22	A12 Microprocessor		6-26	Option 3, GPIB Interface	6-53
			6-26	Option 11, External Square- Wave Input, Standard (except 6642A)	6-53
			6-26	Option 13, Counted Markers	6-53
			6-26	Accessories	6-53

**INDEX
NO.**

NAME

PART NO.

1	A2 Ramp Generator PCB (Table 6-2)	660-D-8002
2	A3 Marker Generator PCB (Table 6-3)	660-D-8003
3	A4 Automatic Level Control (ALC) PCB (Table 6-4)	660-D-8004
4	A5 Frequency Instruction PCB (Table 6-5)	660-D-8005
5	A10 FM/Attenuator PCB (Table 6-20)	660-D-8010
6	A14 Motherboard PCB (Table 6-24)	660-D-8014
7	A15 Front Panel Assembly (Figure 6-3)	660-D-8015
8	Casting, Finished Front	660-D-8084
9	Bracket, Support, Front	660-B-8030
10	Clip, Mounting (heat sink & bracket for PCB and POWER switch support)	660-B-8031
11	Card Cage, Front	660-D-8069
12	Bracket, Support, Rear	660-B-8034
13	Casting, Finished Rear	660-D-8083
14	Cable Assembly (Regulator to Motherboard)	660-A-8033
15	Card Cage, Rear	660-D-8070
16	A13 Switching Power Supply PCB (Table 6-23)	660-D-8013
17	Bracket, PCB, Rear	660-B-8028
18	Bracket, PCB, Front	660-B-8027
19	A16 Rear Panel Assembly (Figure 6-4)	660-D-8016
20	Clip, Mounting (PCB)	660-B-8032
21	Plate, POWER Switch Mounting	560-A-7053
22	Extrusion, Corner Frame	660-B-8082
23	POWER Switch Extender Assembly	660-D-8025
24	Clip, Mounting, POWER Switch	560-B-7044
25	Plate, POWER Switch Support	660-A-8099
26	Guide, PCB	553-97
27	Guide, PCB	553-41
-	Heat Sink	553-65
28	Guide, PCB	660-A-8035
29	Card Cage, Top	660-B-8068

Figure 6-1. A0 Basic Frame Assembly (Sheet 1 of 2)

**INDEX
NO.**

NAME

PART NO.

30	Shield, Voltage Protection	660-B-8072
-	Angle Support, PCB	660-B-8029
-	Regulator, +15V, 7815	54-MC7815CP
-	Regulator, -15V, 7915	54-MC7915CP
-	Regulator, -15V, μ A79HGKC	54-145
-	Insulator, Mica	790-70
-	Clamp, Cable	720-3/16
-	Washer, Shoulder	790-52

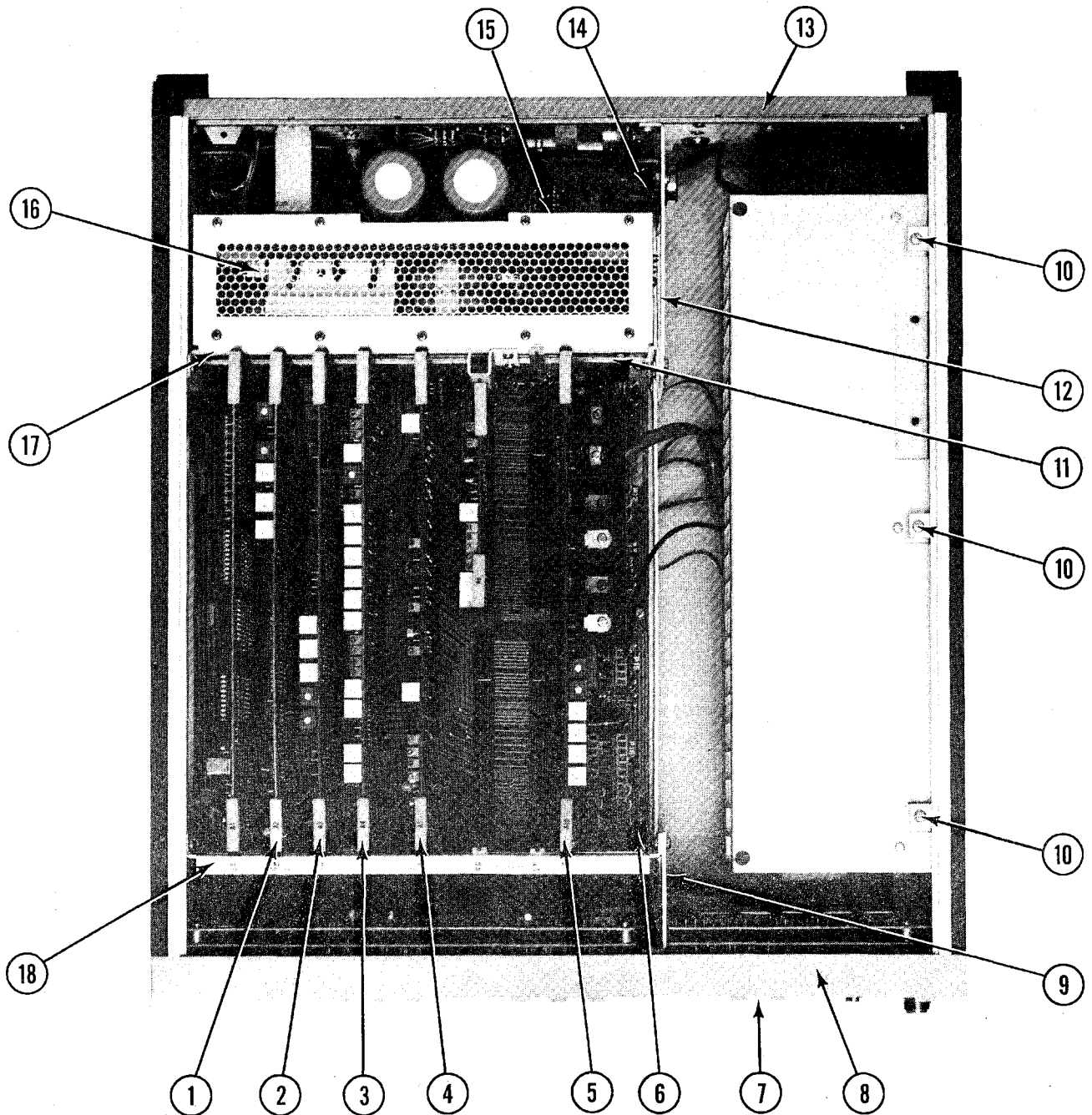

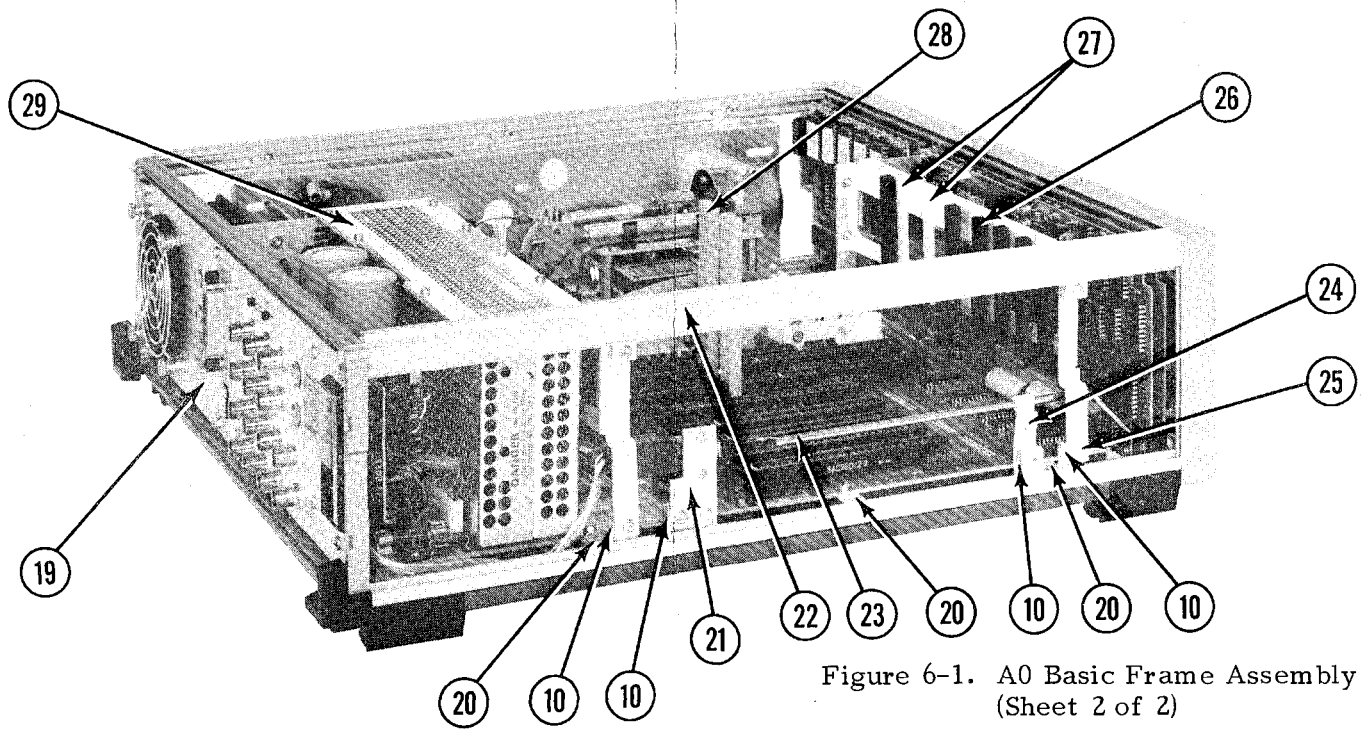
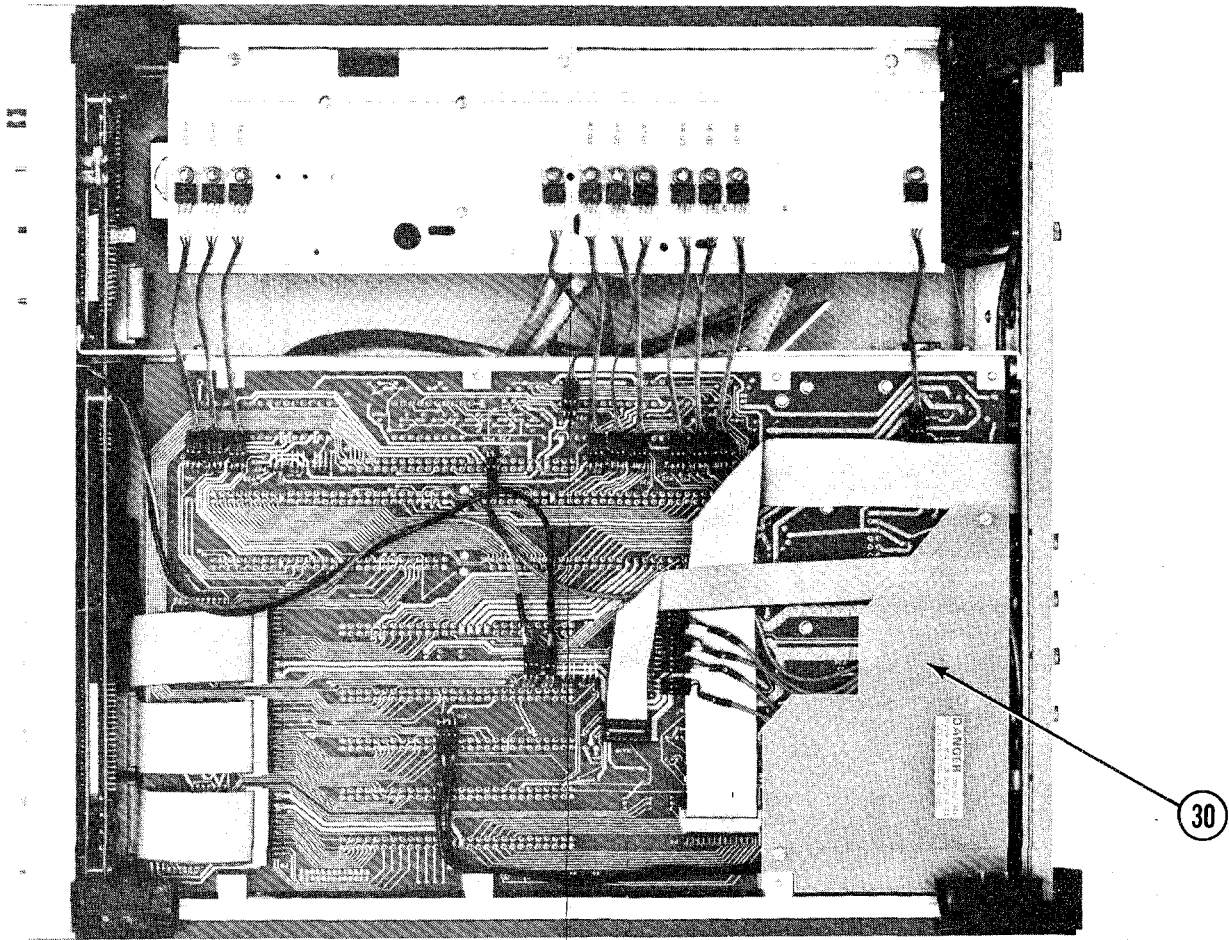
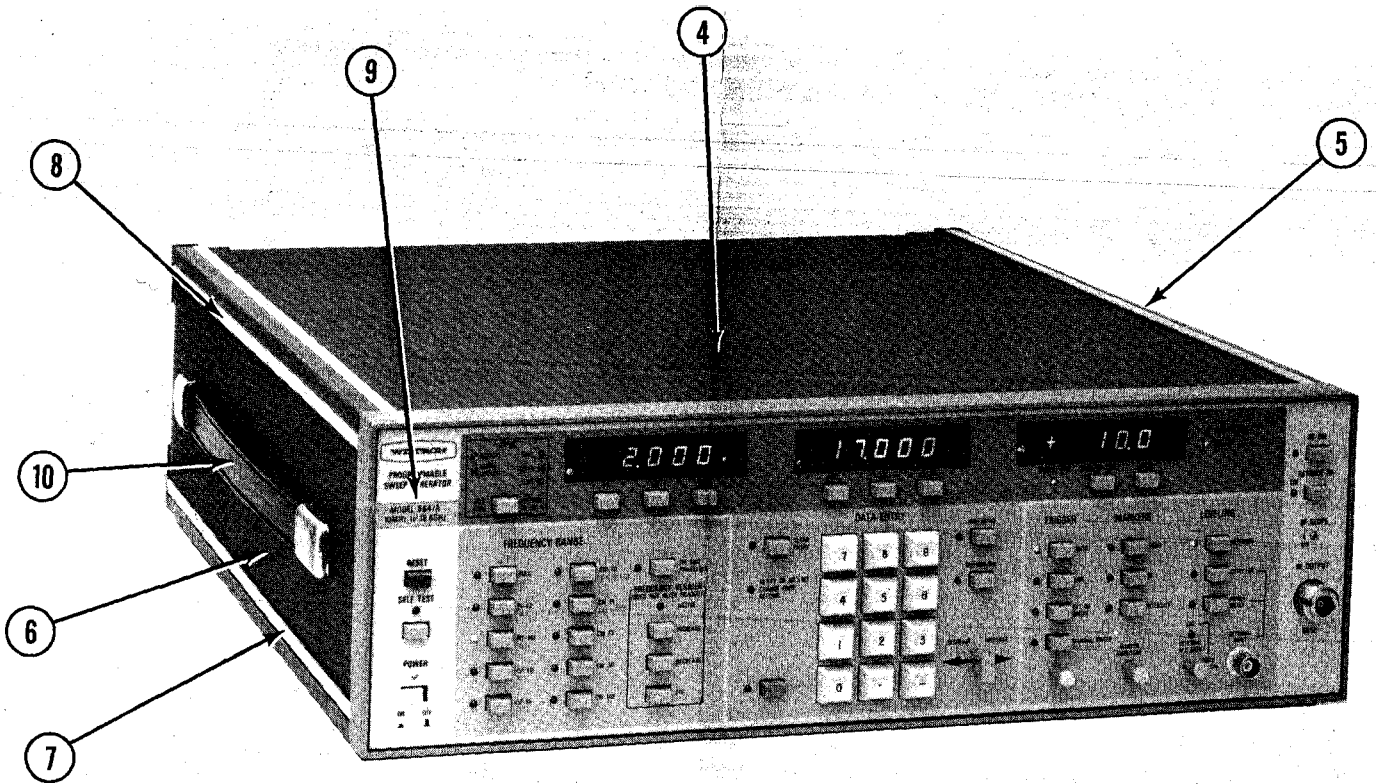

Figure 6-1. A0 Basic Frame Assembly
(Sheet 2 of 2)



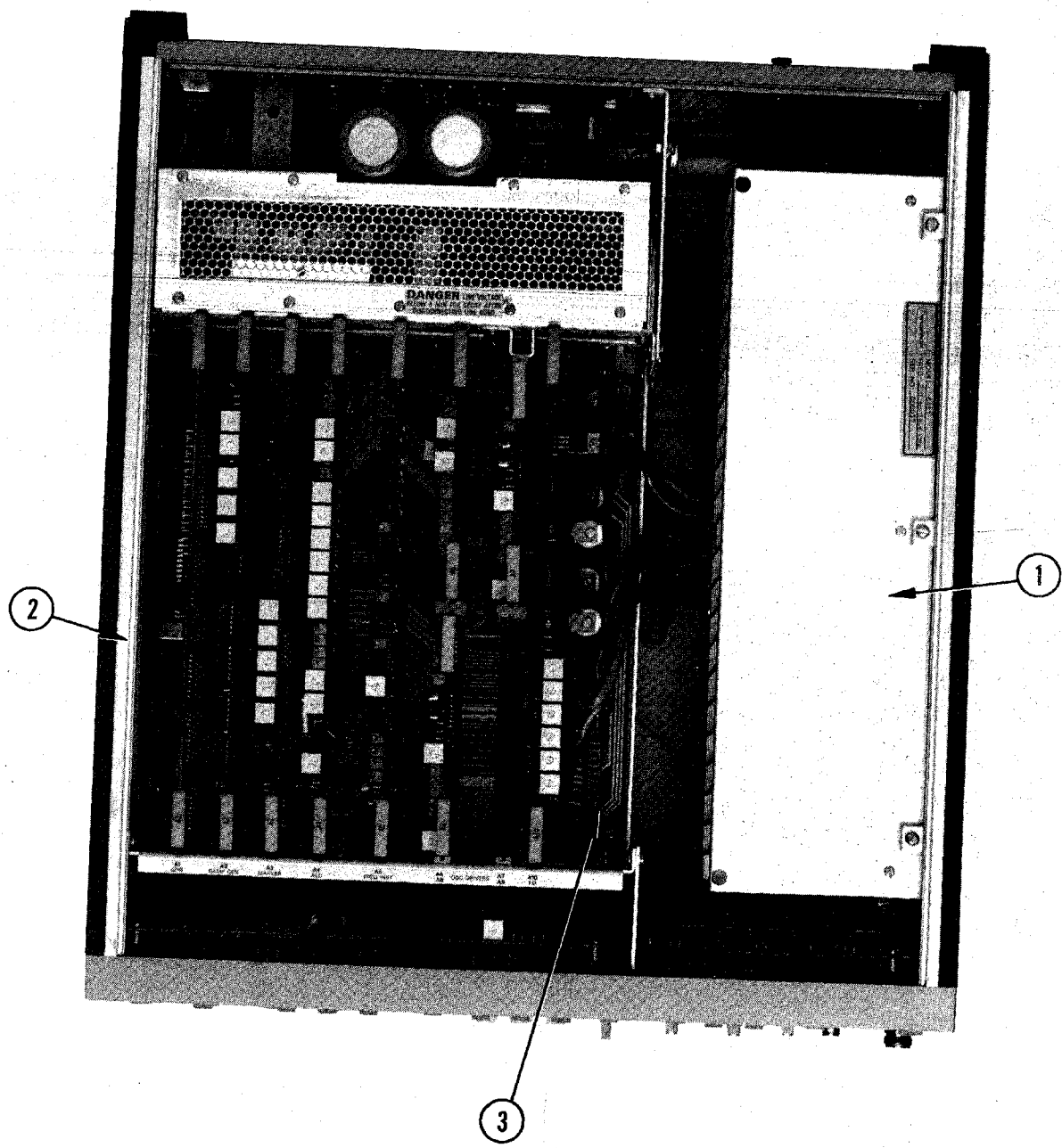

Figure 6-2. Top Assembly (Sheet 1 of 2)

Reference
Photo

INDEX NO.	NAME	PART NO.
1	RF Deck Assembly (Figure 6-5 thru 6-8)	
	a. 6609A	660-D-8050
	b. 6617A	660-D-8057-1
	c. 6621A	SPCL-D-11550
	d. 6621A-40	SPCL-D-13065
	e. 6629A	SPCL-D-11585
	f. 6629A-40	SPCL-D-13079
	g. 6637A	660-D-8053-1
	h. 6637A-40	660-D-12871-1
	i. 6638A	660-D-8058-1
	j. 6642A	SPCL-D-11620
	k. 6647A	660-D-8054-1
	l. 6648A	660-D-8055-1
	m. 6653A	660-D-12608-1
	n. 6659A	660-D-12609-1
2	Basic Frame Assembly (Figure 6-1)	660-D-8000
3	Connector Jumper Assembly	660-A-8144
4	Covers, Top and Bottom	660-D-8044
5	Cover, Right Side	660-D-8045
6	Cover, Left Side	660-D-8046
7	Trim Strip, Bottom	560-B-7036
8	Trim Strip, Top	560-B-7037
9	Model Number Nameplate	
	a. 6609A	660-B-8093-3
	b. 6617A	660-B-8093-7
	c. 6621A	SPCL-A-11554
	d. 6621A-40	SPCL-A-13076
	e. 6629A	SPCL-A-11589
	f. 6629A-40	SPCL-A-13083
	g. 6637A	660-B-8093-2
	h. 6637A-40	660-B-8093-11
	i. 6638A	660-B-8093-8
	j. 6642A	SPCL-A-11625
	k. 6647A	660-B-8093-1
	l. 6648A	660-B-8093-9
	m. 6653A	660-B-8093-12
	n. 6659A	660-B-8093-10
10	Handle Assembly	
	Strap	783-100
	Cap	783-11
	Bracket	783-12
-	Coupler Assembly (No RF OUTPUT Options)	
	a. 6609A	660-B-8125-1
	b. 6638A/6648A	660-B-8125-4
	c. All others	660-B-8125-2
-	Tilt Bail	2000-61F
-	Foot, Bottom	2000-61G
-	Foot, Rear	2000-61H
-	Fuse, Line (2A SB, 3AG)	631-16
-	Cord, Line	800-119
-	Rubber Pad	2000-61K

Figure 6-2. Top Assembly (Sheet 2 of 2)

INDEX NO.	NAME	PART NO.
1	Potentiometer Assembly, EXTERNAL ALC GAIN	660-A-8024
2	Cable Assembly (EXTERNAL INPUT to A14P37)	660-A-8023
3	A12 Microprocessor PCB (Table 6-22)	660-D-8012
4	A11 Front Panel PCB (Table 6-21)	660-D-8011
5	Switch Assembly, INCREASE/ DECREASE	660-B-8017
6	Subpanel	660-D-8042
7	Button, RESET	SPEC-C-8187-3
8	Button, Grey (40 ea.)	SPEC-C-8187-1
9	Button, SHIFT	SPEC-C-8187-4
10	Buttons, Keypad	
	a. "1"	660-A-8073-1
	b. "2"	660-A-8073-2
	c. "3"	660-A-8073-3
	d. "4"	660-A-8073-4
	e. "5"	660-A-8073-5
	f. "6"	660-A-8073-6
	g. "7"	660-A-8073-7
	h. "8"	660-A-8073-8
	i. "9"	660-A-8073-9
	j. "0"	660-A-8073-10
	k. "."	660-A-8073-11
	l. "-"	660-A-8073-12
-	Knob (MANUAL SWEEP and MARKER AMPLITUDE)	61084-A-5452
-	Insert	A710-56
-	Knob, Push to Check (EXTERNAL ALC GAIN)	660-A-8064
-	Insert	710-56
-	Front Panel (Plastic)	660-D-8043
-	Connector, BNC, Insulated (EXTERNAL INPUT)	510-31
-	Connector Housing, 2-pin	551-230
-	Female Pins	551-154
-	Connector, Insulated Displacement for RG 174	551-233
-	Knob Retainer	710-56
-	Cable, Coax	800-5

Figure 6-3. A15 Front Panel Assembly (Sheet 1 of 2)

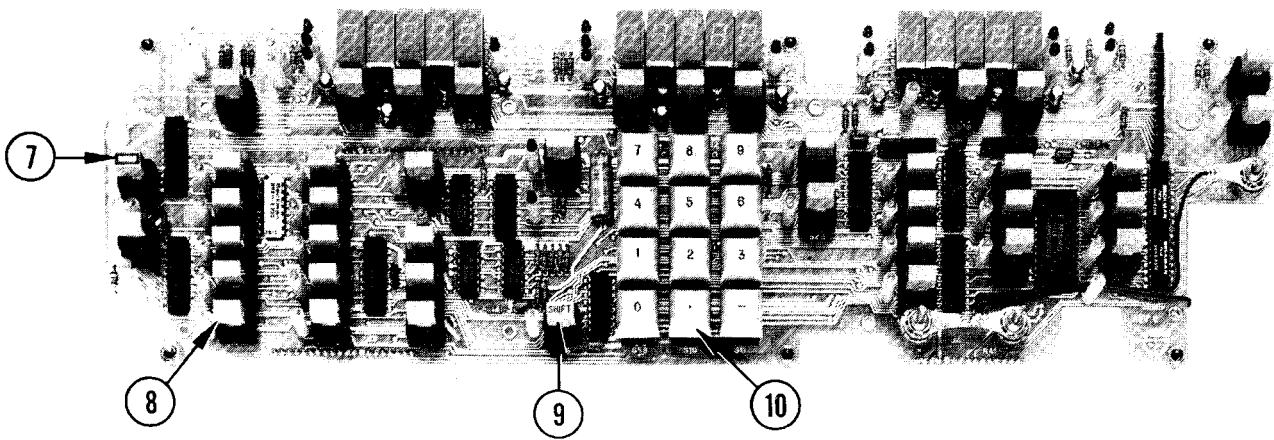
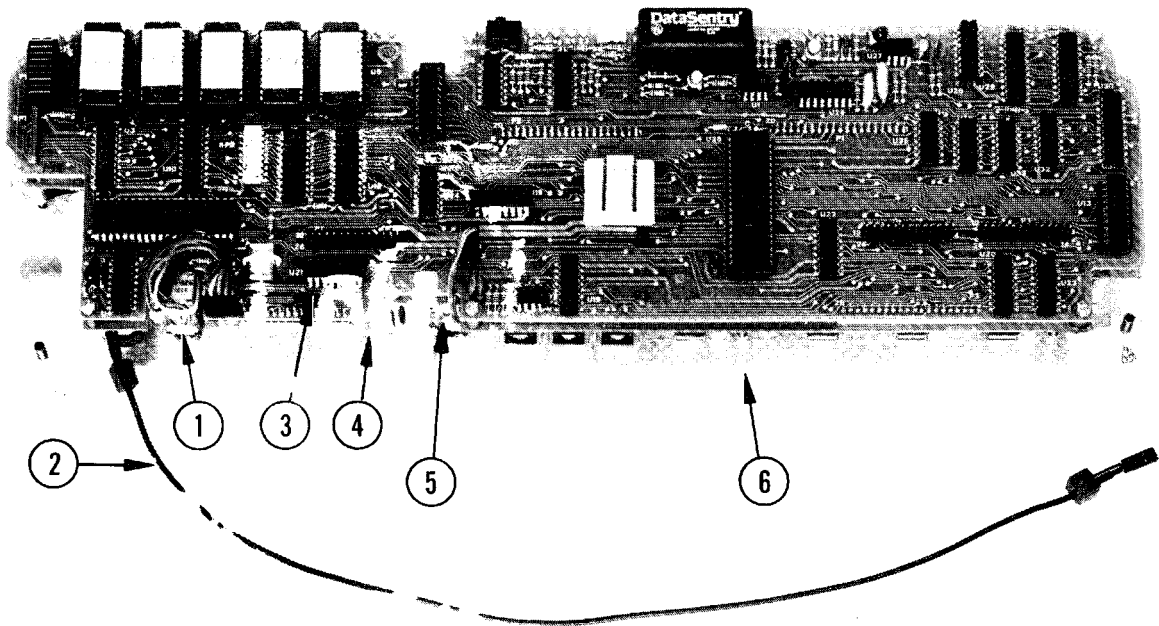

Figure 6-3. A15 Front Panel Assembly (Sheet 2 of 2)

**INDEX
NO.**

NAME

PART NO.

INDEX NO.	NAME	PART NO.
1	Shield, Fan	660-B-8142
2	Fan	650-4
3	Plug, Button, 5/8	790-42
4	Plug, Button, 1/4	790-146
5	Cover, GPIB (In place of cover, A18 GPIB Connector PCB (Table 6-25) is shown installed.)	560-A-7041
6	(Not shown) 25-pin Connector Housing #553-294; Receptacle, #553-89	660-A-12700
7	Switch, DPDT	430-49
8	Connector, BNC	510-5
9	Connector, BNC, Insulated	510-31
10	Plug, Button, 3/8	790-41
11	Transformer	320-58
12	Voltage Selector Module	551-142
	Female Pins, 14 ea.	551-155
13	Panel	660-D-8026
14	Connector Housing, 10-Pin	551-199
	Female Pins (Pins 1 & 3-10)	551-35
	Female Pin (Pin 2)	551-200
15	Switch, POWER	430-139
-	Connector Housing, 4-Pin	551-229
-	Connector Housing, 2-Pin	551-230
	Female Pins, 6 ea.	551-154
-	Connector Insulation (Displacement for RG 174)	551-233
-	Filter, Air	783-116
-	Finger Guard	790-142
-	Thumb Nut	790-143
-	Cable, Shielded Pair	800-28
-	Cable, Coax, RG174	800-5
-	Cable Assembly, Flat (between A14X16 and BNC connectors)	802-16A-23.4
-	Connector Housing, 3-Pin	551-202
	Receptacle	551-250
-	Capacitor, .0047 μ F, 3 kV	250-97

Figure 6-4. A16 Rear Panel Assembly (Sheet 1 of 2)

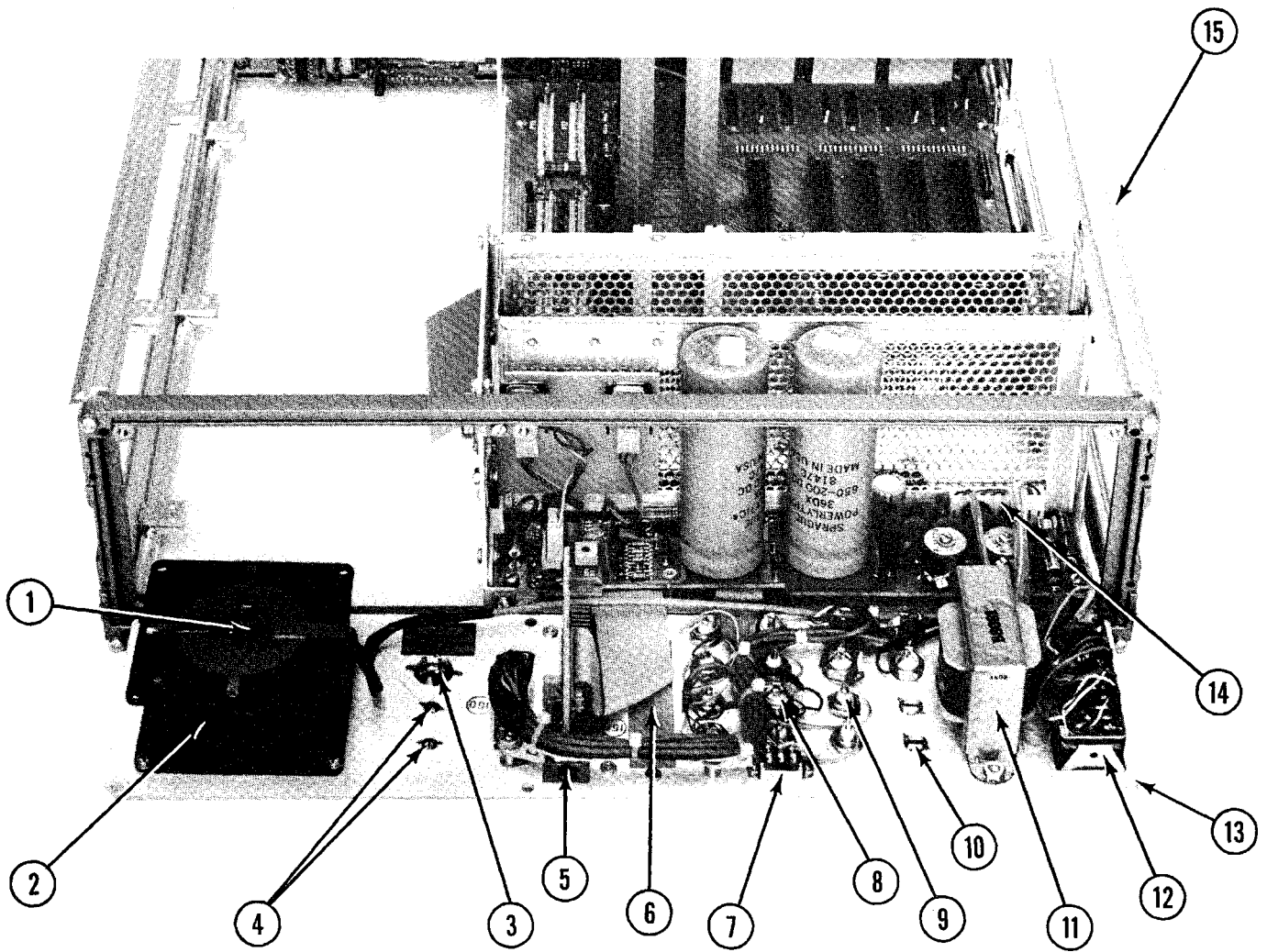

Figure 6-4. A16 Rear Panel Assembly (Sheet 2 of 2)

**INDEX
NO.**

NAME

PART NO.

1	YIG Oscillator Assembly (Figure 6-9) a. 4.6-6.6 GHz (6609A) b. 2-8 GHz (6617A)	660-C-8192 660-C-8087-2
2	Matched Modulator Assembly	660-B-9342
3	Filter	Figure 6-9
4	Cable Clip	721-17
5	Down Converter Assembly (6617A)	MEF-D-9157
6	DPDT Switch	660-B-8149
7	Transformer Assembly a. 6609A b. 6617A	320-65 320-66

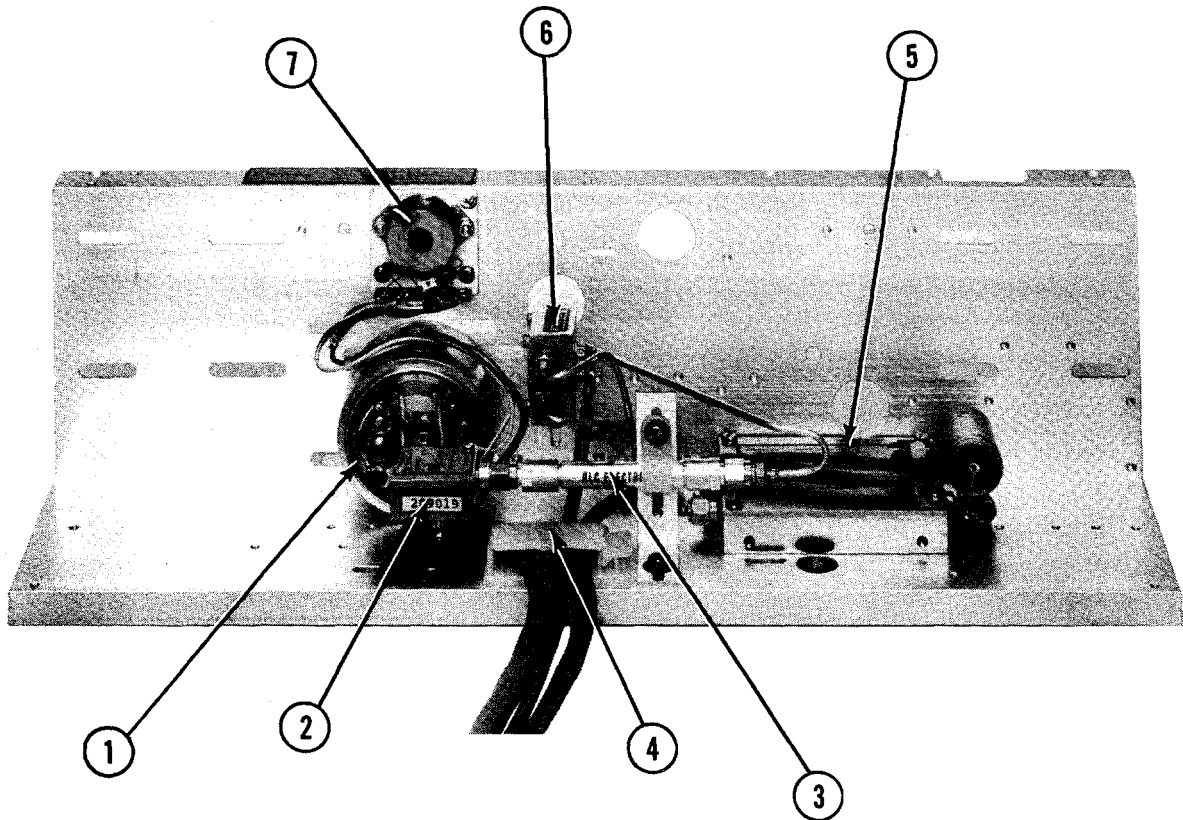

Figure 6-5. RF Deck Assembly - 6609A/6617A

**INDEX
NO.**

NAME

PART NO.

1	Oscillator Assembly, 12.4-18.6 (or 20) GHz a. 6629A/6637A/6647A b. 6629A-40/6637A-40 (1) Avantek Osc. & Amplica Amp. (2) Avantek Osc. & Litton Amp. (3) WJ Osc. & Amplica Amp. (4) WJ Osc. & Litton Amp.	Figure 6-9 660-C-8085-1 660-C-12872-2 660-C-12872-1 660-C-12872-4 660-C-12872-3
2	Isolator	Figure 6-9
3	Filter	Figure 6-9
4	Transformer, Compensation a. YIG Osc. P/N 1005-46 or 47 b. YIG Osc. P/N 1005-53 or 54 c. YIG Osc. P/N 1005-51, -52, -59	320-66 320-65 320-64
5	Oscillator Assembly, 2-8 GHz (Figure 6-9) a. 6621A/6637A/6638A/6647A/6648A b. 6621A-40/6637A-40 (1) Amplica Amp. (2) Litton Amp.	660-C-8087-1 660-C-12874-2 660-C-12874-1
6	Matched Modulator	660-B-9342
7	Cable Clip	721-17
8	Filter	Figure 6-9
9	Cable Coax, Filter to PIN Switch	660-A-8102-6
10	Down Converter Assembly	MEF-D-9157
11	Isolator	Figure 6-9
12	Oscillator Assembly, 8-12.4 GHz (Figure 6-9) a. 6621A/6629A/6637A/6647A (1) Avantek Osc. (2) WJ Osc. b. 6638A/6648A (1) Avantek Osc. (2) WJ Osc. c. 6621A-40/6637A-40 (1) Avantek Osc. & Amplica Amp. (2) Avantek Osc. & Litton Amp. (3) WJ Osc. & Amplica Amp. (4) WJ Osc. & Litton Amp.	660-C-8086-2 660-C-8086-3 660-C-8086-5 660-C-8086-4 660-C-12873-2 660-C-12873-1 660-C-12873-4 660-C-12873-3
13	Cable Assembly, Isolator to Filter	660-A-8102-6
14	Filter	Figure 6-9
15	PIN Switch Assembly	660-D-8821
-	Voltage Regulator, -5V	54-184
-	10 dB Pad	1010-28

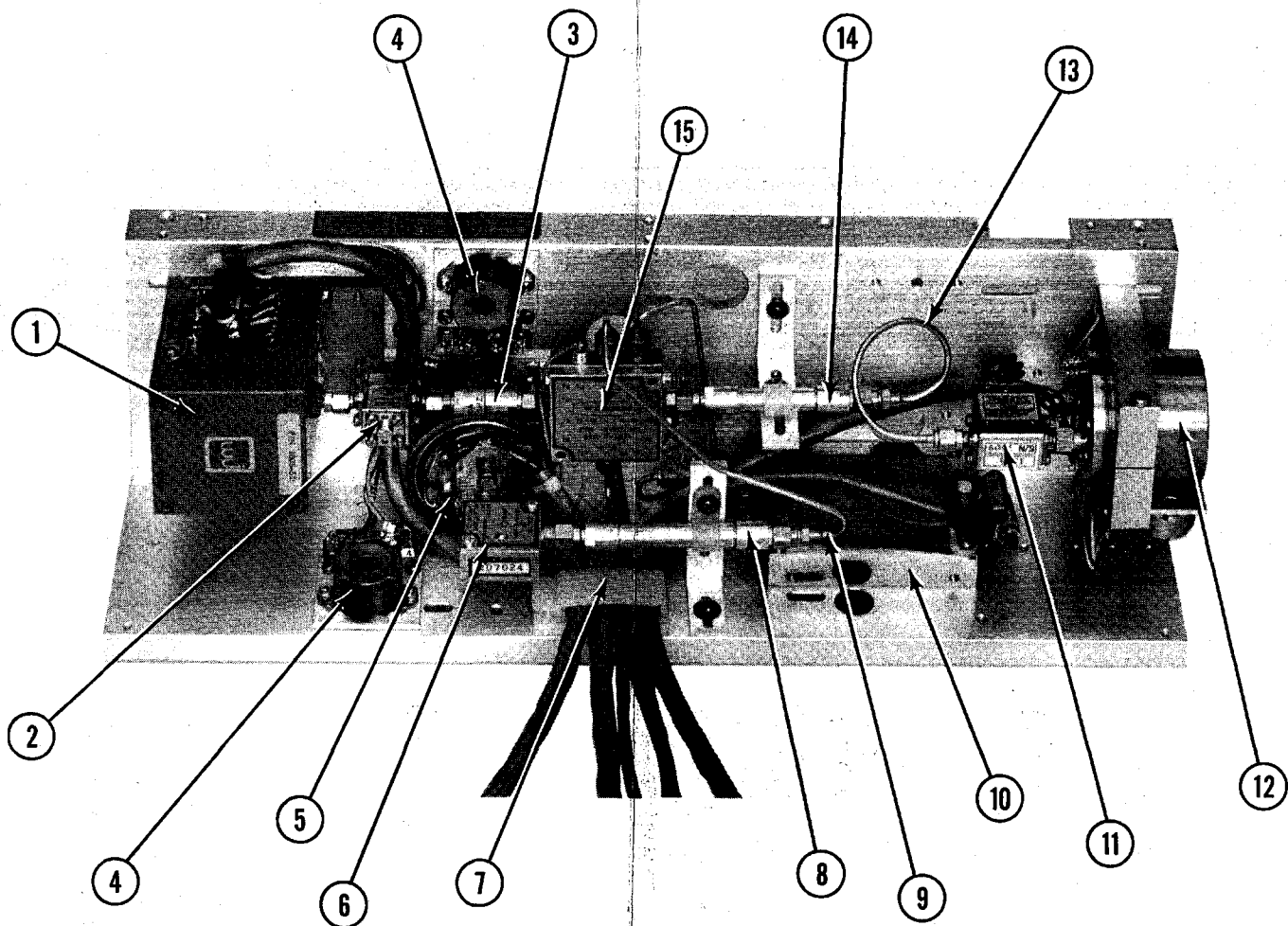

Figure 6-6. RF Deck Assembly - 6621A/
 6621A-40/6629A/6629A-40/
 6637A/6637A-40/6638A/6647A/
 6648A

**INDEX
NO.****NAME****PART NO.**

1	Oscillator Assembly, 18-26.5 GHz (Figure 6-9)	660-C-8175-2
2	Isolator	Figure 6-9
3	Down Converter Assembly (6659A)	MEF-D-9157
4	Cable Assembly, Down Converter to PIN Switch J1	CABL-A-9202-24
5	10 dB Pad	1010-28
6	PIN Switch Assembly	660-D-11745-2
7	Cable Assembly, 10 dB Pad to PIN Switch J6	CABL-A-9202-23
8	Oscillator Assembly, 12.4-18 GHz (Figure 6-9)	
	a. Avantek Oscillator	660-C-8085-2
	b. WJ Oscillator	660-C-8085-3
9	Filter	Figure 6-9
10	Cable Assembly, Filter to PIN Switch J2	CABL-A-9203-6
11	Cable Assembly	
	a. Avantek Oscillator to Filter	CABL-A-9201-22
	b. WJ Oscillator to Isolator	CABL-A-9204-5
12	Cable Clip	721-17
13	Matched Modulator Assembly	660-B-9342
14	Oscillator Assembly, 2-8 GHz (Figure 6-9)	660-C-8087-4
15	Transformer, Compensation	
	a. YIG Oscillator 1005-46 or -47	320-66
	b. YIG Oscillator 1005-53 or -54	320-65
	c. YIG Oscillator 1005-55, -59, or -61	320-64
16	Oscillator Assembly, 8-12.4 GHz (Figure 6-9)	
	a. Avantek Oscillator	660-C-8086-6
	b. WJ Oscillator	660-C-8086-7
17	Cable Assembly, Filter to PIN Switch J3	CABL-A-9202-22
-	Transistor, PNP, TIP 117	20-5
-	Voltage Regulator, -5V	54-184

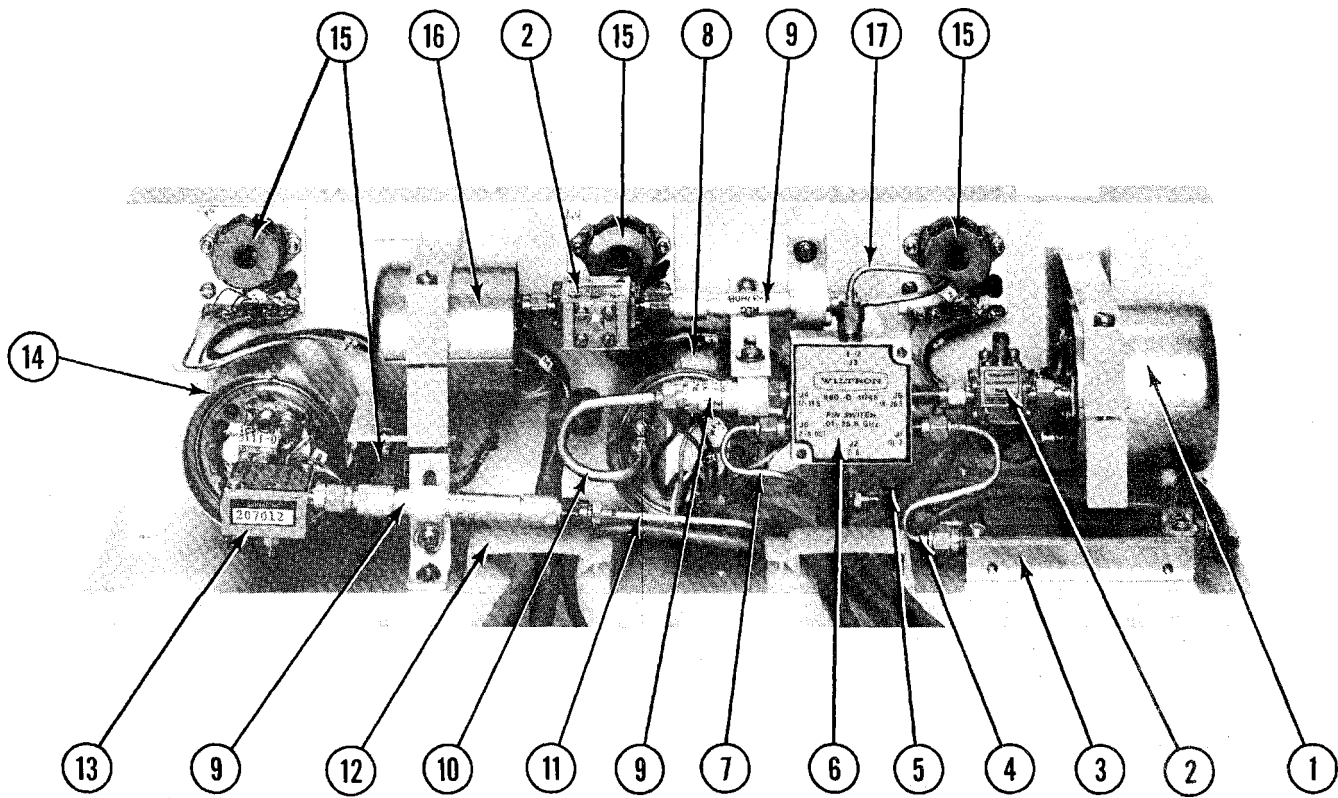
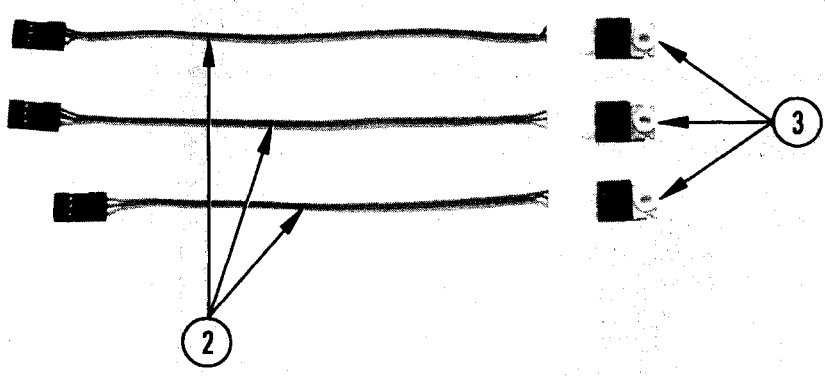
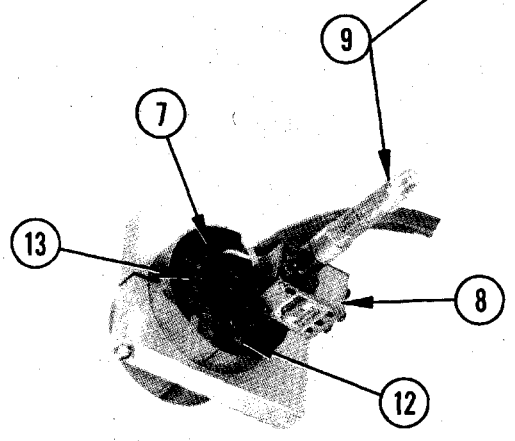
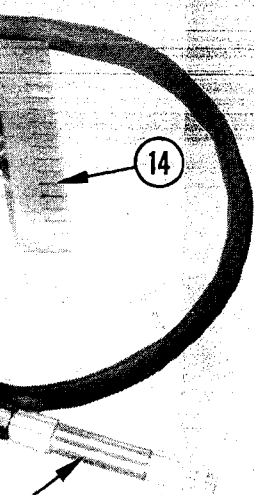
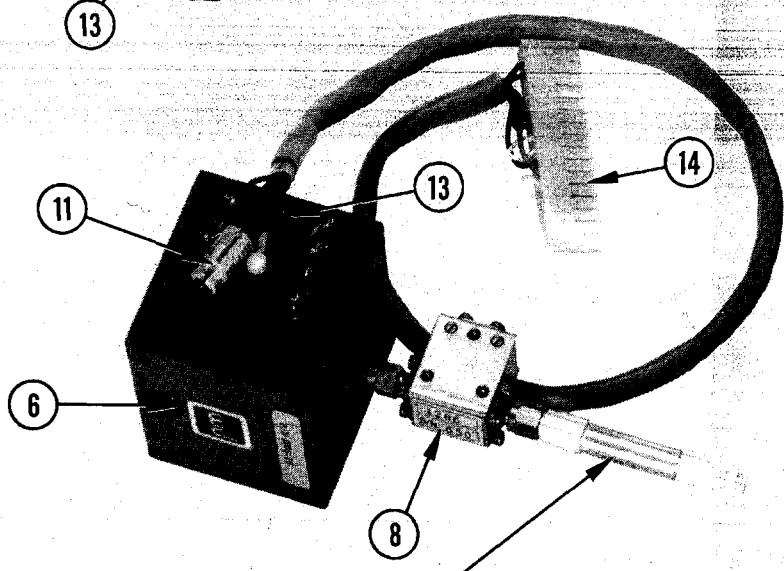
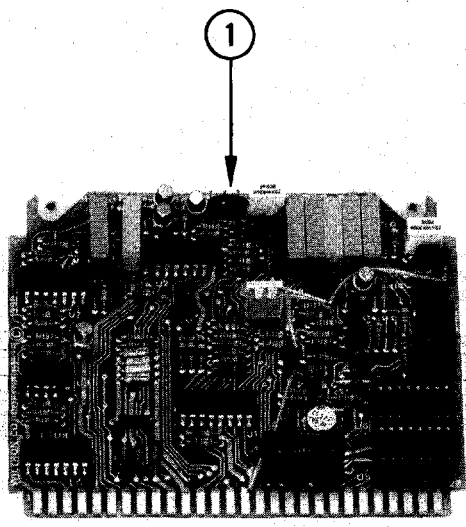
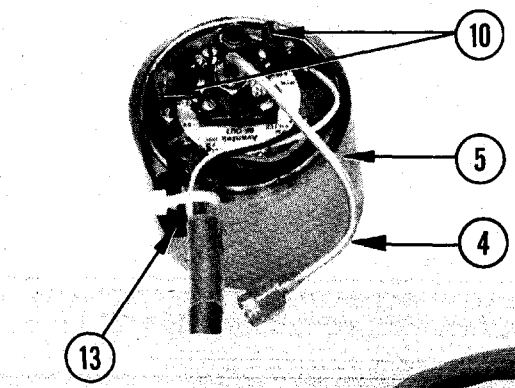

Figure 6-8. RF Deck Assembly - 6653A/6659A



**INDEX
NO.**

NAME

PART NO.

INDEX NO.	NAME	PART NO.
1	PCB Assembly, YIG Driver	
	a. 2-8 GHz (6609A, Table 6-6)	660-D-8007-4
	b. 2-8 GHz (6617A, Table 6-7)	660-D-8007-6
	c. 2-8 GHz (6621A, Table 6-8)	660-D-8007-99-91
	d. 2-8 GHz (6637A/6647A, Table 6-8)	660-D-8007-3
	e. 2-8 GHz (6621A-40, Table 6-9)	660-D-12868-99-91
	f. 2-8 GHz (6637A-40, Table 6-9)	660-D-12868-3
	g. 2-8 GHz (6638A/6648A, Table 6-8)	660-D-8007-5
	h. 2-8 GHz (6653A/6659A Table 6-11)	660-D-8007-7
	i. 8-12.4 GHz	
	(1) Avantek (6621A, Table 6-12)	660-D-8009-99-90
	(2) Avantek (6621A-40, Table 6-13)	660-D-8009-99-91
	(3) Avantek (6629A, Table 6-12)	660-D-8009-99-92
	(4) Avantek (6629A-40, Table 6-13)	660-D-8009-99-93
	(5) Avantek (6637A/6647A, Table 6-12)	660-D-8009-4
	(6) Avantek (6637A-40, Table 6-13)	660-D-8009-14
	(7) Avantek (6638A/6648A, Table 6-12)	660-D-8009-6
	(8) Avantek (6653A/6659A, Table 6-17)	660-D-8009-9
	(9) WJ (6637A/6647A, Table 6-12)	660-D-8009-7
	(10) WJ (6637A-40, Table 6-13)	660-D-8009-17
	(11) WJ (6638A/6648A, Table 6-12)	660-D-8009-8
	(12) WJ (6653A/6659A, Table 6-17)	660-D-8009-12
	j. 12.4-18.6 GHz	
	(1) Avantek (6629A-40, Table 6-14)	660-D-8009-99-94
	(2) Avantek (6637A-40, Table 6-14)	660-D-8009-16
	(3) Avantek (6653A/6659A, Table 6-18)	660-D-8009-10
	(4) WJ (6629A, Table 6-15)	660-D-8008-99-90
	(5) WJ (6637A/6647A, Table 6-15)	660-D-8008-4
	(6) WJ (6637A-40, Table 6-14)	660-D-8009-15
	(7) WJ (6653A/6659A, Table 6-18)	660-D-8009-13
	k. 12.4-20 GHz (6638A/6648A, Table 6-15)	660-D-8008-7
	l. 18.6-26.5 GHz (6653A/6659A, Table 6-19)	660-D-8009-11
	m. 18.6-26.5 GHz (6642A, Table 6-10)	660-D-8190-99-98
	n. 26.5-40 GHz (6642A, Table 6-16)	660-D-8191-99-93
2	Cable, Transistor (3 ea)	660-A-8100
3	Transistors Q1, Q2, Q3;	20-2N6044
	Q1 on 6609A/6617A; .01-18 GHz band	20-2N6041
	of 6637A/6637A-40/6647A/6653A and 6659A; and	
	8-12.4 GHz band of 6637A/6637A-40/6638A/6647A/6648A	
4	Cable, SMA Male-Male, RG085	660-A-8101-5

Figure 6-9. Oscillator Assembly (Sheet 1 of 2)

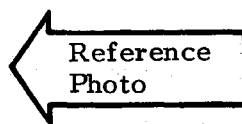

INDEX NO.	NAME	PART NO.
—	YIG Oscillator, 4.6-6.6 GHz (6609A)	
	a. Avantek	1005-45
	b. WILTRON	1005-C-11236
5	YIG Oscillator, 2-8 GHz (All except 6609A/6642A)	1005-46 or -47
6	YIG Oscillator, WJ	
	a. 8-12.4 GHz (6637A/6637A-40/6638A/6647A/6648A/ 6653A/6659A)	1005-54
	b. 12.4-18.6 GHz (6629A/6637A/6637A-40/6647A/ 6653A/6659A)	1005-51
	c. 12.4-18.0 GHz (6653A/6659A)	1005-55
	d. 12.4-20 GHz (6638A/6648A)	1005-52
	e. 13.25-20 GHz (6642A)	1005-40
7	YIG Oscillator, Avantek	
	a. 8-12.4 GHz (6621A/6621A-40/6629A/6629A-40/ 6637A/6637A-40/6638A/6647A/6648A)	1005-53
	b. 12.4-18.6 GHz (6629A-40/6637A-40/6653A/6659A)	1005-59
	c. 18-26.5 GHz (6642A)	1005-61
8	Isolator	
	a. 4-8 GHz (6621A/6621A-40/6629A/6629A-40/6637A/ 6637A-40/6638A/6647A/6648A/6653A/6659A)	1000-29
	b. 7-12.4 GHz (6621A/6621A-40/6629A/6629A-40/6637A/ 6637A-40/6638A/6647A/6648A/6653A/6659A)	1000-21
	c. 12.4-18.6 GHz (6629A/6629A-40/6637A/6637A-40/ 6647A/6653A/6659A)	1000-20
	d. 12.4-20 GHz (6638A/6648A)	1000-35
9	Low-Pass Filter	
	a. 2-8 GHz (All except 6609A/6642A)	1030-26
	b. 8-12.4 GHz (6621A/6621A-40/6629A/6629A-40/6637A/ 6637A-40/6638A/6647A/6648A/6653A/6659A)	1030-29
	c. 2-18.7 GHz (6629A/6629A-40/6637A/6637A-40/6638A/ 6647A/6648A/6653A/6659A)	1030-31
	d. 12.4-20 GHz (6638A/6648A)	1030-32
10	Capacitor, Tantalum, 10 μ F, 25V	250-42
11	Capacitor	
	a. 8-12.4 GHz Oscillator on 6653A/6659A: 15 μ F	250-25
	b. 8-12.4 GHz Oscillator on all others: 10 μ F	250-42A
	c. 12.4-18 GHz Oscillator on 6653A/6659A: 10 μ F	250-42
	d. 12.4-18 GHz Oscillator on all others: 100 μ F	250-50
12	Capacitor, Tantalum, 10 μ F	250-42
13	Core, Torroid	640-5
14	Connector Housing, 16-pin Female Pin	551-247 551-35
—	Resistor (R1) MF, 1/4W, 1%, 11 Ω	110-11-1
—	Cover (for Item 6 oscillator)	660-B-8160

Figure 6-9. Oscillator Assembly (Sheet 2 of 2)

Table 6-1. A1 GPIB Interface, Option 3 (660-D-8001)

<u>CAPACITORS</u>			<u>MISCELLANEOUS</u>		
REF. DES.	DESCRIPTION	WILTRON PART NO.	REF. DES.	DESCRIPTION	WILTRON PART NO.
C1	Tantalum, 2.2 μ F, 20V	250-40A	U6	74LS155, Dual 1-of-4 Decoder	54-101
C2	Tantalum, 2.2 μ F, 20V	250-40A	U7	74LS138, 1-of-8 Decoder	54-74LS138
C3	Tantalum, 10 μ F, 25V	250-42	U8	74LS373, Octal Latch	54-103
C4	Monolithic, .1 μ F, 50V	230-37	U9	Not Used	
C5	Monolithic, .1 μ F, 50V	230-37	U10	74LS04, Hex Inverter	54-74LS04
C6	Monolithic, .1 μ F, 50V	230-37	U11	74LS01, Quad Open Collector NAND	54-74LS01
C7	Monolithic, .1 μ F, 50V	230-37	U12	8085A, CPU	54-93
C8	Monolithic, .1 μ F, 50V	230-37	U13	74LS123 one shot	54-116
C9	Monolithic, .1 μ F, 50V	230-37	U14	7474, Dual D Flip-Flop	54-7474
			U15	74LS244, Non-inverting Octal Tri-State Driver	54-143
			U16	74LS244, Non-inverting Octal Tri-State Driver	54-143
			U17	8291 GPIB Listener/Talker	54-124
			U18	MC3447 Motorola GPIB Transreceiver, ceramic pkg., Cs. 623	54-142
			U19	MC3447 Motorola GPIB Transreceiver, ceramic pkg., Cs. 623	54-142
			U20	74LS74, Dual D Flip-Flop	54-44
			U21	74LS74, Dual D Flip-Flop	54-44
			U22	74LS374, Octal Latch	54-41
			U23	74LS112, Dual J-K Flip-Flop	54-74LS112
			U24	74LS374, Octal Latch	54-41
			U25	74LS00, Quad NAND	54-74LS00
			---	Socket, Dip, 18-Pin; U9	551-148
			---	Socket, Dip, 40-Pin; U1, 12, 17	553-66
			---	Socket, Dip, 24-Pin; U4, 5	553-67
			---	Plug, Dip, 18-Pin; U9	551-236

<u>CAPACITORS</u>			<u>INTEGRATED CIRCUITS, SOCKETS, AND PLUGS</u>		
REF. DES.	DESCRIPTION	WILTRON PART NO.	REF. DES.	DESCRIPTION	WILTRON PART NO.
R1	MF, 1/4W, 1%, 5.11k	110-5.11k-1	U1	8255A, Programmable Interface	54-155
R2	MF, 1/4W, 1%, 10k	110-10k-1	U2	PD211ALC-4 256 x 4 Static RAM	54-11
R3	MF, 1/4W, 1%, 10k	110-10k-1	U3	PD211ALC-4 256 x 4 Static RAM	54-11
R4	MF, 1/4W, 1%, 10k	110-10k-1	U5	2716 2k x 8 EPROM	Contact WILTRON Customer Service
R5	MF, 1/4W, 1%, 10k	110-10k-1			
R6	MF, 1/4W, 1%, 40.2k	110-40.2k-1			
R7	MF, 1/4W, 1%, 487 Ω	110-487-1			
R8	MF, 1/4W, 1%, 40.2k	110-40.2k-1			
R9	MF, 1/4W, 1%, 10k	110-10k-1			
RP1	Resistor Network, 10k, 8-Pin, 7-Resistor	123-6			
RP2	Resistor Network, 10k, 8-Pin, 7-Resistor	123-6			

Table 6-2. A2 Ramp Generator (660-D-8002)

<u>CAPACITORS</u>			<u>MISCELLANEOUS</u>		
REF. DES.	DESCRIPTION	WILTRON PART NO.	REF. DES.	DESCRIPTION	WILTRON PART NO.
C1	Tantalum, 6V, 68 μ F	250-58	C12	Monolithic, 50V, .01 μ F	250-77
C2	Monolithic, 50V, .1 μ F	230-37	C13	Monolithic, 50V, .1 μ F	230-37
C3	Monolithic, 50V, .1 μ F	230-37	C14	Monolithic, 50V, .1 μ F	230-37
C4	Monolithic, 50V, .1 μ F	230-37	C15	Monolithic, 50V, .1 μ F	230-37
C5	Monolithic, 50V, .1 μ F	230-37	C16	Monolithic, 50V, .1 μ F	230-37
C6	Monolithic, 50V, .1 μ F	230-37	C17	Monolithic, 50V, .1 μ F	230-37
C7	Monolithic, 50V, .1 μ F	230-37	C18	Monolithic, 50V, .1 μ F	230-37
C8	Monolithic, 50V, .1 μ F	230-37	C19	Monolithic, 50V, .1 μ F	230-37
C9	Monolithic, 50V, .1 μ F	230-37	C20	Monolithic, 50V, .1 μ F	230-37
C10	Mica, 250V, 270 pF	223-270	C21	Monolithic, 50V, .1 μ F	230-37
C11	Monolithic, 50V, .01 μ F	250-77	C22	Monolithic, 50V, .1 μ F	230-37
			C23	Mylar, 250V, 1 μ F	210-36
			C24	Tantalum, 25V, 10 μ F	250-42
			C25	Tantalum, 25V, 10 μ F	250-42
			C26	Monolithic, 50V, .1 μ F	230-37
			C27	Mylar, 250V, .47 μ F	210-28

DIODES

REF. DES.	DESCRIPTION	WILTRON PART NO.
CR1	Silicon, 1N4446	10-1N4446
CR2	Reference, 1N823, 6.2V, 0.4W	10-1N823
CR3	Silicon, 1N4446	10-1N4446
CR4	Zener, 1N751A, 5.1V, 0.4W	10-1N751A
CR5	Silicon, 1N4446	10-1N4446
CR6	Silicon, 1N4446	10-1N4446
CR7	Silicon, 1N4446	10-1N4446
CR8	Silicon, 1N4446	10-1N4446
CR9	Zener, 1N751A, 5.1V, 0.4W	10-1N751A
CR10	Hot-carrier, MBD-501	10-4
CR11	Zener, 1N758A, 10V, 0.4W	10-1N758A
CR12	Silicon, 1N4446	10-1N4446
CR13	Zener, 1N751A, 5.1V, 0.4W	10-1N751A
CR14	Zener, 1N746A, 3.3V, 0.4W	10-1N746A
CR15	Zener, 1N751A, 5.1V, 0.4W	10-1N751A
CR16	Silicon, 1N4446	10-1N4446

TRANSISTORS

REF. DES.	DESCRIPTION	WILTRON PART NO.
Q1	2N3694, PNP, 0.2W	20-2N3694
Q2	2N4249, NPN, 0.4W	20-2N4249
Q3	2N3694, PNP, 0.2W	20-2N3694
Q4	2N3694, PNP, 0.2W	20-2N3694
Q5	2N3694, PNP, 0.2W	20-2N3694
Q6	2N4249, NPN, 0.4W	20-2N4249
Q7	2N3694, PNP, 0.2W	20-2N3694
Q8	J112, JFET	20-17
Q9	J112, JFET	20-17
Q10	2N3694, PNP, 0.2W	20-2N3694
Q11	2N4249, NPN, 0.4W	20-2N4249
Q12	2N3694, PNP, 0.2W	20-2N3694
Q13	2N4249, NPN, 0.4W	20-2N4249

RESISTORS

REF. DES.	DESCRIPTION	WILTRON PART NO.
R1	MF, 1/4W, 1%, 1.15 kΩ	110-1.15k-1
R2	MF, 1/4W, 1%, 17.4 kΩ	110-17.4k-1
R3	MF, 1/4W, 1%, 10 kΩ	110-10k-1
R4	MF, 1/4W, 1%, 9.76 kΩ	110-9.76k-1
R5	MF, 1/4W, 1%, 56.2Ω	110-56.2-1
R6	Variable, 1/2W, 10%, 200 kΩ	156-200k
R7	MF, 1/4W, 1%, 1 MΩ	110-1M-1A
R8	MF, 1/4W, 1%, 4.99 kΩ	110-4.99k-1
R9	MF, 1/4W, 1%, 2.74 kΩ	110-2.74k-1
R10	Variable, 1/2W, 10%, 10 kΩ	156-10k
R11	MF, 1/4W, 1%, 10.2 kΩ	110-10.2k-1
R12	MF, 1/4W, 1%, 10 kΩ	110-10k-1
R13	MF, 1/4W, 1%, 1.07 kΩ	110-1.07k-1
R14	MF, 1/4W, 1%, 19.6 kΩ	110-19.6k-1
R15	MF, 1/4W, 1%, 10 kΩ	110-10k-1
R16	MF, 1/4W, 1%, 392 kΩ	110-392k-1
R17	Variable, 1/2W, 10%, 500 kΩ	156-500k
R18	MF, 1/4W, 1%, 3.48 kΩ	110-3.48k-1
R19	MF, 1/4W, 1%, 10 kΩ	110-10k-1
R20	MF, 1/4W, 1%, 100Ω	110-100-1
R21	MF, 1/4W, 1%, 2.43 kΩ	110-2.43k-1
R22	MF, 1/4W, 1%, 10 kΩ	110-10k-1
R23	MF, 1/4W, 1%, 10 kΩ	110-10k-1
R24	MF, 1/4W, 1%, 10 kΩ	110-10k-1
R25	MF, 1/4W, 1%, 10 kΩ	110-10k-1

R26	MF, 1/4W, 1%, 20 kΩ	110-20k-1
R27	MF, 1/4W, 1%, 511Ω	110-511-1
R28	MF, 1/4W, 1%, 10 kΩ	110-10k-1
R29	MF, 1/4W, 1%, 10 kΩ	110-10k-1
R30	MF, 1/4W, 1%, 1.1 kΩ	110-1.1k-1
R31	Variable, 1/2W, 10%, 2 kΩ	156-2k
R32	MF, 1/4W, 1%, 9.53 kΩ	110-9.53k-1
R33	MF, 1/4W, 1%, 20 kΩ	110-20k-1
R34	MF, 1/4W, 1%, 49.9 kΩ	110-49.9k-1
R35	MF, 1/4W, 1%, 100Ω	110-100-1
R36	MF, 1/4W, 1%, 14.7 kΩ	110-14.7k-1
R37	MF, 1/4W, 1%, 10 kΩ	110-10k-1
R38	MF, 1/4W, 1%, 14.7 kΩ	110-14.7k-1
R39	Variable, 1/2W, 10%, 1 kΩ	156-1k
R40	MF, 1/4W, 1%, 14.7 kΩ	110-14.7k-1
R41	CC, 1/4W, 5%, 2.2 MΩ	101-2.2M-5
R42	MF, 1/4W, 1%, 49.9 kΩ	110-49.9k-1
R43	MF, 1/4W, 1%, 14.7 kΩ	110-14.7k-1
R44	MF, 1/4W, 1%, 20 kΩ	110-20k-1
R45	MF, 1/4W, 1%, 10 kΩ	110-10k-1
R46	MF, 1/4W, 1%, 10 kΩ	110-10k-1
R47	MF, 1/4W, 1%, 1.21 kΩ	110-1.21k-1
R48	MF, 1/4W, 1%, 20 kΩ	110-20k-1
R49	MF, 1/4W, 1%, 20 kΩ	110-20k-1
R50	MF, 1/4W, 1%, 140 kΩ	110-140k-1
R51	MF, 1/4W, 1%, 10 kΩ	110-10k-1
R52	MF, 1/4W, 1%, 511Ω	110-511-1
R53	MF, 1/4W, 1%, 10 kΩ	110-10k-1
R54	MF, 1/4W, 1%, 10 kΩ	110-10k-1
R55	MF, 1/4W, 1%, 10 kΩ	110-10k-1
R56	MF, 1/4W, 1%, 10 kΩ	110-10k-1
R57	MF, 1/4W, 1%, 10 kΩ	110-10k-1
R58	MF, 1/4W, 1%, 10 kΩ	110-10k-1
R59	MF, 1/4W, 1%, 34 kΩ	110-34k-1
R60	MF, 1/4W, 1%, 10 kΩ	110-10k-1
R61	MF, 1/4W, 1%, 3.48 kΩ	110-3.48k-1
R62	MF, 1/4W, 1%, 10 kΩ	110-10k-1
R63	MF, 1/4W, 1%, 10 kΩ	110-10k-1
R64	MF, 1/4W, 1%, 20 kΩ	110-20k-1
R65	MF, 1/4W, 1%, 10 kΩ	110-10k-1
R66	MF, 1/4W, 1%, 140 kΩ	110-140k-1
R67	MF, 1/4W, 1%, 10 kΩ	110-10k-1
R68	MF, 1/4W, 1%, 10 kΩ	110-10k-1
R69	MF, 1/4W, 1%, 1 kΩ	110-1k-1
R70	MF, 1/4W, 1%, 10 kΩ	110-10k-1
R71	MF, 1/4W, 1%, 3.48 kΩ	110-3.48k-1
R72	MF, 1/4W, 1%, 10 kΩ	110-10k-1
R73	MF, 1/4W, 1%, 10 kΩ	110-10k-1
R74	MF, 1/4W, 1%, 10 kΩ	110-10k-1
R75	CC, 1/4W, 5%, 1.2 MΩ	101-1.2M-5
R76	Variable, 1/2W, 10%, 1 MΩ	156-1M
R77	MF, 1/4W, 1%, 1 MΩ	110-1M-1A
R78	MF, 1/4W, 1%, 10 kΩ	110-10k-1
R79	MF, 1/4W, 1%, 10 kΩ	110-10k-1

INTEGRATED CIRCUITS

REF. DES.	DESCRIPTION	WILTRON PART NO.
U1	Dual D Flip-Flop, 74LS74	54-44
U2	Quad AND, 74LS08	54-74LS08
U3	Timer, NE-555	54-555
U4	Counter, 74LS161	54-60
U5	Hex Inverter, 74LS04	54-74LS04
U6	Decoder, 74LS138	54-74LS138
U7	Octal Latch, 74LS374	54-41
U8	2-1 Multiplexer, 74LS157	54-59
U9	4-Bit Counter, 74LS191	54-120
U10	Quad Inverter, 74LS05	54-105

U11	Dual D Flip-Flop, 74LS74	54-44	U26	Quad NAND, 74LS01	54-74LS01
U12	2-1 Multiplexer, 74LS157	54-59	U27	Quad NOR, 74LS02	54-57
U13	4-Bit Counter, 74LS191	54-120	U28	Dual Switch, DG200	50-DG200BA
U14	Octal Latch, 74LS374	54-41			
U15	8-Bit Latch/DAC, AD7524	54-129			
U16	Dual D Flip-Flop, 74LS74	54-44			
U17	Quad NAND Gate, 74LS00	54-74LS00			
U18	Dual Op-Amp, TL072	54-53			
U19	Data Selector, 74LS151	54-119			
U20	Dual Op-Amp, TL072	54-53			
U21	Quad Switch, DG201	54-24			
U22	Dual D Flip-Flop, 74LS74	54-44			
U23	4-Input NAND, 74LS20	54-74LS20			
U24	Dual D Flip-Flop, 74LS74	54-44			
U25	QUAD Comparator, LM339	54-45			

MISCELLANEOUS

REF. DES.	DESCRIPTION	WILTRON PART NO.
K1	Relay	690-28
S1	Slide Switch	420-14
TP1		
thru		
TP7	Test Points	706-44
---	Ejector, P.C. Board	553-96

Table 6-3. A3 Marker Generator (660-D-8003)

CAPACITORS		
REF. DES.	DESCRIPTION	WILTRON PART NO.
C1	Tantalum, 68 μ F, 6V	250-58
C2	Monolithic, .1 μ F, 50V	230-37
C3	Monolithic, .1 μ F, 50V	230-37
C4	Monolithic, .1 μ F, 50V	230-37
C5	Not Used	
C6	Not Used	
C7	Tantalum, 10 μ F, 25V	250-42
C8	Tantalum, 10 μ F, 25V	250-42
C9	Monolithic, .1 μ F, 50V	230-37
C10	Monolithic, .1 μ F, 50V	230-37
C11	Tantalum, 10 μ F, 25V	250-42
C12	Monolithic, .1 μ F, 50V	230-37
C13	Monolithic, .1 μ F, 50V	230-37
C14	Mica, 20 pF	220-20
C15	Mica, 20 pF	220-20
C16	Mica, 20 pF	220-20
C17	Monolithic, .1 μ F, 50V	230-37
C18	Monolithic, .1 μ F, 50V	230-37
C19	Monolithic, .1 μ F, 50V	230-37
C20	Monolithic, .1 μ F, 50V	230-37
C21	Mica, 3 pF	223-3
C22	Mica, 3 pF	223-3
C23	Monolithic, .1 μ F, 50V	230-37
C24	Monolithic, .1 μ F, 50V	230-37
C25	Monolithic, .1 μ F, 50V	230-37
C26	Monolithic, .1 μ F, 50V	230-37
C27	Monolithic, .01 μ F, 100V	250-77
C28	Monolithic, .01 μ F, 100V	250-77
C29	Mica, 150 pF	220-150
C30	Tantalum, 10 μ F, 25V	250-42
C31	Monolithic, .1 μ F, 50V	230-37
C32	Tantalum, 10 μ F, 25V	250-42
C33	Monolithic, .01 μ F, 100V	250-77
C34	Monolithic, .1 μ F, 50V	230-37
C35	Monolithic, .1 μ F, 50V	230-37

CR3	Not Used	
CR4	Shottky, MBD-501	10-4
CR5	Not Used	
CR6	Shottky, MBD-501	10-4
CR7	Not Used	
CR8	Zener, 30V, 5%, 1W	10-1N4751A
CR9	Silicon, 1N4446	10-1N4446
CR10	Silicon, 1N4446	10-1N4446
CR11	Silicon, 1N4446	10-1N4446
CR12	Silicon, 1N4446	10-1N4446
CR13	Silicon, 1N4446	10-1N4446
CR14	Silicon, 1N4446	10-1N4446
CR15	Silicon, 1N4446	10-1N4446
CR16	Silicon, 1N4446	10-1N4446
CR17	Zener, 30V, 5%, 1W	10-1N4751A
CR18	Silicon, 1N4446	10-1N4446
CR19	Silicon, 1N4446	10-1N4446
CR20	Silicon, 1N4446	10-1N4446
CR21	Silicon, 1N4446	10-1N4446
CR22	Silicon, 1N4446	10-1N4446
CR23	Zener, 3.3V, 5%, .4W	10-1N746A
CR24	Silicon, 1N4446	10-1N4446
CR25	Silicon, 1N4446	10-1N4446
CR26	Silicon, 1N4446	10-1N4446
CR27	Zener, 4.7V, 5%, .4W	10-11
CR28	Silicon, 1N4446	10-1N4446

TRANSISTORS

REF. DES.	DESCRIPTION	WILTRON PART NO.
Q1	FET, J112	20-17
Q2	FET, J112	20-17
Q3	FET, J112	20-17
Q4	NPN, 2N3694	20-2N3694
Q5	NPN, 2N3694	20-2N3694
Q6	NPN, 2N3694	20-2N3694

RESISTORS

DIODES		
REF. DES.	DESCRIPTION	WILTRON PART NO.
CR1	Reference, 1N823, 6V, 0.4W	10-1N823
CR2	Shottky, MBD-501	10-4

REF. DES.	DESCRIPTION	WILTRON PART NO.
R1	MF, 1/4W, 1%, 10 k Ω	110-10k-1
R2	MF, 1/4W, 1%, 10 k Ω	110-10k-1
R3	MF, 1/4W, 1%, 10 k Ω	110-10k-1

R4	MF, 1/4W, 1%, 10 kΩ	110-10k-1
R5	MF, 1/4W, 1%, 10 kΩ	110-10k-1
R6	MF, 1/4W, 1%, 10 kΩ	110-10k-1
R7	MF, 1/4W, 1%, 1 kΩ	110-1k-1
R8	MF, 1/4W, 1%, 10 kΩ	110-10k-1
R9	MF, 1/4W, 1%, 16.2 kΩ	110-16.2k-1
R10	MF, 1/4W, 1%, 10 kΩ	110-10k-1
R11	MF, 1/4W, 1%, 16.2 kΩ	110-16.2k-1
R12	MF, 1/4W, 1%, 10 kΩ	110-10k-1
R13	Variable, 1/2W, 10%, 2 kΩ	156-2k
R14	MF, 1/4W, 1%, 1 kΩ	110-1k-1
R15	MF, 1/4W, 1%, 1 kΩ	110-1k-1
R16	MF, 1/4W, 1%, 1 kΩ	110-1k-1
R17	MF, 1/4W, 1%, 1 MΩ	110-1M-1A
R18	MF, 1/4W, 1%, 1 MΩ	110-1M-1A
R19	MF, 1/4W, 1%, 10 kΩ	110-10k-1
R20	Variable, 1/2W, 10%, 2 kΩ	156-2k
R21	MF, 1/4W, 1%, 1 kΩ	110-1k-1
R22	MF, 1/4W, 1%, 1 kΩ	110-1k-1
R23	MF, 1/4W, 1%, 1 kΩ	110-1k-1
R24	MF, 1/4W, 1%, 1 MΩ	110-1M-1A
R25	MF, 1/4W, 1%, 1 MΩ	110-1M-1A
R26	MF, 1/4W, 1%, 10 kΩ	110-10k-1
R27	Variable, 1/2W, 10%, 2 kΩ	156-2k
R28	MF, 1/4W, 1%, 1 kΩ	110-1k-1
R29	MF, 1/4W, 1%, 1 kΩ	110-1k-1
R30	MF, 1/4W, 1%, 1 kΩ	110-1k-1
R31	MF, 1/4W, 1%, 1 MΩ	110-1M-1A
R32	MF, 1/4W, 1%, 1 MΩ	110-1M-1A
R33	MF, 1/4W, 1%, 17.8 kΩ	110-17.8k-1
R34	MF, 1/4W, 1%, 10 kΩ	110-10k-1
R35	MF, 1/4W, 1%, 10 kΩ	110-10k-1
R36	MF, 1/4W, 1%, 10 kΩ	110-10k-1
R37	MF, 1/4W, 1%, 24.9 kΩ	110-24.9k-1
R38	MF, 1/4W, 1%, 100 kΩ	110-100k-1
R39	MF, 1/4W, 1%, 100 kΩ	110-100k-1
R40	MF, 1/4W, 1%, 133 kΩ	110-133k-1
R41	MF, 1/4W, 1%, 100 kΩ	110-100k-1
R42	MF, 1/4W, 1%, 17.8 kΩ	110-17.8k-1
R43	MF, 1/4W, 1%, 10 kΩ	110-10k-1
R44	MF, 1/4W, 1%, 10 kΩ	110-10k-1
R45	MF, 1/4W, 1%, 10 kΩ	110-10k-1
R46	MF, 1/4W, 1%, 24.9 kΩ	110-24.9k-1
R47	MF, 1/4W, 1%, 100 kΩ	110-100k-1
R48	MF, 1/4W, 1%, 100 kΩ	110-100k-1
R49	MF, 1/4W, 1%, 133 kΩ	110-133k-1
R50	MF, 1/4W, 1%, 100 kΩ	110-100k-1
R51	MF, 1/4W, 1%, 1 kΩ	110-1k-1
R52	MF, 1/4W, 1%, 17.8 kΩ	110-17.8k-1
R53	MF, 1/4W, 1%, 10 kΩ	110-10k-1
R54	MF, 1/4W, 1%, 10 kΩ	110-10k-1
R55	MF, 1/4W, 1%, 10 kΩ	110-10k-1
R56	MF, 1/4W, 1%, 24.9 kΩ	110-24.9k-1
R57	MF, 1/4W, 1%, 4.99 kΩ	110-4.99k-1
R58	MF, 1/4W, 1%, 200 kΩ	110-200k-1
R59	MF, 1/4W, 1%, 12.4 kΩ	110-12.4k-1
R60	MF, 1/4W, 1%, 887Ω	110-887-1
R61	MF, 1/4W, 1%, 20 kΩ	110-20k-1
R62	Variable, 1/2W, 10%, 200 kΩ	156-200k
R63	MF, 1/4W, 1%, 19.6 kΩ	110-19.6k-1
R64	MF, 1/4W, 1%, 49.9 kΩ	110-49.9k-1
R65	MF, 1/4W, 1%, 10 kΩ	110-10k-1
R66	MF, 1/4W, 1%, 1.47 kΩ	110-1.47k-1
R67	MF, 1/4W, 1%, 10 kΩ	110-10k-1

R68	MF, 1/4W, 1%, 1 kΩ	110-1k-1
R69	MF, 1/4W, 1%, 20 kΩ	110-20k-1
R70	MF, 1/4W, 1%, 301 kΩ	110-301k
R71	MF, 1/4W, 1%, 10 kΩ	110-10k-1
R72	MF, 1/4W, 1%, 100 kΩ	110-100k-1
R73	MF, 1/4W, 1%, 10 kΩ	110-10k-1
R74	MF, 1/4W, 1%, 100 kΩ	110-100k-1
R75	MF, 1/4W, 1%, 1 MΩ	110-1M-1A
R76	MF, 1/4W, 1%, 10 kΩ	110-10k-1
R77	MF, 1/4W, 1%, 20 kΩ	110-20k-1
R78	MF, 1/4W, 1%, 100 kΩ	110-100k-1
R79	MF, 1/4W, 1%, 30.1 kΩ	110-30.1k-1
R80	MF, 1/4W, 1%, 10 kΩ	110-10k-1
R81	MF, 1/4W, 1%, 100 kΩ	110-100k-1
R82	MF, 1/4W, 1%, 100 kΩ	110-100k-1
R83	MF, 1/4W, 1%, 100 kΩ	110-100k-1
R84	MF, 1/4W, 1%, 178 kΩ	110-178k-1
R85	MF, 1/4W, 1%, 27.4 kΩ	110-27.4k-1
R86	MF, 1/4W, 1%, 5.11Ω	110-5.11-1
R87	MF, 1/4W, 1%, 10 kΩ	110-10k-1
R88	MF, 1/4W, 1%, 20 kΩ	110-20k-1
R89	MF, 1/4W, 1%, 10 kΩ	110-10k-1
R90	Variable, 1/2W, 10%, 200 kΩ	156-200k
R91	MF, 1/4W, 1%, 10 kΩ	110-10k-1
R92	MF, 1/4W, 1%, 20 kΩ	110-20k-1
R93	MF, 1/4W, 1%, 1 kΩ	110-1k-1
R94	MF, 1/4W, 1%, 1 kΩ	110-1k-1
R95	MF, 1/4W, 1%, 1 kΩ	110-1k-1

INTEGRATED CIRCUITS

REF. DES.	DESCRIPTION	WILTRON PART NO.
U1	Octal Latch, 74LS374	54-41
U2	Quad NAND Gate, 74LS01	54-74LS01
U3	Op Amp, TL072CP	54-53
U4	Not Used	
U5	8 Bit DAC, AD7524	54-129
U6	8 Bit DAC, AD7524	54-129
U7	8 Bit DAC, AD7524	54-129
U8	Quad Op Amp, RC4136	54-RC4136
U9	Quad Op Amp, RC4136	54-RC4136
U10	Quad Op Amp, RC4136	54-RC4136
U11	Quad AND Gate, 74LS09	54-96
U12	Voltage Comparator, LM311	54-30
U13	Op Amp, TL072CP	54-53
U14	Op Amp, LM339	54-45
U15	Dual Flip-Flop, 74LS74	54-44
U16	Dual One-Shot, 96L02	54-96L02
U17	2-input NAND, 74LS10	54-42
U18	8 Bit ADC, ADC0804LCN	54-161
U19	Octal Latch, 74LS374	54-41

MISCELLANEOUS

REF. DES.	DESCRIPTION	WILTRON PART NO.
TP1 thru TP19	Test Points	706-44
---	Ejector, PCB	553-96

Table 6-4. A4 ALC (660-D-8004)

CAPACITORS			RESISTORS		
REF. DES.	DESCRIPTION	WILTRON PART NO.	REF. DES.	DESCRIPTION	WILTRON PART NO.
C1	Ceramic Disc, .1 μF	230-37	R1	MF, 1/4W, 1%, 10 kΩ	110-10k-1
C2	Ceramic Disc, .1 μF	230-37	R2	MF, 1/4W, 1%, 8.25 kΩ	110-8.25k-1
C3	Tantalum, 25V, 10 μF	250-42	R3	Variable, Single-Turn, 10 kΩ	156-10k
C4	Tantalum, 25V, 10 μF	250-42	R4	MF, 1/4W, 1%, 3.01 kΩ	110-3.01k-1
C5	Tantalum, 6V, 68 μF	250-58	R5	Variable, Multi-turn, 20 kΩ	157-20k
C6	Ceramic Disc, .1 μF	230-37	R6	MF, 1/4W, 1%, 3.01 kΩ	110-3.01k-1
C7	Ceramic Disc, .1 μF	230-37	R7	MF, 1/4W, 1%, 13.3 kΩ	110-13.3k-1
C8	Ceramic Disc, .1 μF	230-37	R8	MF, 1/4W, 1%, 54.9 kΩ	110-54.9k-1
C9	Ceramic Disc, .1 μF	230-37	R9	Variable, Single-Turn, 20 kΩ	156-20k
C10	Mica, 27 pF	220-27	R10	MF, 1/4W, 1%, 5.49 kΩ	110-5.49k-1
C11	Ceramic Disc, .1 μF	230-37	R11	Variable, Multi-turn, 20 kΩ	157-20k
C12	Ceramic Disc, .1 μF	230-37	R12	MF, 1/4W, 1%, 8.25 kΩ	110-8.25k-1
C13	Ceramic Disc, .1 μF	230-37	R13	MF, 1/4W, 1%, 64.9 kΩ	110-64.9k-1
C14	Ceramic Disc, .1 μF	230-37	R14	MF, 1/4W, 1%, 316 kΩ	110-316k-1
C15	Polycarbonate, .0047 μF	210-50	R15	MF, 1/4W, 1%, 20 kΩ	110-20k-1
C16	Polycarbonate, .0047 μF	210-50	R16	MF, 1/4W, 1%, 64.9 kΩ	110-64.9k-1
C17	Ceramic Disc, .1 μF	230-37	R17	MF, 1/4W, 1%, 5.49 kΩ	110-5.49k-1
C18	Ceramic Disc, .01 μF	230-11	R18	MF, 1/4W, 1%, 5.49 kΩ	110-5.49k-1
C19	Ceramic Disc, .0047 μF	230-36	R19	Variable, Multi-turn, 20 kΩ	157-20k
C20	Ceramic Disc, .02 μF	230-27	R20	MF, 1/4W, 1%, 64.9 kΩ	110-64.9k-1
C21	Ceramic Disc, .1 μF	230-37	R21	MF, 1/4W, 1%, 10 kΩ	110-10k-1
C22	Ceramic Disc, .1 μF	230-37	R22	MF, 1/4W, 1%, 20 kΩ	110-20k-1
C23	Aluminum, 63V, 47 μF	250-51	R23	MF, 1/4W, 1%, 10 kΩ	110-10k-1
C24	Not Used		R24	MF, 1/4W, 1%, 10 kΩ	110-10k-1
C25	Ceramic Disc, .01 μF	230-11	R25	MF, 1/4W, 1%, 1.07 kΩ	110-1.07k-1
			R26	MF, 1/4W, 1%, 19.6 kΩ	110-19.6k-1
			R27	MF, 1/4W, 1%, 12.1 kΩ	110-12.1k-1
			R28	MF, 1/4W, 1%, 10.2 kΩ	110-10.2k-1
			R29	MF, 1/4W, 1%, 16.5 kΩ	110-16.5k-1
			R30	MF, 1/4W, 1%, 51.1Ω	110-51.1-1
			R31	MF, 1/4W, 1%, 51.1Ω	110-51.1-1
			R32	MF, 1/4W, 1%, 51.1Ω	110-51.1-1
			R33	MF, 1/4W, 1%, 511Ω	110-511-1
			R34	MF, 1/4W, 1%, 100 kΩ	110-100k-1
			R35	MF, 1/4W, 1%, 10 kΩ	110-10k-1
			R36	MF, 1/4W, 1%, 10 kΩ	110-10k-1
			R37	MF, 1/4W, 1%, 511Ω	110-511-1
			R38	MF, 1/4W, 1%, 100 kΩ	110-100k-1
			R39	MF, 1/4W, 1%, 10 kΩ	110-10k-1
			R40	MF, 1/4W, 0.1%, 900Ω	113-900-0.1
			R41	MF, 1/4W, 0.1%, 900Ω	113-900-0.1
			R42	MF, 1/4W, 1%, 12.4 kΩ	110-12.4k-1
			R43	MF, 1/4W, 1%, 261Ω	110-261-1
			R44	MF, 1/4W, 1%, 261Ω	110-261-1
			R45	MF, 1/4W, 1%, 12.4 kΩ	110-12.4k-1
			R46	MF, 1/4W, 1%, 604Ω	110-604-1
			R47	MF, 1/4W, 1%, 576Ω	110-576-1
			R48	MF, 1/4W, 1%, 12.4 kΩ	110-12.4k-1
			R49	MF, 1/4W, 1%, 1.82 kΩ	110-1.82k-1
			R50	MF, 1/4W, 1%, 953Ω	110-953-1
			R51	MF, 1/4W, 1%, 4.99 kΩ	110-4.99k-1
			R52	MF, 1/4W, 1%, 54.9 kΩ	110-54.9k-1
			R53	MF, 1/4W, 1%, 15 kΩ	110-15k-1
			R54	MF, 1/4W, 1%, 12.4 kΩ	110-12.4k-1
			R55	MF, 1/4W, 1%, 487Ω	110-487-1
			R56	MF, 1/4W, 1%, 464Ω	110-464-1
			R57	MF, 1/4W, 1%, 12.4 kΩ	110-12.4k-1
			R58	MF, 1/4W, 1%, 2.43 kΩ	110-2.43k-1
			R59	MF, 1/4W, 1%, 2.05 kΩ	110-2.05k-1
			R60	MF, 1/4W, 1%, 12.4 kΩ	110-12.4k-1
			R61	MF, 1/4W, 1%, 12.4 kΩ	110-12.4k-1
			R62	MF, 1/4W, 0.1%, 20 kΩ	113-20k-0.1
			R63	MF, 1/4W, 0.1%, 20 kΩ	113-20k-0.1
			R64	MF, 1/4W, 0.1%, 20 kΩ	113-20k-0.1
			R65	MF, 1/4W, 0.1%, 20 kΩ	113-20k-0.1

DIODES		
REF. DES.	DESCRIPTION	WILTRON PART NO.
CR1	Silicon, 1N4446	10-1N4446
CR2	Silicon, 1N4446	10-1N4446
CR3	Silicon, 1N4446	10-1N4446
CR4	Silicon, 1N4446	10-1N4446
CR5	Silicon, 1N4446	10-1N4446
CR6	Silicon, 1N4446	10-1N4446
CR7	Reference, 6.2V, 1N823	10-1N823
CR8	Zener, 5.1V, 0.4W, 1N751A	10-1N751A
CR9	Silicon, 1N4446	10-1N4446
CR10	Silicon, 1N4446	10-1N4446
CR11	Silicon, 1N4446	10-1N4446
CR12	Silicon, 1N4446	10-1N4446
CR13	Silicon, 1N4446	10-1N4446
CR14	Silicon, 1N4446	10-1N4446
CR15	MBD-501	10-4
CR16	Silicon, 1N4446	10-1N4446
CR17	Silicon, 1N4446	10-1N4446
CR18	MBD-501	10-4
CR19	Silicon, 1N4446	10-1N4446
CR20	Silicon, 1N4446	10-1N4446

TRANSISTORS		
REF. DES.	DESCRIPTION	WILTRON PART NO.
Q1	NPN, .5W, 2N2222A	20-2N2222A
Q2	PNP, .4W, 2N4249	20-2N4249
Q3	PNP, .4W, 2N4249	20-2N4249
Q4	NPN, .4W, 2N3694	20-2N3694
Q5	NPN, .4W, 2N3694	20-2N3694

R66	Variable, Multi-turn, 2 k Ω	157-2k
R67	MF, 1/4W, 1%, 2.37 k Ω	110-2.37k-1
R68	Variable, Multi-turn, 2 k Ω	157-2k
R69	MF, 1/4W, 1%, 1.47 k Ω	110-1.47k-1
R70	Variable, Multi-turn, 2 k Ω	157-2k
R71	MF, 1/4W, 1%, 6.19 k Ω	110-6.19k-1
R72	Variable, Multi-turn, 2 k Ω	157-2k
R73	MF, 1/4W, 1%, 7.87 k Ω	110-7.87k-1
R74	MF, 1/4W, 1%, 10 k Ω	110-10k-1
R75	MF, 1/4W, 1%, 10 k Ω	110-10k-1
R76	CC, 1/4W, 5%, 10 M Ω	101-10M-5
R77	MF, 1/4W, 1%, 133 k Ω	110-133k-1
R78	MF, 1/4W, 1%, 2.49 k Ω	110-2.49k-1
R79	MF, 1/4W, 1%, 8.66 k Ω	110-8.66k-1
R80	Variable, Single-Turn, 2 k Ω	156-2k
R81	MF, 1/4W, 1%, 6.49 k Ω	110-6.49k-1
R82	Variable, Single-Turn, 2 k Ω	156-2k
R83	MF, 1/4W, 1%, 11.3 k Ω	110-11.3k-1
R84	Variable, Single-Turn, 2 k Ω	156-2k
R85	MF, 1/4W, 1%, 8.25 k Ω	110-8.25k-1
R86	Variable, Single-Turn, 2 k Ω	156-2k
R87	MF, 1/4W, 1%, 8.66 k Ω	110-8.66k-1
R88	Variable, Single-Turn, 2 k Ω	156-2k
R89	MF, 1/4W, 1%, 11 k Ω	110-11k-1
R90	Variable, Single-Turn, 5 k Ω	156-5k
R91	MF, 1/4W, 1%, 1 M Ω	110-1M-1A
R92	MF, 1/4W, 1%, 1 M Ω	110-1M-1A
R93	MF, 1/4W, 1%, 10 k Ω	110-10k-1
R94	MF, 1/4W, 1%, 1 M Ω	110-1M-1A
R95	MF, 1/4W, 1%, 1 M Ω	110-1M-1A
R96	MF, 1/4W, 1%, 1 M Ω	110-1M-1A
R97	MF, 1/4W, 1%, 10 k Ω	110-10k-1
R98	MF, 1/4W, 1%, 1 M Ω	110-1M-1A
R99	MF, 1/4W, 1%, 26.7 k Ω	110-26.7k-1
R100	MF, 1/4W, 1%, 42.2 k Ω	110-42.2k-1
R101	MF, 1/4W, 1%, 30.1 k Ω	110-30.1k-1
R102	MF, 1/4W, 1%, 30.1 k Ω	110-30.1k-1
R103	Variable, Multi-turn, 5 k Ω	157-5k
R104	MF, 1/4W, 1%, 301 k Ω	110-301k-1
R105	MF, 1/4W, 1%, 10 k Ω	110-10k-1
R106	MF, 1/4W, 1%, 9.76 k Ω	110-9.76k-1
R107	MF, 1/4W, 1%, 10 k Ω	110-10k-1
R108	MF, 1/4W, 1%, 511 k Ω	110-511k-1
R109	MF, 1/4W, 1%, 10 k Ω	110-10k-1
R110	MF, 1/4W, 1%, 10 k Ω	110-10k-1
R111	MF, 1/4W, 1%, 10 k Ω	110-10k-1
R112	MF, 1/4W, 1%, 10 k Ω	110-10k-1
R113	MF, 1/4W, 1%, 20 k Ω	110-20k-1
R114	MF, 1/4W, 1%, 20 k Ω	110-20k-1
R115	Variable, Single-Turn, 20 k Ω	156-20k
R116	MF, 1/4W, 1%, 16.5 k Ω	110-16.5k-1
R117	MF, 1/4W, 1%, 7.5 k Ω	110-7.5k-1
R118	MF, 1/4W, 1%, 5.11 k Ω	110-5.11k-1
R119	MF, 1/4W, 1%, 2 k Ω	110-2k-1
R120	MF, 1/4W, 1%, 15 k Ω	110-15k-1
R121	MF, 1/4W, 1%, 2 k Ω	110-2k-1
R122	MF, 1/4W, 1%, 511 Ω	110-511-1
R123	Variable, Single-Turn, 2 k Ω	156-2k
R124	Variable, Single-Turn, 2 k Ω	156-2k
R125	MF, 1/4W, 1%, 1 k Ω	110-1k-1
R126	MF, 1/4W, 1%, 1 k Ω	110-1k-1
R127	MF, 1/4W, 1%, 100 k Ω	110-100k-1
R128	MF, 1/4W, 1%, 10 k Ω	110-10k-1

R129	MF, 1/4W, 1%, 10 k Ω	110-10k-1
R130	MF, 1/4W, 1%, 4.02 k Ω	110-4.02k-1
R131	MF, 1/4W, 1%, 1 k Ω	110-1k-1
R132	MF, 1/4W, 1%, 4.02 k Ω	110-4.02k-1
R133	MF, 1/4W, 1%, 4.02 k Ω	110-4.02k-1
R134	MF, 1/4W, 1%, 20 k Ω	110-20k-1
R135	MF, 1/4W, 1%, 4.02 k Ω	110-4.02k-1
R136	MF, 1/4W, 1%, 1 k Ω	110-1k-1
R137	MF, 1/4W, 1%, 1 k Ω	110-1k-1
R138	MF, 1/4W, 1%, 4.99 k Ω	110-4.99k-1
R139	MF, 1/4W, 1%, 649 Ω	110-649-1
R140	MF, 1/4W, 1%, 4.99 k Ω	110-4.99k-1
R141	MF, 1/4W, 1%, 887 Ω	110-887-1
R142	Variable, Single-Turn, 20 k Ω	156-20k
R143	MF, 1/4W, 1%, 4.99 k Ω	110-4.99k-1
R144	MF, 1/4W, 1%, 15 k Ω	110-15k-1
R145	MF, 1/4W, 1%, 1 k Ω	110-1k-1
R146	MF, 1/4W, 1%, 10 k Ω	110-10k-1
R147	MF, 1/4W, 1%, 3.01 k Ω	110-3.01k-1
R148	MF, 1/4W, 1%, 10 k Ω	110-10k-1
RP1	Package, 1 k Ω	123-1

INTEGRATED CIRCUITS

REF. DES.	DESCRIPTION	WILTRON PART NO.
U1	Quad NAND, 74LS00	54-74LS00
U2	Hex Inverter, 74LS04	54-74LS04
U3	Triple NAND, 74LS10	54-42
U4	Op Amp, LF356N	50-9
U5	Switch, DG201	54-24
U6	Op Amp, LF356N	50-9
U7	Op Amp, LF356N	50-9
U8	Op Amp, TL072	54-53
U9	Op Amp, TL072	54-53
U10	Op Amp, TL072	54-53
U11	Quad Comparator, MC3302P	54-MC3302P
U12	Transistor Array, CA3054	54-6
U13	Transistor Array, CA3054	54-6
U14	Op Amp, LF356N	50-9
U15	Transistor Array, CA3054	54-6
U16	Op Amp, TL072	54-53
U17	Switch, DG201	54-24
U18	Op Amp, TL074	54-132
U19	Op Amp, TL074	54-132
U20	Switch, DG201	54-24
U21	Op Amp, LF356N	50-9
U22	8 Bit DAC, AD 7524	54-129
U23	Quad Schmitt NAND, 74LS132	54-74LS132
U24	Octal Latch, 74LS374	54-41
U25	Quad Transparent Latch, 74LS75	54-74LS75

MISCELLANEOUS

REF. DES.	DESCRIPTION	WILTRON PART NO.
TP1 thru TP7	Pin, Test Point	706-44
---	Ejector, PC Board	553-96

Table 6-5. A5 Frequency Instruction (660-D-8005)

<u>CAPACITORS</u>					
REF DES.	DESCRIPTION	WILTRON PART NO.			
C1	Mica, 100 pF	220-100	d. 6621A-40		SPCL-A-13074
C2	Mica, 100 pF	220-100	e. 6629A		SPCL-A-11587
C3	Disc Ceramic, 0.001 μ F	230-30	f. 6629A-40		SPCL-A-13081
C4	Monolithic, 0.1 μ F	230-37	g. 6637A		660-A-8145-3
C5	Tantalum, 4.7 μ F, 35V	250-39	h. 6637A-40		660-A-8145-3
C6	Monolithic, 0.1 μ F	230-37	i. 6638A		660-A-8145-4
C7	Tantalum, 4.7 μ F, 35V	250-39	j. 6642A		SPCL-A-11623
C8	Monolithic, 0.1 μ F	230-37	k. 6647A		660-A-8145-3
C9	Monolithic, 0.1 μ F	230-37	l. 6648A		660-A-8145-4
C10	Monolithic, 0.1 μ F	230-37	m. 6653A		660-A-8145-5
C11	Monolithic, 0.1 μ F	230-37	n. 6659A		660-A-8145-5
C12	Tantalum, 4.7 μ F, 35V	250-39	A2	Resistor Pack	
C13	Tantalum, 4.7 μ F, 35V	250-39	a. 6609A		660-A-12632-1
C14	Monolithic, 0.1 μ F	230-37	b. 6617A		660-A-12732-2
C15	Monolithic, 0.1 μ F	230-37	c. 6621A		SPCL-B-13091-5
C16	Tantalum, 4.7 μ F, 35V	250-39	d. 6621A-40		SPCL-B-13091-5
C17	Tantalum, 4.7 μ F, 35V	250-39	e. 6629A		SPCL-B-13091-9
C18	Monolithic, 0.1 μ F	230-37	f. 6629A-40		SPCL-B-13091-9
C19	Monolithic, 0.1 μ F	230-37	g. 6637A		660-A-12632-3
C20	Tantalum, 4.7 μ F, 35V	250-39	h. 6637A-40		660-A-12632-3
C21	Tantalum, 4.7 μ F, 35V	250-39	i. 6638A		660-A-12632-5
C22	Monolithic, 0.1 μ F	230-37	j. 6642A		SPCL-B-13091-13
C23	Monolithic, 0.1 μ F	230-37	k. 6647A		660-A-12632-4
C24	Monolithic, 0.1 μ F	230-37	l. 6648A		660-A-12632-6
C25	Disc Ceramic, 0.001 μ F	230-30	m. 6653A		660-A-12632-9
C26	Mica, 100 pF	220-100	n. 6659A		660-A-12632-10
C27	Disc Ceramic, 0.001 μ F	230-30	RP1	Resistor Pack, 10 k Ω	123-6
			R1	MF, 1/4W, 1%, 10 k Ω	110-10k-1
			R2	MF, 1/4W, 1%, 2.37 k Ω	110-2.37k-1
			R3	MF, 1/4W, 1%, 2.37 k Ω	110-2.37k-1
			R4	MF, 1/4W, 1%, 3.92 k Ω	110-3.92k-1
			R5	MF, 1/4W, 1%, 392 Ω	110-392-1
			R6	Part of A2	
			R7	Part of A2	
			R8	Variable, Multi-turn, 50 k Ω	157-50k
			R9	MF, 1/4W, 1%, 348 k Ω	110-348k-1
			R10	Variable, Multi-turn, 20 k Ω	157-20k
			R11	MF, 1/4W, 0.1%, 30 k Ω	113-30k-0.1
			R12	MF, 1/4W, 1%, 511 Ω	110-511-1
			R13	Variable, Single-Turn, 500 Ω	156-500
			R14	MF, 1/4W, 1%, 10 k Ω	110-10k-1
			R15	MF, 1/4W, 0.1%, 30 k Ω	113-30k-0.1
			R16	MF, 1/4W, 1%, 10 k Ω	110-10k-1
			R17	MF, 1/4W, 1%, 10 k Ω	110-10k-1
			R18	Part of A2	
			R19	Part of A2	
			R20	Part of A2	
			R21	Part of A2	
			R22	Part of A2	
			R23	MF, 1/4W, 0.1%, 30 k Ω	113-30k-0.1
			R24	MF, 1/4W, 1%, 511 Ω	110-511-1
			R25	MF, 1/4W, 1%, 1 k Ω	110-1k-1
			R26	MF, 1/4W, 0.1%, 10 k Ω	113-10k-0.1
			R27	MF, 1/4W, 0.1%, 10 k Ω	113-10k-0.1
			R28	MF, 1/4W, 0.1%, 10 k Ω	113-10k-0.1
			R29	Variable, Multi-turn, 500 Ω	157-500
			R30	MF, 1/4W, 0.1%, 30 k Ω	113-30k-0.1
			R31	MF, 1/4W, 0.1%, 10 k Ω	113-10k-0.1
			R32	MF, 1/4W, 0.1%, 10 k Ω	113-10k-0.1
			R33	MF, 1/4W, 0.1%, 10 k Ω	113-10k-0.1
			R34	MF, 1/4W, 0.1%, 10 k Ω	113-10k-0.1
			R35	MF, 1/4W, 1%, 27.4 k Ω	110-27.4k-1
			R36	MF, 1/4W, 0.1%, 10 k Ω	113-10k-0.1
			R37	Part of A2	
			R38	Part of A2	
			R39	MF, 1/4W, 1%, 511 Ω	110-511-1
			R40	Variable, Multi-turn, 20k	157-20k
			R41	MF, 1/4W, 0.1%, 10 k Ω	113-10k-0.1

<u>DIODES</u>					
REF DES.	DESCRIPTION	WILTRON PART NO.			
CR1	Schottky, MBD-501	10-4			
CR2	Schottky, MBD-501	10-4			
CR3	Silicon, 1N4446	10-1N4446			
CR4	Silicon, 1N4446	10-1N4446			
CR5	Zener, 12V, 0.4W, 1N759A	10-1N759A			
CR6	Reference, 6.2V, 1N823	10-1N823			
CR7	Silicon, 1N4446	10-1N4446			
CR8	Silicon, 1N4446	10-1N4446			
CR9	Zener, 11V, 1N962B	10-1N962B			
CR10	Zener, 11V, 1N962B	10-1N962B			

<u>TRANSISTORS</u>					
REF DES.	DESCRIPTION	WILTRON PART NO.			
Q1	PNP, 2N6041	20-2N6041			
Q2	PNP, 2N2907A	20-2N2907A			
Q3	NPN, 2N2222A	20-2N2222A			

<u>RESISTORS</u>					
REF. DES.	DESCRIPTION	WILTRON PART NO.			
A1	Resistor Pack				
	a. 6609A	660-A-8145-1			
	b. 6617A	660-A-8145-2			
	c. 6621A	SPCL-A-11552			

R42	MF, 1/4W, 1%, 10 kΩ	110-10k-1
R43	MF, 1/4W, 0.1%, 10 kΩ	113-10k-0.1
R44	MF, 1/4W, 0.1%, 10 kΩ	113-10k-0.1
R45	MF, 1/4W, 0.1%, 10 kΩ	113-10k-0.1
R46	Variable, Multi-turn, 20k	157-20k
R47	MF, 1/4W, 1%, 10Ω	110-10-1
R48	MF, 1/4W, 1%, 1 kΩ	110-1k-1
R49	Variable, Single-Turn, 1 kΩ	157-1k
R50	MF, 1/4W, 1%, 6.49 kΩ	110-6.49k-1
R51	MF, 1/4W, 1%, 4.32 kΩ	110-4.32k-1
R52	MF, 1/4W, 1%, 422Ω	110-422-1
R53	MF, 1/4W, 1%, 10 kΩ	110-10k-1
R54	MF, 1/4W, 1%, 1 kΩ	110-1k-1
R55	Variable, Single-Turn, 1 kΩ	157-1k
R56	MF, 1/4W, 1%, 3.83 kΩ	110-3.83k-1
R57	MF, 1/4W, 1%, 1.87 kΩ	110-1.87k-1
R58	MF, 1/4W, 1%, 10Ω	110-10-1
R59	MF, 1/4W, 0.1%, 10 kΩ	113-10k-0.1
R60	MF, 1/4W, 1%, 3.92 kΩ	110-3.92k-1
R61	MF, 1/4W, 1%, 10 kΩ	110-10k-1
R62	Variable, Single-Turn, 5k	156-5k
R63	MF, 1/4W, 1%, 10 kΩ	110-10k-1
R64	MF, 1/4W, 1%, 10 kΩ	110-10k-1
R65	MF, 1/4W, 1%, 10 kΩ	110-10k-1
R66	MF, 1/4W, 1%, 10 kΩ	110-10k-1
R67	MF, 1/4W, 1%, 100 kΩ	110-100k-1
R68	Variable, Multi-turn, 2 kΩ	157-2k
R69	Variable, Multi-turn, 2 kΩ	157-2k
R70	MF, 1/4W, 1%, 49.9 kΩ	110-49.9k-1
R71	Part of A2	
R72	Part of A2	
R73	Part of A2	
R74	MF, 1/4W, 1%, 49.9 kΩ	110-49.9k-1
R75	Variable, Single-Turn, 5 kΩ	156-5k
R76	MF, 1/4W, 1%, 3.16 kΩ	110-3.16k-1
R77	Variable, Single-Turn, 5 kΩ	156-5k
R78	MF, 1/4W, 1%, 2.49 kΩ	110-2.49k-1
R79	Variable, Single-Turn, 5 kΩ	156-5k
R80	MF, 1/4W, 1%, 6.81 kΩ	110-6.81k-1
R81	Variable, Single-Turn, 5 kΩ	156-5k
R82	MF, 1/4W, 1%, 3.01 kΩ	110-3.01k-1
R83	MF, 1/4W, 1%, 10 kΩ	110-10k-1
R84	MF, 1/4W, 1%, 10 kΩ	110-10k-1
R85	Part of A2	
R86	Part of A2	
R87	MF, 1/4W, 1%, 49.9 kΩ	110-49.9k-1
R88	MF, 1/4W, 1%, 10 kΩ	110-10k-1
R89	MF, 1/4W, 1%, 10 kΩ	110-10k-1

INTEGRATED CIRCUITS

REF. DES.	DESCRIPTION	WILTRON PART NO.
U1	Hex Inverter, 74LS00	54-74LS00

U2	8 Bit Multiplying DAC, MC1408L8	54-148
U3	Op Amp, 356	50-9
U4	8 Bit Multiplying DAC, MC1408L8	54-148
U5	Octal Latch, 74LS374	54-41
U6	Op Amp, OP05	50-87
U7	16 Bit DAC	54-150
U8	Octal Latch, 74LS374	54-41
U9	Octal Latch, 74LS374	54-41
U10	Dual FET-Input Op Amp, TL072	54-53
U11	Dual Analog Switch, DG200BA	50-DG200BA
U12	Op Amp, 301A	50-8
U13	Op Amp, 356	50-9
U14	Op Amp, 356	50-9
U15	Octal Latch, 74LS374	54-41
U16	Octal Latch, 74LS374	54-41
U17	Octal Latch, 74LS374	54-41
U18	Octal Latch, 74LS374	54-41
U19	12 Bit Multiplying DAC	54-149
U20	Op Amp, 356	50-9
U21	Dual FET-Input Op Amp, TL072	54-53
U22	Quad Analog Switch, LF13201N	54-20
U23	Op Amp, 356	50-9
U24	12 Bit Multiplying DAC	54-149
U25	Op Amp, 356	50-9
U26	Op Amp, OP05	50-87
U27	Dual FET-Input Op Amp, TL072	54-53
U28	Quad Analog Switch, LF13201N	54-20
U29	Triple NAND, 74LS10	54-42
U30	Op AMP, 356	50-9
U31	Quad D Flip-Flop, 74LS175	54-74LS175
U32	Octal Latch, 74LS374	54-41
U33	Quad Analog-Switch, LF13201N	54-20
U34	Quad Analog-Switch, LF13201N	54-20
U35	Dual FET-Input Op Amp, TL074	54-132

MISCELLANEOUS

REF. DES.	DESCRIPTION	WILTRON PART NO.
P2	Connector, 3-Pin	551-238
S1	Switch, DPDT	420-14
TP1 thru TP10	Pin, Test Point	706-44
----	Socket, I.C., 14-Pin	553-63
----	Socket, I.C. 24-Pin	553-67
----	Ejector, P.C. Board	553-96

Table 6-6. A6 HET/YIG Driver, .01 - 2 GHz, 6609A (660-D-8007-4)

CAPACITORS		
REF. DES.	DESCRIPTION	WILTRON PART NO.
C1	Monolithic, .1 μF	230-37
C2	Monolithic, .1 μF	230-37
C3	Tantalum, 35V, 6.8 μF	250-41
C4	Monolithic, .1 μF	230-37
C5	Tantalum, 35V, 6.8 μF	250-41

C6	Monolithic, .1 μF	230-37
C7	Tantalum, 35V, 6.8 μF	250-41
C8	Monolithic, .1 μF	230-37
C9	Ceramic, .01 μF	230-11
C10	Ceramic, .001 μF	230-30
C11	Tantalum, 1 μF, 35V	250-19
C12	Tantalum, 1 μF, 35V	250-19
C13	Monolithic, 1 μF	230-41
C14	Monolithic, .1 μF	230-37
C15	Mica, 300 pF	220-300

C16	Tantalum, 35V, 6.8 μ F	250-41
C18	Ceramic, .01 μ F	230-11
C19	Tantalum, 35V, 6.8 μ F	250-41
C21	Mica, 8.2 pF	221-8.2
C22	Mica, 820 pF	220-820
C23	Ceramic, .01 μ F	230-11
C24	Ceramic, .01 μ F	230-11
C25	Ceramic, .01 μ F	230-11

DIODES

REF. DES.	DESCRIPTION	WILTRON PART NO.
CR1	Silicon, 1N4446	10-1N4446
CR2	Silicon, 1N4446	10-1N4446
CR3	Silicon, 1N4446	10-1N4446
CR4	Silicon, SI2	10-SI2
CR5	Zener, 24V, 1W, 1N4749A	10-1N4749A
CR6	Silicon, 1N4446	10-1N4446
CR7	Silicon, 1N4446	10-1N4446
CR8	Zener, 6.8V, 1W, 1N4736A	10-1N4736A
CR9	Silicon, 1N4446	10-1N4446
CR10	Silicon, 1N4446	10-1N4446
CR11	Silicon, 1N4446	10-1N4446

TRANSISTORS

REF. DES.	DESCRIPTION	WILTRON PART NO.
Q1	PNP, MPSA92	20-MPSA92
Q2	PNP, MPSA92	20-MPSA92
Q3	NPN, 2N2222A	20-2N2222A
Q4	PNP, 2N2907A	20-2N2907A
Q5	NPN, 2N2222A	20-2N2222A
Q6	NPN, 2N3694	20-2N3694
Q7	NPN, MPSU04	20-MPSU04
Q8	PNP, 2N2907A	20-2N2907A
Q9	NPN, 2N2222A	20-2N2222A

RESISTORS

REF. DES.	DESCRIPTION	WILTRON PART NO.
R1	Variable, 1-Turn, 20 k Ω	156-20K
R2	MF, 1/4W, 1%, 61.9 k Ω	110-61.9k-1
R3	Variable, 10-Turn 1 k Ω	157-1k
R4	MF, 1/4W, 1%, 11 k Ω	110-11k-1
R5	MF, 1/4W, 1%, 5.11 k Ω	110-5.11k-1
R6	MF, 1/4W, 1%, 5.11 Ω	110-5.11-1
R7	Variable, 10-Turn, 1 k Ω	157-1k
R8	MF, 1/4W, 1%, 11 k Ω	110-11k-1
R9	Variable, 10-Turn, 20 k Ω	157-20k
R10	MF, 1/4W, 1%, 23.7 k Ω	110-23.7k-1
R11	MF, 1/4W, 1%, 511 Ω	110-511-1
R12	MF, 1/4W, 1%, 1 k Ω	110-1k-1
R13	MF, 1/4W, 1%, 9.09 k Ω	110-9.09k-1
R14	MF, 1/4W, 1%, 1.10 k Ω	110-1.10k-1
R15	WW, 5W, 5 Ω	131-3
R16	MF, 1/4W, 1%, 511 Ω	110-511-1

R17	MF, 1/4W, 1%, 5.11 k Ω	110-5.11k-1
R18	MF, 1/4W, 1%, 5.11 k Ω	110-5.11k-1
R19	MF, 1/4W, 1%, 1 k Ω	110-1k-1
R20	MF, 1/4W, 1%, 10 k Ω	110-10k-1
R21	MF, 1/4W, 1%, 23.7 k Ω	110-23.7k-1
R22	MF, 1/4W, 1%, 1 k Ω	110-1k-1
R23	MF, 1/4W, 1%, 121 Ω	110-121-1
R24	MF, 1/4W, 1%, 1 k Ω	110-1k-1
R25	MF, 1/4W, 1%, 7.5 k Ω	110-7.5k-1
R26	MF, 1/4W, 1%, 5.11 Ω	110-5.11-1
R27	MF, 1/4W, 1%, 5.11 k Ω	110-5.11k-1
R41	MF, 1/4W, 1%, 10 k Ω	110-10k-1
R42	MF, 1/4W, 1%, 15 k Ω	110-15k-1
R43	MF, 1/4W, 1%, 11 k Ω	110-11k-1
R44	MF, 1/4W, 1%, 3.24 k Ω	110-3.24k-1
R45	MF, 1/4W, 1%, 3.24 k Ω	110-3.24k-1
R46	MF, 1/4W, 1%, 1 k Ω	110-1k-1
R47	MF, 1/4W, 1%, 511 Ω	110-511-1
R48	MF, 1/4W, 1%, 5.11 Ω	110-5.11-1
R49	MF, 1/4W, 1%, 5.11 Ω	110-5.11-1
R50	MF, 1/4W, 1%, 2.74 k Ω	110-2.74k-1
R51	MF, 1/4W, 1%, 15 k Ω	110-15k-1
R66	Variable, 1-Turn, 500 k Ω	156-500k
R67	MF, 1/4W, 1%, 20 k Ω	110-20k-1
R70	MF, 1/4W, 1%, 15 k Ω	110-15k-1
R71	MF, 1/4W, 1%, 1.30 k Ω	110-1.30k-1
R72	MF, 1/4W, 1%, 8.87 k Ω	110-8.87k-1
R73	MF, 1/4W, 1%, 3.40 k Ω	110-3.40k-1
R74	MF, 1/4W, 1%, 5.11 k Ω	110-5.11k-1
R75	MF, 1/4W, 1%, 301 Ω	110-301-1
R76	MF, 1/4W, 1%, 1.21 k Ω	110-1.21k-1
R77	MF, 1/4W, 1%, 17.8 k Ω	110-17.8k-1
R78	MF, 1/4W, 1%, 511 Ω	110-511-1
R79	MF, 1/4W, 1%, 10 k Ω	110-10k-1
R80	MF, 1/4W, 1%, 10 k Ω	110-10k-1
R81	MF, 1/4W, 1%, 23.7 k Ω	110-23.7k-1
R82	MF, 1/4W, 1%, 2 k Ω	110-2k-1
R88	Variable, 1-Turn, 20 Ω	156-20
R89	MF, 1/4W, 1%, 15 k Ω	110-15k-1

INTEGRATED CIRCUITS

REF. DES.	DESCRIPTION	WILTRON PART NO.
U4	Op-Amp, OP05	54-87
U5	2k x 8 EPROM, 2716	Not Field-Replaceable
U8	Dual Op-Amp, TL072	54-53
U10	Input NAND Gate, 74LS10	54-42

MISCELLANEOUS

REF. DES.	DESCRIPTION	WILTRON PART NO.
---	Ejector, P.C. Board	553-96
TP1 thru TP5	Pin, Test Point	706-44
K1	Relay, 2 Form C	690-28
---	Socket, I.C., 24-Pin	553-67

Table 6-7. A6 HET/YIG Driver, 2-8 GHz, 6617A (660-D-8007-6)

<u>CAPACITORS</u>			<u>RESISTORS</u>		
REF. DES.	DESCRIPTION	WILTRON PART NO.	REF. DES.	DESCRIPTION	WILTRON PART NO.
C1	Monolithic, .1 μ F	230-37	R1	Variable, 1-Turn, 20 k Ω	156-20K
C2	Monolithic, .1 μ F	230-37	R2	MF, 1/4W, 1%, 61.9 k Ω	110-61.9k-1
C3	Tantalum, 35V, 6.8 μ F	250-41A	R3	Variable, 10-Turn 1 k Ω	157-1k
C4	Monolithic, .1 μ F	230-37	R4	MF, 1/4W, 1%, 11 k Ω	110-11k-1
C5	Tantalum, 35V, 6.8 μ F	250-41A	R5	Variable, 10-Turn, 50 k Ω	157-50k
C6	Monolithic, .1 μ F	230-37	R6	CC, 1/4W, 5%, 3.6 M Ω	101-3.6M-5
C7	Tantalum, 35V, 6.8 μ F	250-41A	R7	Variable, 10-Turn, 1 k Ω	157-1k
C8	Monolithic, .1 μ F	230-37	R8	MF, 1/4W, 1%, 11 k Ω	110-11k-1
C9	Ceramic, .01 μ F	230-11	R9	Variable, 10-Turn, 20 k Ω	157-20k
C10	Ceramic, .001 μ F	230-30	R10	MF, 1/4W, 1%, 100 k Ω	110-100k-1
C11	Tantalum, 1 μ F, 35V	250-19	R11	MF, 1/4W, 1%, 100 k Ω	110-100k-1
C12	Tantalum, 1 μ F, 35V	250-19	R12	Variable, 10-Turn, 5 k Ω	157-5k
C13	Monolithic, 1 μ F	230-41	R13	MF, 1/4W, 1%, 56.3 k Ω	110-56.3k-1
C14	Monolithic, .1 μ F	230-37	R14	MF, 1/4W, 1%, 4.22 k Ω	110-4.22k-1
C15	Mica, 300 pF	220-300	R15	WW, 5W, 5 Ω	131-3
C16	Tantalum, 35V, 6.8 μ F	250-41A	R16	MF, 1/4W, 1%, 100 k Ω	110-100k-1
C17	Ceramic, .001 μ F	230-30	R17	MF, 1/4W, 1%, 3.24 k Ω	110-3.24k-1
C18	Ceramic, .01 μ F	230-11	R18	MF, 1/4W, 1%, 10 k Ω	110-10k-1
C19	Tantalum, 35V, 4.7 μ F	250-39	R19	MF, 1/4W, 1%, 10 k Ω	110-10k-1
C21	Mica, 8.2 pF	221-8.2	R20	MF, 1/4W, 1%, 10 k Ω	110-10k-1
C22	Ceramic, .01 μ F	230-11	R21	MF, 1/4W, 1%, 23.7 k Ω	110-23.7k-1
C23	Ceramic, .01 μ F	230-11	R22	MF, 1/4W, 1%, 1 k Ω	110-1k-1
C24	Ceramic, .01 μ F	230-11	R23	MF, 1/4W, 1%, 121 Ω	110-121-1
C25	Ceramic, .01 μ F	230-11	R24	MF, 1/4W, 1%, 1 k Ω	110-1k-1
C26	Monolithic, .1 μ F	230-37	R25	MF, 1/4W, 1%, 7.5 k Ω	110-7.5k-1
			R26	MF, 1/4W, 1%, 5.11 Ω	110-5.11-1
			R27	MF, 1/4W, 1%, 5.11 k Ω	110-5.11k-1
			R28	MF, 1/4W, 1%, 18.7 k Ω	110-18.7k-1
			R29	MF, 1/4W, 1%, 562 k Ω	110-562k-1
			R30	MF, 1/4W, 1%, 18.7 k Ω	110-18.7k-1
			R31	MF, 1/4W, 1%, 18.7 k Ω	110-18.7k-1
			R32	MF, 1/4W, 1%, 18.7 k Ω	110-18.7k-1
			R33	MF, 1/4W, 1%, 18.7 k Ω	110-18.7k-1
			R34	MF, 1/4W, 1%, 18.7 k Ω	110-18.7k-1
			R35	MF, 1/4W, 1%, 562 k Ω	110-562k-1
			R36	Variable, 10-Turn, 2 k Ω	157-2k
			R37	MF, 1/4W, 1%, 20 k Ω	110-20k-1
			R38	Variable, 10-Turn, 50 k Ω	157-50k
			R39	MF, 1/4W, 1%, 205 k Ω	110-205k-1
			R40	MF, 1/4W, 1%, 75 k Ω	110-75k-1
			R41	MF, 1/4W, 1%, 10 k Ω	110-10k-1
			R42	MF, 1/4W, 1%, 15 k Ω	110-15k-1
			R43	MF, 1/4W, 1%, 11 k Ω	110-11k-1
			R44	MF, 1/4W, 1%, 3.24 k Ω	110-3.24k-1
			R45	MF, 1/4W, 1%, 3.24 k Ω	110-3.24k-1
			R46	MF, 1/4W, 1%, 1 k Ω	110-1k-1
			R47	MF, 1/4W, 1%, 511 Ω	110-511-1
			R48	MF, 1/4W, 1%, 5.11 Ω	110-5.11-1
			R49	MF, 1/4W, 1%, 5.11 Ω	110-5.11-1
			R50	MF, 1/4W, 1%, 2.74 k Ω	110-2.74k-1
			R51	MF, 1/4W, 1%, 10 k Ω	110-10k-1
			R52	MF, 1/4W, 1%, 750 k Ω	110-750k-1
			R53	MF, 1/4W, 1%, 14.7 k Ω	110-14.7k-1
			R54	MF, 1/4W, 1%, 10 k Ω	110-10k-1
			R55	MF, 1/4W, 1%, 750 k Ω	110-750k-1
			R56	MF, 1/4W, 1%, 14.7 k Ω	110-14.7k-1
			R57	MF, 1/4W, 1%, 5.11 Ω	110-5.11-1
			R58	Variable, 10-Turn, 500 Ω	157-500
			R59	MF, 1/4W, 1%, 2 k Ω	110-2k-1
			R60	MF, 1/4W, 1%, 10 k Ω	110-10k-1
			R61	MF, 1/4W, 1%, 750 k Ω	110-750k-1
			R62	MF, 1/4W, 1%, 14.7 k Ω	110-14.7k-1

<u>DIODES</u>		
REF. DES.	DESCRIPTION	WILTRON PART NO.
CR1	Silicon, 1N4446	10-1N4446
CR2	Silicon, 1N4446	10-1N4446
CR3	Silicon, 1N4446	10-1N4446
CR4	Silicon, SI2	10-SI2
CR5	Zener, 24V, 1W, 1N4749A	10-1N4749A
CR6	Silicon, 1N4446	10-1N4446
CR7	Silicon, 1N4446	10-1N4446
CR8	Zener, 6.8V, 1W, 1N4736A	10-1N4736A
CR9	Silicon, 1N4446	10-1N4446
CR10	Silicon, 1N4446	10-1N4446
CR11	Silicon, 1N4446	10-1N4446

<u>TRANSISTORS</u>		
REF. DES.	DESCRIPTION	WILTRON PART NO.
Q1	PNP, MPSA92	20-MPSA92
Q2	PNP, MPSA92	20-MPSA92
Q3	PNP, 2N2907A	20-2N2907A
Q4	NPN, 2N2222A	20-2N2222A
Q5	PNP, 2N2907A	20-2N2907A
Q6	NPN, 2N3694	20-2N3694
Q7	NPN, MPSU04	20-MPSU04
Q8	PNP, 2N2907A	20-2N2907A
Q9	NPN, 2N2222A	20-2N2222A

R63	MF, 1/4W, 1%, 6.49 kΩ	110-6.49k-1
R64	MF, 1/4W, 1%, 2 kΩ	110-2k-1
R65	Variable, 10-Turn, 500Ω	157-500
R66	Variable, 1-Turn, 500 kΩ	156-500k
R67	MF, 1/4W, 1%, 20 kΩ	110-20k-1
R68	MF, 1/4W, 1%, 10 kΩ	110-10k-1
R69	MF, 1/4W, 1%, 10 kΩ	110-10k-1
R70	MF, 1/4W, 1%, 15 kΩ	110-15k-1
R71	MF, 1/4W, 1%, 1.30 kΩ	110-1.30k-1
R72	MF, 1/4W, 1%, 8.87 kΩ	110-8.87k-1
R73	MF, 1/4W, 1%, 3.40 kΩ	110-3.40k-1
R74	MF, 1/4W, 1%, 5.11 kΩ	110-5.11k-1
R75	MF, 1/4W, 1%, 301Ω	110-301-1
R76	MF, 1/4W, 1%, 1.21 kΩ	110-1.21k-1
R77	MF, 1/4W, 1%, 17.8 kΩ	110-17.8k-1
R78	MF, 1/4W, 1%, 511Ω	110-511-1
R79	MF, 1/4W, 1%, 10 kΩ	110-10k-1
R80	MF, 1/4W, 1%, 10 kΩ	110-10k-1
R81	MF, 1/4W, 1%, 110 kΩ	110-110k-1
R82	MF, 1/4W, 1%, 2 kΩ	110-2k-1
R83	MF, 1/4W, 1%, 5.11 kΩ	110-5.11k-1
R84	MF, 1/4W, 1%, 1 MΩ	110-1M-1
R85	MF, 1/4W, 1%, 100 kΩ	110-100k-1
R86	MF, 1/4W, 1%, 5.11Ω	110-5.11-1
R87	MF, 1/4W, 1%, 5.11 kΩ	110-5.11k-1
R88	Variable, 1-Turn, 20Ω	156-20
R89	MF, 1/4W, 1%, 14.7 kΩ	110-14.7k-1
R91	MF, 1/4W, 1%, 20 kΩ	110-20k-1
R92	MF, 1/4W, 1%, 511Ω	110-511-1
R93	MF, 1/4W, 1%, 511Ω	110-511-1
R94	MF, 1/4W, 1%, 5.11 kΩ	110-5.11k-1
R95	MF, 1/4W, 1%, 5.11 kΩ	110-5.11k-1
R96	MF, 1/4W, 1%, 1 kΩ	110-1k-1

R97	MF, 1/4W, 1%, 15 kΩ	110-15k-1
R98	MF, 1/4W, 1%, 10 kΩ	110-10k-1
R99	MF, 1/4W, 1%, 750 kΩ	110-750k-1
R100	MF, 1/4W, 1%, 14.7 kΩ	110-14.7k-1

INTEGRATED CIRCUITS

REF. DES.	DESCRIPTION	WILTRON PART NO.
U1	Quad EX-OR Gate, 74LS86	54-125
U2	Quad Op Amp, TL074	54-132
U3	Quad Analog Switch, LF13201	54-20
U4	Op-Amp, OP05	54-87
U5	2k x 8 EPROM	Not Field-Replaceable
U7	Dual Analog Switch, DG200	50-DG200BA
U8	Dual Op-Amp, TL072	54-53
U9	Quad Volt Comparator, MC3302P	54-MC3302P
U10	Input NAND Gate, 74LS10	54-42

MISCELLANEOUS

REF. DES.	DESCRIPTION	WILTRON PART NO.
---	Ejector, P.C. Board	553-96
TP1	thru	
TP5	Pin, Test Point	706-44
K1	Relay, 2 Form C	690-28
---	Socket, I.C., 24-Pin	553-67

Table 6-8. A6 HET/YIG Driver, 2-8 GHz, 6621A/6637A/6638A/6647A/6648A (660-D-8007-3, -5, -99-91)

CAPACITORS			DIODES		
REF. DES.	DESCRIPTION	WILTRON PART NO.	REF. DES.	DESCRIPTION	WILTRON PART NO.
C1	Monolithic, .1 μF	230-37	CR1	Silicon, 1N4446	10-1N4446
C2	Monolithic, .1 μF	230-37	CR2	Silicon, 1N4446	10-1N4446
C3	Tantalum, 35V, 6.8 μF	250-41	CR3	Silicon, 1N4446	10-1N4446
C4	Monolithic, .1 μF	230-37	CR4	Silicon, SI2	10-SI2
C5	Tantalum, 35V, 6.8 μF	250-41	CR5	Zener, 24V, 1W, 1N4749A	10-1N4749A
C6	Monolithic, .1 μF	230-37	CR6	Silicon, 1N4446	10-1N4446
C7	Tantalum, 35V, 6.8 μF	250-41	CR7	Silicon, 1N4446	10-1N4446
C8	Monolithic, .1 μF	230-37	CR8	Zener, 6.8V, 1W, 1N4736A	10-1N4736A
C9	Ceramic, .01 μF	230-11	CR9	Silicon, 1N4446	10-1N4446
C10	Ceramic, .001 μF	230-30	CR10	Silicon, 1N4446	10-1N4446
C11	Tantalum, 1 μF, 35V	250-19	CR11	Silicon, 1N4446	10-1N4446
C12	Tantalum, 1 μF, 35V	250-19			
C13	Monolithic, 1 μF	230-41			
C14	Monolithic, .1 μF	230-37			
C15	Mica, 300 pF	220-300			
C16	Tantalum, 35V, 6.8 μF	250-41			
C18	Ceramic, .01 μF	230-11			
C19	Tantalum, 35V, 6.8 μF	250-41			
C21	Mica, 8.2 pF	221-8.2			
C22	Mica, 820 pF	220-820			
C23	Ceramic, .01 μF	230-11			
C24	Ceramic, .01 μF	230-11			
C25	Ceramic, .01 μF	230-11			

TRANSISTORS		
REF. DES.	DESCRIPTION	WILTRON PART NO.
Q1	PNP, MPSA92	20-MPSA92
Q2	PNP, MPSA92	20-MPSA92
Q3	PNP, 2N2907A	20-2N2907A
Q4	NPN, 2N2222A	20-2N2222A
Q5	PNP, 2N2907A	20-2N2907A
Q6	NPN, 2N3694	20-2N3694

Q7	NPN, MPSU04	20-MPSU04
Q8	PNP, 2N2907A	20-2N2907A
Q9	NPN, 2N2222A	20-2N2222A

RESISTORS

REF. DES.	DESCRIPTION	WILTRON PART NO.
R1	Variable, 1-Turn, 20 kΩ	156-20k
R2	MF, 1/4W, 1%, 61.9 kΩ	110-61.9k-1
R3	Variable, 10-Turn 1 kΩ	157-1k
R4	MF, 1/4W, 1%, 11 kΩ	110-11k-1
R5	MF, 1/4W, 1%, 5.11 kΩ	110-5.11k-1
R6	CC, 1/4W, 5%, 3.6 MΩ	101-3.6M-5
R7	Variable, 10-Turn, 1 kΩ	157-1k
R8	MF, 1/4W, 1%, 11 kΩ	110-11k-1
R9	Variable, 10-Turn, 200 kΩ	157-200k
R10	MF, 1/4W, 1%, 205 kΩ	110-205k-1
R11	MF, 1/4W, 1%, 100 kΩ	110-100k-1
R12	Variable, 10-Turn, 20 kΩ	157-20k
R13	MF, 1/4W, 1%, 75 kΩ	110-75k-1
R14 ¹	MF, 1/4W, 1%, 9.76 kΩ	110-9.76k-1
R14 ²	MF, 1/4W, 1%, 10.2k	110-10.2k-1
R14 ³	MF, 1/4W, 1%, 6.65k	110-6.65k-1
R15	WW, 5W, 5Ω	131-3
R16	MF, 1/4W, 1%, 100 kΩ	110-100k-1
R17 ¹	MF, 1/4W, 1%, 3.24 kΩ	110-3.24k-1
R17 ²	MF, 1/4W, 1%, 3.16k	110-3.16k-1
R17 ³	MF, 1/4W, 1%, 3.24k	110-3.24k-1
R18	MF, 1/4W, 1%, 10 kΩ	110-10k-1
R19	MF, 1/4W, 1%, 10 kΩ	110-10k-1
R20	MF, 1/4W, 1%, 10 kΩ	110-10k-1
R21	MF, 1/4W, 1%, 23.7 kΩ	110-23.7k-1
R22	MF, 1/4W, 1%, 1 kΩ	110-1k-1
R23	MF, 1/4W, 1%, 121Ω	110-121-1
R24	MF, 1/4W, 1%, 1 kΩ	110-1k-1
R25	MF, 1/4W, 1%, 7.5 kΩ	110-7.5k-1
R26	MF, 1/4W, 1%, 5.11Ω	110-5.11-1
R27	MF, 1/4W, 1%, 5.11 kΩ	110-5.11k-1
R28	MF, 1/4W, 1%, 18.7 kΩ	110-18.7k-1
R29 ¹	MF, 1/4W, 1%, 536 kΩ	110-536k-1
R29 ²	MF, 1/4W, 1%, 526Ω	110-526-1
R30	MF, 1/4W, 1%, 18.7 kΩ	110-18.7k-1
R31	MF, 1/4W, 1%, 18.7 kΩ	110-18.7k-1
R32	MF, 1/4W, 1%, 18.7 kΩ	110-18.7k-1
R33	MF, 1/4W, 1%, 18.7 kΩ	110-18.7k-1
R34	MF, 1/4W, 1%, 18.7 kΩ	110-18.7k-1
R35 ¹	MF, 1/4W, 1%, 536 kΩ	110-536k-1
R35 ²	MF, 1/4W, 1%, 526Ω	110-526-1
R36	Variable, 10-Turn, 2 kΩ	157-2k
R37	MF, 1/4W, 1%, 20 kΩ	110-20k-1
R38	Variable, 10-Turn, 50 kΩ	157-50k
R39	MF, 1/4W, 1%, 205 kΩ	110-205k-1
R40	MF, 1/4W, 1%, 75 kΩ	110-75k-1
R41	MF, 1/4W, 1%, 10 kΩ	110-10k-1
R42	MF, 1/4W, 1%, 15 kΩ	110-15k-1
R43	MF, 1/4W, 1%, 11 kΩ	110-11k-1
R44	MF, 1/4W, 1%, 3.24 kΩ	110-3.24k-1
R45	MF, 1/4W, 1%, 3.24 kΩ	110-3.24k-1
R46	MF, 1/4W, 1%, 1 kΩ	110-1k-1
R47	MF, 1/4W, 1%, 511Ω	110-511-1
R48	MF, 1/4W, 1%, 5.11Ω	110-5.11-1
R49	MF, 1/4W, 1%, 5.11Ω	110-5.11-1
R50	MF, 1/4W, 1%, 2.74 kΩ	110-2.74k-1
R51	MF, 1/4W, 1%, 10 kΩ	110-10k-1

¹ Used on 660-D-8007-3 assembly.

² Used on 660-D-8007-5 assembly.

³ Used on 660-D-8007-99-91 assembly.

R52	MF, 1/4W, 1%, 750 kΩ	110-750k-1
R53	MF, 1/4W, 1%, 14.7 kΩ	110-14.7k-1
R54	MF, 1/4W, 1%, 10 kΩ	110-10k-1
R55	MF, 1/4W, 1%, 750 kΩ	110-750k-1
R56	MF, 1/4W, 1%, 14.7 kΩ	110-14.7k-1
R57 ¹	MF, 1/4W, 1%, 2.74 kΩ	110-2.74k-1
R57 ²	MF, 1/4W, 1%, 3.16k	110-3.16k-1
R57 ³	MF, 1/4W, 1%, 2.74k	110-2.74k-1
R58	Variable, 10-Turn, 500Ω	157-500
R59	MF, 1/4W, 1%, 2 kΩ	110-2k-1
R60	MF, 1/4W, 1%, 10 kΩ	110-10k-1
R61	MF, 1/4W, 1%, 750 kΩ	110-750k-1
R62	MF, 1/4W, 1%, 14.7 kΩ	110-14.7k-1
R63 ¹	MF, 1/4W, 1%, 18.2 kΩ	110-18.2k-1
R63 ²	MF, 1/4W, 1%, 20k	110-20k-1
R64	MF, 1/4W, 1%, 2 kΩ	110-2k-1
R65	Variable, 10-Turn, 500Ω	157-500
R66	Variable, 1-Turn, 500 kΩ	156-500k
R67	MF, 1/4W, 1%, 20 kΩ	110-20k-1
R68	MF, 1/4W, 1%, 10 kΩ	110-10k-1
R69	MF, 1/4W, 1%, 10 kΩ	110-10k-1
R70	MF, 1/4W, 1%, 15 kΩ	110-15k-1
R71	MF, 1/4W, 1%, 1.30 kΩ	110-1.30k-1
R72	MF, 1/4W, 1%, 8.87 kΩ	110-8.87k-1
R73	MF, 1/4W, 1%, 3.40 kΩ	110-3.40k-1
R74	MF, 1/4W, 1%, 5.11 kΩ	110-5.11k-1
R75	MF, 1/4W, 1%, 301Ω	110-301-1
R76	MF, 1/4W, 1%, 1.21 kΩ	110-1.21k-1
R77	MF, 1/4W, 1%, 17.8 kΩ	110-17.8k-1
R78	MF, 1/4W, 1%, 511Ω	110-511-1
R79	MF, 1/4W, 1%, 10 kΩ	110-10k-1
R80	MF, 1/4W, 1%, 10 kΩ	110-10k-1
R81	MF, 1/4W, 1%, 205 kΩ	110-205k-1
R82	MF, 1/4W, 1%, 2 kΩ	110-2k-1
R83	MF, 1/4W, 1%, 5.11 kΩ	110-5.11k-1
R84	MF, 1/4W, 1%, 1 MΩ	110-1M-1
R85	Variable, 1-Turn, 100k	156-100k
R86	MF, 1/4W, 1%, 5.11Ω	110-5.11-1
R87	MF, 1/4W, 1%, 5.11 kΩ	110-5.11k-1
R88	Variable, 1-Turn, 20Ω	156-20
R89	MF, 1/4W, 1%, 15 kΩ	110-15k-1
R90	MF, 1/4W, 1%, 33.2 kΩ	110-33.2k-1
R90 ³	MF, 1/4W, 1%, 31.6k	110-31.6k-1
R91	MF, 1/4W, 1%, 33.2 kΩ	110-33.2k-1
R91 ³	MF, 1/4W, 1%, 20k	110-20k-1
R92	MF, 1/4W, 1%, 511Ω	110-511-1
R93	MF, 1/4W, 1%, 511Ω	110-511-1
R94	MF, 1/4W, 1%, 5.11 kΩ	110-5.11k-1
R95	MF, 1/4W, 1%, 5.11 kΩ	110-5.11k-1
R96	MF, 1/4W, 1%, 1 kΩ	110-1k-1
R97	MF, 1/4W, 1%, 15 kΩ	110-15k-1
R98	MF, 1/4W, 1%, 10 kΩ	110-10k-1
R99	MF, 1/4W, 1%, 750 kΩ	110-750k-1
R100	MF, 1/4W, 1%, 14.7 kΩ	110-14.7k-1

INTEGRATED CIRCUITS

REF. DES.	DESCRIPTION	WILTRON PART NO.
U1	Quad EX-OR Gate, 74LS86	54-125
U2	Quad Op Amp, TL074	54-132
U3	Quad Analog Switch, LF13201	54-20
U4	Op-Amp, OP05	54-87
U5	2k x 8 EPROM, 2716	Not Field-Replaceable
U7	Dual Analog Switch, DG200	50-DG200BA
U8	Dual Op-Amp, TL072	54-53
U9	Quad Volt Comparator, MC3302P	54-MC3302P
U10	Input NAND Gate, 74LS10	54-42

MISCELLANEOUS

REF. DES.	DESCRIPTION	WILTRON PART NO.
---	Ejector, P.C. Board	553-96

TP1 thru		
TP5	Pin, Test Point	706-44
K1	Relay, 2 Form C	690-28
---	Socket, I.C., 24-Pin	553-67

Table 6-9. A6 YIG Driver, 2-8 GHz, 6621A-40/6637A-40 (660-D-12868-3, -99-91)

REF. DES.	DESCRIPTION	WILTRON PART NO.
CAPACITORS		
C1	Monolithic, .1 μ F	230-37
C2	Monolithic, .1 μ F	230-37
C3	Tantalum, 35V, 6.8 μ F	250-41
C4	Monolithic, .1 μ F	230-37
C5	Tantalum, 35V, 6.8 μ F	250-41
C6	Monolithic, .1 μ F	230-37
C7	Tantalum, 35V, 6.8 μ F	250-41
C8	Monolithic, .1 μ F	230-37
C9	Ceramic, .01 μ F	230-11
C10	Ceramic, .001 μ F	230-30
C11	Tantalum, 1 μ F, 35V	250-19
C12	Tantalum, 1 μ F, 35V	250-19
C13	Monolithic, 1 μ F	230-41
C14	Monolithic, .1 μ F	230-37
C15	Mica, 300 pF	220-300
C16	Tantalum, 35V, 6.8 μ F	250-41
C17	Ceramic, .001 μ F	230-30
C18	Ceramic, .01 μ F	230-11
C19	Tantalum, 35V, 6.8 μ F	250-41
C21	Mica, 8.2 pF	221-8.2
C22	Mica, 820 pF	220-820
C23	Ceramic, .01 μ F	230-11
C24	Ceramic, .01 μ F	230-11
C25	Ceramic, .01 μ F	230-11
C26	Monolithic, .1 μ F	230-37

REF. DES.	DESCRIPTION	WILTRON PART NO.
DIODES		
CR1	Silicon, 1N4446	10-1N4446
CR2	Silicon, 1N4446	10-1N4446
CR3	Silicon, 1N4446	10-1N4446
CR4	Silicon, SI2	10-SI2
CR5	Zener, 24V, 1W, 1N4749A	10-1N4749A
CR6	Silicon, 1N4446	10-1N4446
CR7	Silicon, 1N4446	10-1N4446
CR8	Zener, 6.8V, 1W, 1N4736A	10-1N4736A
CR9	Silicon, 1N4446	10-1N4446
CR10	Silicon, 1N4446	10-1N4446
CR11	Silicon, 1N4446	10-1N4446

REF. DES.	DESCRIPTION	WILTRON PART NO.
TRANSISTORS		
Q1	PNP, MPSA92	20-MPSA92
Q2	PNP, MPSA92	20-MPSA92
Q3	PNP, 2N2907A	20-2N2907A
Q4	NPN, 2N2222A	20-2N2222A
Q5	PNP, 2N2907A	20-2N2907A
Q6	NPN, 2N3694	20-2N3694
Q7	NPN, MPSU04	20-MPSU04

Q8	PNP, 2N2907A	20-2N2907A
Q9	NPN, 2N2222A	20-2N2222A

REF. DES.	DESCRIPTION	WILTRON PART NO.
RESISTORS		
R1	Variable, 1-Turn, 20 k Ω	156-20k
R2	MF, 1/4W, 1%, 61.9 k Ω	110-61.9k-1
R3	Variable, 10-Turn, 1 k Ω	157-1k
R4	MF, 1/4W, 1%, 11 k Ω	110-11k-1
R5	MF, 1/4W, 1%, 50 k Ω	110-50k-1
R6	CC, 1/4W, 5%, 3.6 M Ω	101-3.6M-5
R7	Variable, 10-Turn, 1 k Ω	157-1k
R8	MF, 1/4W, 1%, 11 k Ω	110-11k-1
R9	Variable, 10-Turn, 200 k Ω	157-200k
R10	MF, 1/4W, 1%, 205 k Ω	110-205k-1
R11	MF, 1/4W, 1%, 100 k Ω	110-100k-1
R12	Variable, 10-Turn, 20 k Ω	157-20k
R13	MF, 1/4W, 1%, 75 k Ω	110-75k-1
R14	MF, 1/4W, 1%, 9.76 k Ω	110-9.76k-1
R14 ¹	MF, 1/4W, 1%, 6.65k	110-6.65k-1
R15	WW, 5W, 5 Ω	131-3
R16	MF, 1/4W, 1%, 100 k Ω	110-100k-1
R17	MF, 1/4W, 1%, 3.24 k Ω	110-3.24k-1
R18	MF, 1/4W, 1%, 10 k Ω	110-10k-1
R19	MF, 1/4W, 1%, 10 k Ω	110-10k-1
R20	MF, 1/4W, 1%, 10 k Ω	110-10k-1
R21	MF, 1/4W, 1%, 23.7 k Ω	110-23.7k-1
R22	MF, 1/4W, 1%, 1 k Ω	110-1k-1
R23	MF, 1/4W, 1%, 121 Ω	110-121-1
R24	MF, 1/4W, 1%, 1 k Ω	110-1k-1
R25	MF, 1/4W, 1%, 7.5 k Ω	110-7.5k-1
R26	MF, 1/4W, 1%, 5.11 Ω	110-5.11-1
R27	MF, 1/4W, 1%, 5.11 k Ω	110-5.11k-1
R28	MF, 1/4W, 1%, 18.7 k Ω	110-18.7k-1
R29	MF, 1/4W, 1%, 536 k Ω	110-536k-1
R30	MF, 1/4W, 1%, 18.7 k Ω	110-18.7k-1
R31	MF, 1/4W, 1%, 18.7 k Ω	110-18.7k-1
R32	MF, 1/4W, 1%, 18.7 k Ω	110-18.7k-1
R33	MF, 1/4W, 1%, 18.7 k Ω	110-18.7k-1
R34	MF, 1/4W, 1%, 18.7 k Ω	110-18.7k-1
R35	MF, 1/4W, 1%, 536 k Ω	110-536k-1
R36	Variable, 10-Turn, 2 k Ω	110-2k-1
R37	MF, 1/4W, 1%, 20 k Ω	110-20k-1
R38	Variable, 10-Turn, 50 k Ω	110-50k-1
R39	MF, 1/4W, 1%, 205 k Ω	110-205k-1
R40	MF, 1/4W, 1%, 75 k Ω	110-75k-1
R41	MF, 1/4W, 1%, 10 k Ω	110-10k-1
R42	MF, 1/4W, 1%, 9.53 k Ω	110-9.53k-1
R43	MF, 1/4W, 1%, 11 k Ω	110-11k-1
R44	MF, 1/4W, 1%, 3.24 k Ω	110-3.24k-1
R45	MF, 1/4W, 1%, 3.24 k Ω	110-3.24k-1
R46	MF, 1/4W, 1%, 1 k Ω	110-1k-1
R47	MF, 1/4W, 1%, 511 Ω	110-511-1
R48	MF, 1/4W, 1%, 5.11 Ω	110-5.11-1
R49	MF, 1/4W, 1%, 5.11 Ω	110-5.11-1
R50	MF, 1/4W, 1%, 2.74 k Ω	110-2.74k-1
R51	MF, 1/4W, 1%, 10 k Ω	110-10k-1

¹ Used on 660-D-12868-99-91

R52	MF, 1/4W, 1%, 750 kΩ	110-750k-1
R53	MF, 1/4W, 1%, 14.7 kΩ	110-14.7k-1
R54	MF, 1/4W, 1%, 10 kΩ	110-10k-1
R55	MF, 1/4W, 1%, 750 kΩ	110-750k-1
R56	MF, 1/4W, 1%, 14.7 kΩ	110-14.7k-1
R57	MF, 1/4W, 1%, 2.74 kΩ	110-2.74k-1
R58	Variable, 10-Turn, 500Ω	157-500
R59	MF, 1/4W, 1%, 2 kΩ	110-2k-1
R60	MF, 1/4W, 1%, 10 kΩ	110-10k-1
R61	MF, 1/4W, 1%, 750 kΩ	110-750k-1
R62	MF, 1/4W, 1%, 14.7 kΩ	110-14.7k-1
R63	MF, 1/4W, 1%, 18.2 kΩ	110-18.2k-1
R64	MF, 1/4W, 1%, 2 kΩ	110-2k-1
R65	Variable, 10-Turn, 500Ω	157-500
R66	Variable, 1-Turn, 500 kΩ	156-500k
R67	MF, 1/4W, 1%, 20 kΩ	110-20k-1
R68	MF, 1/4W, 1%, 10 kΩ	110-10k-1
R69	MF, 1/4W, 1%, 10 kΩ	110-10k-1
R70	MF, 1/4W, 1%, 15 kΩ	110-15k-1
R71	MF, 1/4W, 1%, 1.30 kΩ	110-1.30k-1
R72	MF, 1/4W, 1%, 8.87 kΩ	110-8.87k-1
R73	MF, 1/4W, 1%, 3.40 kΩ	110-3.40k-1
R74	MF, 1/4W, 1%, 5.11 kΩ	110-5.11k-1
R75	MF, 1/4W, 1%, 301Ω	110-301-1
R76	MF, 1/4W, 1%, 1.21 kΩ	110-1.21k-1
R77	MF, 1/4W, 1%, 17.8 kΩ	110-17.8k-1
R78	MF, 1/4W, 1%, 511Ω	110-511-1
R79	MF, 1/4W, 1%, 10 kΩ	110-10k-1
R80	MF, 1/4W, 1%, 10 kΩ	110-10k-1
R81	MF, 1/4W, 1%, 205 kΩ	110-205k-1
R82	MF, 1/4W, 1%, 2 kΩ	110-2k-1
R83	MF, 1/4W, 1%, 5.11 kΩ	110-5.11k-1
R84	MF, 1/4W, 1%, 1 MΩ	110-1M-1
R85	Variable, 1-Turn, 100 kΩ	156-100k
R86	MF, 1/4W, 1%, 5.11Ω	110-5.11-1
R87	MF, 1/4W, 1%, 5.11 kΩ	110-5.11k-1

R88	Variable, 1-Turn 20Ω	156-20
R89	MF, 1/4W, 1%, 15k	110-15k-1
R90	MF, 1/4W, 1%, 33.2 kΩ	110-33.2k-1
R90 ¹	MF, 1/4W, 1%, 31.6 kΩ	110-31.6k-1
R91	MF, 1/4W, 1%, 33.2 kΩ	110-33.2k-1
R91 ¹	MF, 1/4W, 1%, 31.6 kΩ	110-31.6k-1
R92	MF, 1/4W, 1%, 511Ω	110-511-1
R93	MF, 1/4W, 1%, 511Ω	110-511-1
R94	Variable, 10-Turn, 20 kΩ	157-20k
R95	MF, 1/4W, 1%, 5.11Ω	110-5.11-1
R96	MF, 1/4W, 1%, 10 kΩ	110-10k-1
R97	MF, 1/4W, 1%, 750 kΩ	110-750k-1
R98	MF, 1/4W, 1%, 14.7 kΩ	110-14.7k-1

INTEGRATED CIRCUITS

REF. DES.	DESCRIPTION	WILTRON PART NO.
U4	Op-Amp, OP05	54-87
U5	2k x 8 EPROM	Not Field-Replaceable
U8	Dual Op-Amp, TL072	54-53
U10	Input NAND Gate, 74LS10	54-42

MISCELLANEOUS

REF. DES.	DESCRIPTION	WILTRON PART NO.
---	Ejector, P.C. Board	553-96
TP1 thru TP5	Pin, Test Point	706-44
K1	Relay, 2 Form C	690-28
---	Socket, I.C., 24-Pin	553-67

Table 6-10. A6 YIG Driver, 18-26.5 GHz, 6642A (660-D-8190-99-98)

CAPACITORS			DIODES		
REF. DES.	DESCRIPTION	WILTRON PART NO.	REF. DES.	DESCRIPTION	WILTRON PART NO.
C1	Tantalum, 4.7 μF	250-39	CR1	Silicon, 1N4446	10-1N4446
C2	Tantalum, 4.7 μF	250-39	CR2	Silicon, 1N4446	10-1N4446
C3	Tantalum, 4.7 μF	250-39	CR3	Silicon, Si2	10-SI2
C4	Disc Ceramic, .01 μF	230-11	CR4	Zener, 24V, 1W, 1N4749A	10-1N4749A
C5	Disc Ceramic, .001 μF	230-30	CR5	Silicon, Si2	10-SI2
C6	Tantalum, 1 μF	250-19	CR6	Silicon, 1N4446	10-1N4446
C7	Tantalum, 1 μF	250-19	CR7	Silicon, 1N4446	10-1N4446
C8	Monolithic, 1.0 μF	230-41	CR8	Silicon, 1N4446	10-1N4446
C9	Mica, 300 pF	220-300	CR9	Zener, 10V, 0.4W, 1N758A	10-1N758A
C10	Monolithic, .1 μF	230-37	CR10	Silicon, 1N4446	10-1N4446
C11	Tantalum, 6.8 μF	250-41			
C12	Mica, 5 pF	220-5			
C13	Monolithic, .1 μF	230-37			
C14	Disc Ceramic, .01 μF	230-11			
C16	Monolithic, .1 μF	230-37			
C17	Disc Ceramic, .01 μF	230-11			
C18	Disc Ceramic, .01 μF	230-11			
C19	Disc Ceramic, .01 μF	230-11			
C20	Mica, 820 pF	220-820			
C21	Mica, 39 pF	220-39			
			TRANSISTORS		
REF. DES.	DESCRIPTION	WILTRON PART NO.	REF. DES.	DESCRIPTION	WILTRON PART NO.
Q1	PNP, MPSA92	20-MPSA92	Q1	PNP, MPSA92	20-MPSA92
Q2	PNP, MPSA92	20-MPSA92	Q2	PNP, MPSA92	20-MPSA92
Q3	NPN, 2N4249	20-2N4249	Q3	NPN, 2N4249	20-2N4249
Q4	NPN, MPSU55	20-30	Q4	NPN, MPSU55	20-30

¹Used on 660-D-12868-99-91

Q5	NPN, 2N2222A	20-2N2222A
Q6	PNP, 2N2907A	20-2N2907A
Q7	NPN, 2N2222A	20-2N2222A
Q8	NPN, 2N2222A	20-2N2222A

RESISTORS

REF. DES.	DESCRIPTION	WILTRON PART NO.
R1	CC, 1/4W, 5%, 3.3 MΩ	101-3.3M-5
R2	Variable, 10-Turn, 50 kΩ	157-50k
R3	CC, 1/4W, 5%, 3.6 MΩ	101-3.6M-5
R4	MF, 1/8W, 1%, 61.9 kΩ	110-61.9k-1
R5	Variable, 10-Turn, 1 kΩ	157-1k
R6	MF, 1/8W, 1%, 10 kΩ	110-10k-1
R7	Variable, 10-Turn, 1 kΩ	157-1k
R8	MF, 1/8W, 1%, 10 kΩ	110-10k-1
R9	Variable, 10-Turn, 200 kΩ	157-200k
R10	MF, 1/8W, 1%, 301 kΩ	110-301k-1
R11	MF, 1/8W, 1%, 6.19 kΩ	110-6.19k-1
R12	MF, 1/8W, 1%, 20 kΩ	110-20k-1
R13	Variable, 1-Turn, 20 kΩ	156-20k
R14	MF, 1/8W, 1%, 2.61 kΩ	110-2.61k-1
R15	MF, 1/8W, 1%, 10 kΩ	110-10k-1
R16	MF, 1/8W, 1%, 10 kΩ	110-10k-1
R17	MF, 1/8W, 1%, 10 kΩ	110-10k-1
R18	MF, 1/8W, 1%, 23.7 kΩ	110-23.7k-1
R19	MF, 1/8W, 1%, 1 kΩ	110-1k-1
R20	MF, 1/8W, 1%, 121Ω	110-121-1
R21	MF, 1/8W, 1%, 1 kΩ	110-1k-1
R22	MF, 1/8W, 1%, 7.5 kΩ	110-7.5k-1
R23	MF, 1/8W, 1%, 511Ω	110-511-1
R24	MF, 1/8W, 1%, 5.11 kΩ	110-5.11k-1
R25	WW, 5W, 5Ω	131-3
R26	MF, 1/8W, 1%, 15.4 kΩ	110-15.4k-1
R27	MF, 1/8W, 1%, 649Ω	110-649-1
R28	MF, 1/8W, 1%, 6.19 kΩ	110-6.19k-1
R29	MF, 1/8W, 1%, 1.37 kΩ	110-1.37k-1
R30	MF, 1/8W, 1%, 3.83 kΩ	110-3.83k-1
R31	MF, 1/8W, 1%, 1 kΩ	110-1k-1
R32	MF, 1/8W, 1%, 1.21 kΩ	110-1.21k-1
R33	MF, 1/8W, 1%, 17.8 kΩ	110-17.8k-1
R34	Variable, 1-Turn, 500 kΩ	156-500k
R35	MF, 1/8W, 1%, 49.9 kΩ	110-49.9k-1
R36	MF, 1/8W, 1%, 5.11 kΩ	110-5.11k-1
R37	MF, 1/8W, 1%, 5.11 kΩ	110-5.11k-1
R38	MF, 1/8W, 1%, 18.7 kΩ	110-18.7k-1
R39	MF, 1/8W, 1%, 18.7 kΩ	110-18.7k-1
R40	MF, 1/8W, 1%, 10 kΩ	110-10k-1
R41	MF, 1/8W, 1%, 133 kΩ	110-133k-1
R42	Variable, 10-Turn, 50 kΩ	157-50k
R43	MF, 1/8W, 1%, 18.7 kΩ	110-18.7k-1
R44	MF, 1/8W, 1%, 18.7 kΩ	110-18.7k-1
R45	MF, 1/8W, 1%, 10 kΩ	110-10k-1
R46	MF, 1/8W, 1%, 14.7 kΩ	110-14.7k-1
R47	Variable, 10-Turn, 1 kΩ	157-1k
R48	MF, 1/8W, 1%, 11 kΩ	110-11k-1
R49	MF, 1/8W, 1%, 10 kΩ	110-10k-1
R50	MF, 1/8W, 1%, 511Ω	110-511-1
R51	MF, 1/8W, 1%, 4.99 kΩ	110-4.99k-1
R52	MF, 1/8W, 1%, 3.83 kΩ	110-3.83k-1

R53	MF, 1/8W, 1%, 1 kΩ	110-1k-1
R54	MF, 1/8W, 1%, 511Ω	110-511-1
R55	CC, 1/2W, 5%, .5Ω	102-.5-5
R56	CC, 1/2W, 5%, .5Ω	102-.5-5
R57	MF, 1/8W, 1%, 5.11Ω	110-5.11-1
R58	MF, 1/8W, 1%, 5.11Ω	110-5.11-1
R60	MF, 1/8W, 1%, 2.15 kΩ	110-2.15k-1
R61	MF, 1/8W, 1%, 511Ω	110-511-1
R62	MF, 1/8W, 1%, 511Ω	110-511-1
R63	MF, 1/8W, 1%, 10 kΩ	110-10k-1
R64	MF, 1/8W, 1%, 10 kΩ	110-10k-1
R65	MF, 1/8W, 1%, 750 kΩ	110-750k-1
R66	MF, 1/8W, 1%, 14.7 kΩ	110-14.7k-1
R67	MF, 1/8W, 1%, 5.11Ω	110-5.11-1
R68	Variable, 10-Turn, 500Ω	157-500
R69	MF, 1/8W, 1%, 2 kΩ	110-2k-1
R70	MF, 1/8W, 1%, 10 kΩ	110-10k-1
R71	MF, 1/8W, 1%, 750 kΩ	110-750k-1
R72	MF, 1/8W, 1%, 14.7 kΩ	110-14.7k-1
R73	MF, 1/8W, 1%, 10 kΩ	110-10k-1
R74	MF, 1/8W, 1%, 10 kΩ	110-10k-1
R75	MF, 1/8W, 1%, 205 kΩ	110-205k-1
R76	MF, 1/8W, 1%, 511Ω	110-511-1
R77	Variable, 1-Turn, 20Ω	156-20
R78	MF, 1/8W, 1%, 2 kΩ	110-2k-1
R79	MF, 1/8W, 1%, 14.7 kΩ	110-14.7k-1
R80	MF, 1/8W, 1%, 23.7 kΩ	110-23.7k-1
R81	MF, 1/8W, 1%, 23.7 kΩ	110-23.7k-1
R82	MF, 1/8W, 1%, 20 kΩ	110-20k-1
R83	MF, 1/8W, 1%, 20 kΩ	110-20k-1
R84	MF, 1/8W, 1%, 5.11 kΩ	110-5.11k-1
R85	MF, 1/8W, 1%, 5.11 kΩ	110-5.11k-1
R86	MF, 1/8W, 1%, 511Ω	110-511-1

INTEGRATED CIRCUITS

REF. DES.	DESCRIPTION	WILTRON PART NO.
U1	Quad Analog Switch, LF13201	54-20
U2	NAND Gate, 74LS10	54-42
U3	Op Amp, OP05	54-87
U4	Dual Op Amp, TL072	54-53
U5	256 x 4 PROM,	Not Field-Replaceable
U7	Quad Op Amp, TL074	54-132
U8	Quad Ex. OR Gate 74LS86	54-125
U9	Dual Volt. Comp., LM393	54-158

MISCELLANEOUS

REF. DES.	DESCRIPTION	WILTRON PART NO.
---	Ejector, P.C. Board	553-96
TP1 thru TP4	Pin, Test Point	706-44
K1	Relay, 2 Form C	690-28
---	Socket, I.C., 24-Pin	553-67

Table 6-11. A6 HET/YIG Driver, 2-8 GHz, 6653A/6659A (660-D-8007-7)

<u>CAPACITORS</u>			<u>RESISTORS</u>		
REF. DES.	DESCRIPTION	WILTRON PART NO.	REF. DES.	DESCRIPTION	WILTRON PART NO.
C1	Monolithic, .1 μ F	230-37	R1	Variable, 1-Turn, 20 k Ω	156-20K
C2	Monolithic, .1 μ F	230-37	R2	MF, 1/4W, 1%, 61.9 k Ω	110-61.9k-1
C3	Tantalum, 35V, 6.8 μ F	250-41	R3	Variable, 10-Turn, 1 k Ω	157-1k
C4	Monolithic, .1 μ F	230-37	R4	MF, 1/4W, 1%, 11 k Ω	110-11k-1
C5	Tantalum, 35V, 6.8 μ F	250-41	R5	Variable, 10-Turn, 50 k Ω	157-50k
C6	Monolithic, .1 μ F	230-37	R6	CC, 1/4W, 5%, 3.6 M Ω	101-3.6M-5
C7	Tantalum, 35V, 6.8 μ F	250-41	R7	Variable, 10-Turn, 1 k Ω	157-1k
C8	Monolithic, .1 μ F	230-37	R8	MF, 1/4W, 1%, 11 k Ω	110-11k-1
C9	Ceramic, .01 μ F	230-11	R9	Variable, 10-Turn, 200 k Ω	157-200k
C10	Ceramic, .001 μ F	230-30	R10	MF, 1/4W, 1%, 205 k Ω	110-205k-1
C11	Tantalum, 1 μ F, 35V	250-19	R11	MF, 1/4W, 1%, 100 k Ω	110-100k-1
C12	Tantalum, 1 μ F, 35V	250-19	R12	Variable, 10-Turn, 20 k Ω	157-20k
C13	Monolithic, 1 μ F	230-41	R13	MF, 1/4W, 1%, 110 k Ω	110-110k-1
C14	Monolithic, .1 μ F	230-37	R14	MF, 1/4W, 1%, 14.0 k Ω	110-14.0k-1
C15	Mica, 300 pF	220-300	R15	WW, 5W, 5 Ω	131-3
C16	Tantalum, 35V, 6.8 μ F	250-41	R16	MF, 1/4W, 1%, 100 k Ω	110-100k-1
C17	Ceramic, .001 μ F	230-30	R17	MF, 1/4W, 1%, 3.16 k Ω	110-3.16k-1
C18	Ceramic, .01 μ F	230-11	R18	MF, 1/4W, 1%, 10 k Ω	110-10k-1
C19	Tantalum, 35V, 6.8 μ F	250-41	R19	MF, 1/4W, 1%, 10 k Ω	110-10k-1
C21	Mica, 8.2 pF	221-8.2	R20	MF, 1/4W, 1%, 10 k Ω	110-10k-1
C22	Mica, 820 pF	220-820	R21	MF, 1/4W, 1%, 23.7 k Ω	110-23.7k-1
C23	Ceramic, .01 μ F	230-11	R22	MF, 1/4W, 1%, 1 k Ω	110-1k-1
C24	Ceramic, .01 μ F	230-11	R23	MF, 1/4W, 1%, 121 Ω	110-121-1
C25	Ceramic, .01 μ F	230-11	R24	MF, 1/4W, 1%, 1 k Ω	110-1k-1
C26	Monolithic, .1 μ F	230-37	R25	MF, 1/4W, 1%, 7.5 k Ω	110-7.5k-1
			R26	MF, 1/4W, 1%, 5.11 Ω	110-5.11-1
			R27	MF, 1/4W, 1%, 5.11 k Ω	110-5.11k-1
			R28	MF, 1/4W, 1%, 18.7 k Ω	110-18.7k-1
			R29	MF, 1/4W, 1%, 536 k Ω	110-536k-1
			R30	MF, 1/4W, 1%, 18.7 k Ω	110-18.7k-1
			R31	MF, 1/4W, 1%, 18.7 k Ω	110-18.7k-1
			R32	MF, 1/4W, 1%, 18.7 k Ω	110-18.7k-1
			R33	MF, 1/4W, 1%, 18.7 k Ω	110-18.7k-1
			R34	MF, 1/4W, 1%, 18.7 k Ω	110-18.7k-1
			R35	MF, 1/4W, 1%, 536 k Ω	110-536k-1
			R36	Variable, 10-Turn, 2 k Ω	157-2k
			R37	MF, 1/4W, 1%, 20 k Ω	110-20k-1
			R38	Variable, 10-Turn, 50 k Ω	157-50k
			R39	MF, 1/4W, 1%, 205 k Ω	110-205k-1
			R40	MF, 1/4W, 1%, 75 k Ω	110-75k-1
			R41	MF, 1/4W, 1%, 10 k Ω	110-10k-1
			R42	MF, 1/4W, 1%, 15 k Ω	110-15k-1
			R43	MF, 1/4W, 1%, 11 k Ω	110-11k-1
			R44	MF, 1/4W, 1%, 3.24 k Ω	110-3.24k-1
			R45	MF, 1/4W, 1%, 3.24 k Ω	110-3.24k-1
			R46	MF, 1/4W, 1%, 1 k Ω	110-1k-1
			R47	MF, 1/4W, 1%, 511 Ω	110-511-1
			R48	MF, 1/4W, 1%, 5.11 Ω	110-5.11-1
			R49	MF, 1/4W, 1%, 5.11 Ω	110-5.11-1
			R50	MF, 1/4W, 1%, 2.74 k Ω	110-2.74k-1
			R51	MF, 1/4W, 1%, 10 k Ω	110-10k-1
			R52	MF, 1/4W, 1%, 750 k Ω	110-750k-1
			R53	MF, 1/4W, 1%, 14.7 k Ω	110-14.7k-1
			R54	MF, 1/4W, 1%, 10 k Ω	110-10k-1
			R55	MF, 1/4W, 1%, 750 k Ω	110-750k-1
			R56	MF, 1/4W, 1%, 14.7 k Ω	110-14.7k-1
			R57	MF, 1/4W, 1%, 5.11 k Ω	110-5.11k-1
			R58	Variable, 10-Turn, 500 Ω	157-500
			R59	MF, 1/4W, 1%, 2 k Ω	110-2k-1
			R60	MF, 1/4W, 1%, 10 k Ω	110-10k-1
			R61	MF, 1/4W, 1%, 750 k Ω	110-750k-1
			R62	MF, 1/4W, 1%, 14.7 k Ω	110-14.7k-1

<u>DIODES</u>		
REF. DES.	DESCRIPTION	WILTRON PART NO.
CR1	Silicon, 1N4446	10-1N4446
CR2	Silicon, 1N4446	10-1N4446
CR3	Silicon, 1N4446	10-1N4446
CR4	Silicon, SI2	10-SI2
CR5	Zener, 24V, 1W, 1N4749A	10-1N4749A
CR6	Silicon, 1N4446	10-1N4446
CR7	Silicon, 1N4446	10-1N4446
CR8	Zener, 6.8V, 1W, 1N4736A	10-1N4736A
CR9	Silicon, 1N4446	10-1N4446
CR10	Silicon, 1N4446	10-1N4446
CR11	Silicon, 1N4446	10-1N4446

<u>TRANSISTORS</u>		
REF. DES.	DESCRIPTION	WILTRON PART NO.
Q1	PNP, MPSA92	20-MPSA92
Q2	PNP, MPSA92	20-MPSA92
Q3	PNP, 2N2907A	20-2N2907A
Q4	NPN, 2N2222A	20-2N2222A
Q5	PNP, 2N2907A	20-2N2907A
Q6	NPN, 2N3694	20-2N3694
Q7	NPN, MPSU04	20-MPSU04
Q8	PNP, 2N2907A	20-2N2907A
Q9	NPN, 2N2222A	20-2N2222A

R63	MF, 1/4W, 1%, 27.4 kΩ	110-27.4k-1
R64	MF, 1/4W, 1%, 2 kΩ	110-2k-1
R65	Variable, 10-Turn, 500Ω	157-500
R66	Variable, 1-Turn, 500 kΩ	156-500k
R67	MF, 1/4W, 1%, 20 kΩ	110-20k-1
R68	MF, 1/4W, 1%, 10 kΩ	110-10k-1
R69	MF, 1/4W, 1%, 10 kΩ	110-10k-1
R70	MF, 1/4W, 1%, 15 kΩ	110-15k-1
R71	MF, 1/4W, 1%, 1.30 kΩ	110-1.30k-1
R72	MF, 1/4W, 1%, 8.87 kΩ	110-8.87k-1
R73	MF, 1/4W, 1%, 3.40 kΩ	110-3.40k-1
R74	MF, 1/4W, 1%, 5.11 kΩ	110-5.11k-1
R75	MF, 1/4W, 1%, 301Ω	110-301-1
R76	MF, 1/4W, 1%, 1.21 kΩ	110-1.21k-1
R77	MF, 1/4W, 1%, 17.8 kΩ	110-17.8k-1
R78	MF, 1/4W, 1%, 511Ω	110-511-1
R79	MF, 1/4W, 1%, 10 kΩ	110-10k-1
R80	MF, 1/4W, 1%, 10 kΩ	110-10k-1
R81	MF, 1/4W, 1%, 205 kΩ	110-205k-1
R82	MF, 1/4W, 1%, 2 kΩ	110-2k-1
R83	MF, 1/4W, 1%, 5.11 kΩ	110-5.11k-1
R84	MF, 1/4W, 1%, 1M	110-1M-1
R85	MF, 1/4W, 1%, 100 kΩ	110-100k-1
R86	MF, 1/4W, 1%, 5.11Ω	110-5.11-1
R87	MF, 1/4W, 1%, 5.11 kΩ	110-5.11k-1
R88	Variable, 1-Turn, 20Ω	156-20
R89	MF, 1/4W, 1%, 15 kΩ	110-15k-1
R90	MF, 1/4W, 1%, 31.6 kΩ	110-31.6k-1
R91	MF, 1/4W, 1%, 20 kΩ	110-20k-1
R92	MF, 1/4W, 1%, 511Ω	110-511-1
R93	MF, 1/4W, 1%, 511Ω	110-511-1
R94	MF, 1/4W, 1%, 5.11 kΩ	110-5.11k-1
R95	MF, 1/4W, 1%, 5.11 kΩ	110-5.11k-1

R96	MF, 1/4W, 1%, 1 kΩ	110-1k-1
R97	MF, 1/4W, 1%, 15 kΩ	110-15k-1
R98	MF, 1/4W, 1%, 10 kΩ	110-10k-1
R99	MF, 1/4W, 1%, 750 kΩ	110-750k-1
R100	MF, 1/4W, 1%, 14.7 kΩ	110-14.7k-1

INTEGRATED CIRCUITS

REF. DES.	DESCRIPTION	WILTRON PART NO.
U1	Quad EX-OR Gate, 74LS86	54-125
U2	Quad Op Amp, TL074	54-132
U3	Quad Analog Switch, LF13201	54-20
U4	Op-Amp, OP05	54-87
U5	2k x 8 EPROM	Not Field-Replaceable
U7	Dual Analog Switch, DG200	50-DG200BA
U8	Dual Op-Amp, TL072	54-53
U9	Quad Volt Comparator, MC3302P	54-MC3302P
U10	Input NAND Gate, 74LS10	54-42

MISCELLANEOUS

REF. DES.	DESCRIPTION	WILTRON PART NO.
---	Ejector, P.C. Board	553-96
TP1	thru	
TP5	Pin, Test Point	706-44
K1	Relay, 2 Form C	690-28
---	Socket, I.C., 24-Pin	553-67

Table 6-12. A6/A7/A8 YIG Driver, 8-12.4 GHz, 6621A/6629A/6637A/6638A/6647A/6648A (660-D-8009-4, -6, -7, -8, -99-90, -99-92)

CAPACITORS			TRANSISTORS		
REF. DES.	DESCRIPTION	WILTRON PART NO.	REF. DES.	DESCRIPTION	WILTRON PART NO.
C1	Tantalum, 4.7 μF	250-39	Q1	PNP, MPSA92	20-MPSA92
C2	Tantalum, 4.7 μF	250-39	Q2	PNP, MPSA92	20-MPSA92
C3	Tantalum, 4.7 μF	250-39	Q3	NPN, 2N3694	20-2N3694
C4	Disc Ceramic, .01 μF	230-11	Q4	NPN, 2N2222A	20-2N2222A
C5	Disc Ceramic, .001 μF	230-30	Q5	NPN, 2N2222A	20-2N2222A
C6	Tantalum, 1 μF, 35V	250-19	Q6	PNP, 2N2907A	20-2N2907A
C7	Tantalum, 1 μF, 35V	250-19	Q7	NPN, 2N2222A	20-2N2222A
C8	Monolithic, 1.0 μF	230-41			
C9	Mica, 300 pF	220-300			
C10	Monolithic, .1 μF	230-37			
C11	Tantalum, 6.8 μF	250-41A			
C12	Mica, 5 pF	220-5			
C13	Monolithic, .1 μF	230-37			
C14	Disc Ceramic, .01 μF	230-11			
C16	Monolithic, .1 μF	230-37			
C17	Disc Ceramic, .01 μF	230-11			
C18	Disc Ceramic, .01 μF	230-11			
C19	Disc Ceramic, .01 μF	230-11			
C20	Mica, 820 pF	220-820			
DIODES			RESISTORS		
REF. DES.	DESCRIPTION	WILTRON PART NO.	REF. DES.	DESCRIPTION	WILTRON PART NO.
CR1	Silicon, 1N4446	10-1N4446	R1	CC, 1/4W, 5%, 3.3 MΩ	101-3.3M-5
			R2	Variable, 15-Turn, 50 kΩ	157-50k

R3	CC, 1/4W, 5%, 3.6 MΩ	101-3.6M-5
R4	MF, 1/4W, 1%, 61.9 kΩ	110-61.9k-1
R5	Variable, 15-Turn, 1 kΩ	157-1k
R7	Variable, 15-Turn, 1 kΩ	157-1k
R9	Variable, 15-Turn, 200 kΩ	157-200k
R10	MF, 1/4W, 1%, 205 kΩ	110-205k-1
R10 ⁵	MF, 1/4W, 1%, 6.65 kΩ	110-6.65k-1
R10 ⁶	MF, 1/4W, 1%, 10 kΩ	110-10k-1
R11 ¹	MF, 1/4W, 1%, 10.5 kΩ	110-10.5k-1
R11 ²	MF, 1/4W, 1%, 11 kΩ	110-11k-1
R11 ³	MF, 1/4W, 1%, 10 kΩ	110-10k-1
R11 ⁴	MF, 1/4W, 1%, 11 kΩ	110-11k-1
R12	MF, 1/4W, 1%, 20 kΩ	110-20k-1
R13	Variable, 1-Turn, 20 kΩ	156-20k
R14	MF, 1/4W, 1%, 2.74 kΩ	110-2.74k-1
R14 ⁵	MF, 1/4W, 1%, 2.67 kΩ	110-2.67k-1
R14 ⁶	MF, 1/4W, 1%, 4.22 kΩ	110-4.22k-1
R15	MF, 1/4W, 1%, 10 kΩ	110-10k-1
R16	MF, 1/4W, 1%, 4.99 kΩ	110-4.99k-1
R17	MF, 1/4W, 1%, 10 kΩ	110-10k-1
R18	MF, 1/4W, 1%, 23.7 kΩ	110-23.7k-1
R19	MF, 1/4W, 1%, 1 kΩ	110-1k-1
R20	MF, 1/4W, 1%, 121Ω	110-121-1
R21	MF, 1/4W, 1%, 1 kΩ	110-1k-1
R22	MF, 1/4W, 1%, 7.5 kΩ	110-7.5k-1
R23	MF, 1/4W, 1%, 511Ω	110-511-1
R24	MF, 1/4W, 1%, 5.11 kΩ	110-5.11k-1
R25	WW, 5W, 5Ω	131-3
R26	MF, 1/4W, 1%, 10 kΩ	110-10k-1
R27	MF, 1/4W, 1%, 750Ω	110-750-1
R28	MF, 1/4W, 1%, 5.49 kΩ	110-5.49k-1
R29	MF, 1/4W, 1%, 1.78 kΩ	110-1.78k-1
R30	MF, 1/4W, 1%, 2.15 kΩ	110-2.15k-1
R31	MF, 1/4W, 1%, 1 kΩ	110-1k-1
R32	MF, 1/4W, 1%, 1.21 kΩ	110-1.21k-1
R33	MF, 1/4W, 1%, 17.8 kΩ	110-17.8k-1
R34	Variable, 1-Turn, 200 kΩ	156-200k
R35	MF, 1/4W, 1%, 1 kΩ	110-1k-1
R38	MF, 1/4W, 1%, 18.7 kΩ	110-18.7k-1
R39	MF, 1/4W, 1%, 18.7 kΩ	110-18.7k-1
R42	Variable, 15-Turn, 50 kΩ	157-50k
R43	MF, 1/4W, 1%, 18.7 kΩ	110-18.7k-1
R44	MF, 1/4W, 1%, 18.7 kΩ	110-18.7k-1
R45	MF, 1/4W, 1%, 10 kΩ	110-10k-1
R46	MF, 1/4W, 1%, 9.53 kΩ	110-9.53k-1
R47	Variable, 15-Turn, 1 kΩ	157-1k
R48	MF, 1/4W, 1%, 11 kΩ	110-11k-1
R49	MF, 1/4W, 1%, 10 kΩ	110-10k-1
R50	MF, 1/4W, 1%, 511Ω	110-511-1
R51	MF, 1/4W, 1%, 4.99 kΩ	110-4.99k-1
R52	MF, 1/4W, 1%, 3.83 kΩ	110-3.83k-1
R53	MF, 1/4W, 1%, 1 kΩ	110-1k-1
R54	MF, 1/4W, 1%, 511Ω	110-511-1
R55	MF, 1/4W, 1%, 6.19Ω	110-6.19-1
R55 ⁵	MF, 1/4W, 1%, 6.49Ω	110-6.49-1
R55 ⁶	MF, 1/4W, 1%, 6.49Ω	110-6.49-1
R56	MF, 1/4W, 1%, 6.19Ω	110-6.19-1
R56 ⁵	MF, 1/4W, 1%, 6.49Ω	110-6.49-1
R57	MF, 1/4W, 1%, 6.19Ω	110-6.19-1
R57 ⁵	MF, 1/4W, 1%, 6.49Ω	110-6.49-1
R57 ⁶	MF, 1/4W, 1%, 6.49Ω	110-6.49-1
R58	MF, 1/4W, 1%, 6.19Ω	110-6.19-1
R58 ⁵	MF, 1/4W, 1%, 6.49Ω	110-6.49-1
R58 ⁶	MF, 1/4W, 1%, 6.49Ω	110-6.49-1

¹Used on 660-D-8009-4 assembly.

²Used on 660-D-8009-6 assembly.

³Used on 660-D-8009-7 assembly.

⁴Used on 660-D-8009-8 assembly.

⁵Used on 660-D-8009-99-90 assembly.

⁶Used on 660-D-8009-99-91 assembly.

R59	MF, 1/4W, 1%, 6.19Ω	110-6.19-1
R59 ⁵	MF, 1/4W, 1%, 6.49Ω	110-6.49-1
R59 ⁶	MF, 1/4W, 1%, 6.49Ω	110-6.49-1
R60	MF, 1/4W, 1%, 2.15 kΩ	110-2.15k-1
R61 ¹	MF, 1/4W, 1%, 33.2 kΩ	110-33.2k-1
R61 ²	MF, 1/4W, 1%, 33.2 kΩ	110-33.2k-1
R61 ³	MF, 1/4W, 1%, 38.3 kΩ	110-38.3k-1
R61 ⁴	MF, 1/4W, 1%, 38.3 kΩ	110-38.3k-1
R62 ¹	MF, 1/4W, 1%, 33.2 kΩ	110-33.2k-1
R62 ²	MF, 1/4W, 1%, 33.2 kΩ	110-33.2k-1
R62 ³	MF, 1/4W, 1%, 38.3 kΩ	110-38.3k-1
R62 ⁴	MF, 1/4W, 1%, 38.3 kΩ	110-38.3k-1
R62 ⁵	MF, 1/4W, 1%, 10.7 kΩ	110-10.7k-1
R62 ⁶	MF, 1/4W, 1%, 10.7 kΩ	110-10.7k-1
R63	MF, 1/4W, 1%, 10 kΩ	110-10k-1
R64	MF, 1/4W, 1%, 10 kΩ	110-10k-1
R65	MF, 1/4W, 1%, 750 kΩ	110-750k-1
R66	MF, 1/4W, 1%, 14.7 kΩ	110-14.7k-1
R67	MF, 1/4W, 1%, 866Ω	110-866-1
R67 ²	MF, 1/4W, 1%, 1.15 kΩ	110-1.15k-1
R67 ³	MF, 1/4W, 1%, 866Ω	110-866-1
R67 ⁴	MF, 1/4W, 1%, 1.15 kΩ	110-1.15k-1
R67 ⁵	MF, 1/4W, 1%, 5.11Ω	110-5.11-1
R67 ⁶	MF, 1/4W, 1%, 866Ω	110-866-1
R68	Variable, 15-Turn, 500Ω	157-500
R69	MF, 1/4W, 1%, 2 kΩ	110-2k-1
R70	MF, 1/4W, 1%, 10 kΩ	110-10k-1
R71	MF, 1/4W, 1%, 750 kΩ	110-750k-1
R72	MF, 1/4W, 1%, 14.7 kΩ	110-14.7k-1
R73	MF, 1/4W, 1%, 10 kΩ	110-10k-1
R74	MF, 1/4W, 1%, 10 kΩ	110-10k-1
R75	MF, 1/4W, 1%, 205 kΩ	110-205k-1
R76	MF, 1/4W, 1%, 511Ω	110-511-1
R77	Variable, 1-Turn, 20Ω	156-20
R78	MF, 1/4W, 1%, 2 kΩ	110-2k-1
R79	MF, 1/4W, 1%, 15 kΩ	110-15k-1
R80	MF, 1/4W, 1%, 511Ω	110-511-1
R81	MF, 1/4W, 1%, 511Ω	110-511-1
R82	MF, 1/4W, 1%, 100 kΩ	110-100k-1
R83	MF, 1/4W, 1%, 100 kΩ	110-100k-1
R84	MF, 1/4W, 1%, 5.11 kΩ	110-5.11k-1
R85	MF, 1/4W, 1%, 5.11 kΩ	110-5.11k-1
R86	MF, 1/4W, 1%, 5.11Ω	110-5.11-1

INTEGRATED CIRCUITS

REF. DES.	DESCRIPTION	WILTRON PART NO.
U1	Quad Analog Switch, LF13201	54-20
U2	NAND Gate, 74LS10	54-42
U3	Op Amp, OP05	54-87
U4	Quad Op Amp, TL072	54-53
U5	2k x 8 EPROM	Not Field-Replaceable
U7	Quad Op Amp, TL074	54-132
U8	Quad Ex. OR Gate, 74LS86	54-125
U9	Dual Volt. Comp., LM393	54-158

MISCELLANEOUS

REF. DES.	DESCRIPTION	WILTRON PART NO.
---	Ejector, PC Board	553-96
TP1 thru TP4	Pin, Test Point	706-44
K1	Relay, 2 Form C	690-28
---	Socket, I.C., 24-Pin	553-67

Table 6-13. A6/A7 YIG Driver, 8-12.4 GHz, 6621A-40/6629A-40/6637A-40
(660-D-8009-14, -17, -99-91, -99-93)

<u>CAPACITORS</u>					
REF. DES.	DESCRIPTION	WILTRON PART NO.			
C1	Tantalum, 4.7 μ F	250-39A	R3	CC, 1/4W, 5%, 3.6 M Ω	101-3.6M-5
C2	Tantalum, 4.7 μ F	250-39A	R4	MF, 1/4W, 1%, 61.9 k Ω	110-61.9k-1
C3	Tantalum, 4.7 μ F	250-39A	R5	Variable, 15-Turn, 1 k Ω	157-1k
C4	Disc Ceramic, .01 μ F	230-11	R6	MF, 1/4W, 1%, 11 k Ω	110-11k-1
C5	Disc Ceramic, .001 μ F	230-30	R7	Variable, 15-Turn, 1 k Ω	157-1k
C6	Monolithic, .1 μ F	230-37	R8	MF, 1/4W, 1%, 11 k Ω	110-11k-1
C7	Monolithic, .1 μ F	230-37	R9	Variable, 15-Turn, 200 k Ω	157-200k
C8	Monolithic, 1.0 μ F	230-41	R10	MF, 1/4W, 1%, 205 k Ω	110-205k-1
C9	Not Used		R11 ¹	MF, 1/4W, 1%, 10.5 k Ω	110-10.5k-1
C10	Monolithic, .1 μ F	230-37	R11 ²	MF, 1/4W, 1%, 10 k Ω	110-10k-1
C11	Tantalum, 6.8 μ F	250-41	R11 ³	MF, 1/4W, 1%, 6.65 k Ω	110-6.65k-1
C12	Mica, 5 pF	220-5	R11 ⁴	MF, 1/4W, 1%, 10 k Ω	110-10k-1
C13	Monolithic, .1 μ F	230-37	R12	MF, 1/4W, 1%, 20 k Ω	110-20k-1
C14	Disc Ceramic, .01 μ F	230-11	R13	Variable, 1-Turn, 20 k Ω	156-20k
C15	Not Used		R14	MF, 1/4W, 1%, 2.74 k Ω	110-2.74k-1
C16	Monolithic, .1 μ F	230-37	R14 ³	MF, 1/4W, 1%, 2.67 k Ω	110-2.67k-1
C17	Disc Ceramic, .01 μ F	230-11	R14 ⁴	MF, 1/4W, 1%, 4.22 k Ω	110-4.22k-1
C18	Disc Ceramic, .01 μ F	230-11	R15	MF, 1/4W, 1%, 10 k Ω	110-10k-1
C19	Disc Ceramic, .01 μ F	230-11	R16	MF, 1/4W, 1%, 4.99 k Ω	110-4.99k-1
C20	Mica, 300 pF	220-300	R17	MF, 1/4W, 1%, 10 k Ω	110-10k-1
			R18	MF, 1/4W, 1%, 23.7 k Ω	110-23.7k-1
			R19	MF, 1/4W, 1%, 1 k Ω	110-1k-1
			R20	MF, 1/4W, 1%, 121 Ω	110-121-1
			R21	MF, 1/4W, 1%, 1 k Ω	110-1k-1
			R22	MF, 1/4W, 1%, 7.5 k Ω	110-7.5k-1
			R23	MF, 1/4W, 1%, 511 Ω	110-511-1
			R24	MF, 1/4W, 1%, 5.11 k Ω	110-5.11k-1
			R25	WW, 5W, 5 Ω	131-3
			R26	MF, 1/4W, 1%, 10 k Ω	110-10k-1
			R27	MF, 1/4W, 1%, 750 Ω	110-750-1
			R28	MF, 1/4W, 1%, 5.49 k Ω	110-5.49k-1
			R29	MF, 1/4W, 1%, 1.78 k Ω	110-1.78k-1
			R30	MF, 1/4W, 1%, 2.15 k Ω	110-2.15k-1
			R31	MF, 1/4W, 1%, 1k	110-1k-1
			R32	MF, 1/4W, 1%, 1.21 k Ω	110-1.21k-1
			R33	MF, 1/4W, 1%, 17.8 k Ω	110-17.8k-1
			R34	Variable, 1-Turn, 200 k Ω	156-200k
			R35	MF, 1/4W, 1%, 1 k Ω	110-1k-1
			R36	MF, 1/4W, 1%, 10 k Ω	110-10k-1
			R37	MF, 1/4W, 1%, 10 k Ω	110-10k-1
			R38	MF, 1/4W, 1%, 18.7 k Ω	110-18.7k-1
			R39	MF, 1/4W, 1%, 18.7 k Ω	110-18.7k-1
			R42	Variable, 15-Turn, 50 k Ω	157-50k
			R43	MF, 1/4W, 1%, 18.7 k Ω	110-18.7k-1
			R44	MF, 1/4W, 1%, 18.7 k Ω	110-18.7k-1
			R45	MF, 1/4W, 1%, 10 k Ω	110-10k-1
			R46	MF, 1/4W, 1%, 9.53 k Ω	110-9.53k-1
			R47	Variable, 15-Turn, 20 k Ω	157-20k
			R48	MF, 1/4W, 1%, 11 k Ω	110-11k-1
			R49	MF, 1/4W, 1%, 10 k Ω	110-10k-1
			R50	MF, 1/4W, 1%, 511 Ω	110-511-1
			R51	MF, 1/4W, 1%, 4.99 k Ω	110-4.99k-1
			R52	MF, 1/4W, 1%, 3.83 k Ω	110-3.83k-1
			R53	MF, 1/4W, 1%, 1 k Ω	110-1k-1
			R54	MF, 1/4W, 1%, 511 Ω	110-511-1
			R55	MF, 1/4W, 1%, 8.66 Ω	110-8.66-1
			R56	MF, 1/4W, 1%, 8.66 Ω	110-8.66-1
			R57	MF, 1/4W, 1%, 8.66 Ω	110-8.66-1
			R58	MF, 1/4W, 1%, 8.66 Ω	110-8.66-1
			R59	MF, 1/4W, 1%, 8.66 Ω	110-8.66-1
			R60	MF, 1/4W, 1%, 2.15 k Ω	110-2.15k-1
			R61 ¹	MF, 1/4W, 1%, 33.2 k Ω	110-33.2k-1
			R61 ²	MF, 1/4W, 1%, 38.3 k Ω	110-38.3k-1
			R61 ³	MF, 1/4W, 1%, 33.2 k Ω	110-33.2k-1
			R61 ⁴	MF, 1/4W, 1%, 33.2 k Ω	110-33.2k-1
			R62 ¹	MF, 1/4W, 1%, 33.2 k Ω	110-33.2k-1

<u>DIODES</u>		
REF. DES.	DESCRIPTION	WILTRON PART NO.
CR1	Silicon, 1N4446	10-1N4446
CR2	Not Used	
CR3	Silicon, SI2	10-SI2
CR4	Zener, 24V, 1W, 1N4749A	10-1N4749A
CR5	Silicon, SI2	10-SI2
CR6	Silicon, 1N4446	10-1N4446
CR7	Silicon, 1N4446	10-1N4446
CR8	Silicon, 1N4446	10-1N4446
CR9	Zener, 10V, 0.4W, 1N758A	10-1N758A
CR10	Silicon, 1N4446	10-1N4446
CR11	Silicon, 1N4446	10-1N4446

<u>TRANSISTORS</u>		
REF. DES.	DESCRIPTION	WILTRON PART NO.
Q1	PNP, MPSA92	20-MPSA92
Q2	PNP, MPSA92	20-MPSA92
Q3	NPN, 2N3694	20-2N3694
Q4	NPN, 2N2222A	20-2N2222A
Q5	NPN, 2N2222A	20-2N2222A
Q6	PNP, 2N2907A	20-2N2907A
Q7	NPN, 2N2222A	20-2N2222A
Q8	NPN, 2N2222A	20-2N2222A

<u>RESISTORS</u>		
REF. DES.	DESCRIPTION	WILTRON PART NO.
R1	CC, 1/4W, 5%, 3.3 M Ω	101-3.3M-5
R2	Variable, 15-Turn, 50 k Ω	157-50k

¹Used on 660-D-8009-14 assembly.
²Used on 660-D-8009-17 assembly.
³Used on 660-D-8009-99-91 assembly.
⁴Used on 660-D-8009-99-93 assembly.

R62 ²	MF, 1/4W, 1%, 38.3 kΩ	110-38.3k-1
R62 ³	MF, 1/4W, 1%, 33.2 kΩ	110-33.2k-1
R62 ¹	MF, 1/4W, 1%, 33.2 kΩ	110-33.2k-1
R63	MF, 1/4W, 1%, 10 kΩ	110-10k-1
R64	MF, 1/4W, 1%, 10 kΩ	110-10k-1
R66	MF, 1/4W, 1%, 14.7 kΩ	110-14.7k-1
R67	MF, 1/4W, 1%, 866Ω	110-866-1
R67 ²	MF, 1/4W, 1%, 5.11Ω	110-5.11-1
R68	Variable, 15-Turn, 500Ω	157-500
R69	MF, 1/4W, 1%, 2 kΩ	110-2k-1
R70	MF, 1/4W, 1%, 10 kΩ	110-10k-1
R72	MF, 1/4W, 1%, 14.7 kΩ	110-14.7k-1
R73	MF, 1/4W, 1%, 10 kΩ	110-10k-1
R74	MF, 1/4W, 1%, 10 kΩ	110-10k-1
R75	MF, 1/4W, 1%, 205 kΩ	110-205k-1
R76	MF, 1/4W, 1%, 511Ω	110-511-1
R77	Variable, 1-Turn, 20Ω	156-20
R78	MF, 1/4W, 1%, 2 kΩ	110-2k-1
R79	MF, 1/4W, 1%, 15 kΩ	110-15k-1
R80	MF, 1/4W, 1%, 511Ω	110-511-1
R81	MF, 1/4W, 1%, 511Ω	110-511-1
R82	MF, 1/4W, 1%, 100 kΩ	110-100k-1
R83	MF, 1/4W, 1%, 100 kΩ	110-100k-1
R84	MF, 1/4W, 1%, 5.11 kΩ	110-5.11k-1
R85	MF, 1/4W, 1%, 5.11 kΩ	110-5.11k-1
R86	MF, 1/4W, 1%, 5.11Ω	110-5.11-1

INTEGRATED CIRCUITS

REF. DES.	DESCRIPTION	WILTRON PART NO.
U1	Quad Analog Switch, LF13201	54-20
U2	NAND Gate, 74LS10	54-42
U3	Op Amp, OP05	54-87
U4	Quad Op Amp, TL072	54-53
U5	2k x 8 EPROM	Not Field-Replaceable
U7	Quad Op Amp, TL074	54-132
U8	Quad Ex. OR Gate, 74LS86	54-125
U9	Dual Volt. Comp., LM393	54-158

MISCELLANEOUS

REF. DES.	DESCRIPTION	WILTRON PART NO.
---	Ejector, PC Board	553-96
TP1 thru TP4	Pin, Test Point	706-44
K1	Relay, 2 Form C	690-28
---	Socket, I.C., 24-Pin	553-67

Table 6-14. A6/A7/A8 YIG Driver, 12.4-18.6 GHz, 6629A-40/6637A-40 (660-D-8009-15, -16, -99-94)

CAPACITORS			TRANSISTORS		
REF. DES.	DESCRIPTION	WILTRON PART NO.	REF. DES.	DESCRIPTION	WILTRON PART NO.
C1	Tantalum, 4.7 μF	250-39A	Q1	PNP, MPSA92	20-MPSA92
C2	Tantalum, 4.7 μF	250-39A	Q2	PNP, MPSA92	20-MPSA92
C3	Tantalum, 4.7 μF	250-39A	Q3	NPN, 2N3694	20-2N3694
C4	Disc Ceramic, .01 μF	230-11	Q4	NPN, 2N2222A	20-2N2222A
C5	Disc Ceramic, .001 μF	230-30	Q5	NPN, 2N2222A	20-2N2222A
C6	Monolithic, .1 μF	230-37	Q6	PNP, 2N2907A	20-2N2907A
C7	Monolithic, .1 μF	230-37	Q7	NPN, 2N2222A	20-2N2222A
C8	Monolithic, 1.0 μF	230-41	Q8	NPN, 2N2222A	20-2N2222A
C9	Not Used				
C10	Monolithic, .1 μF	230-37			
C11	Tantalum, 6.8 μF	250-41			
C12	Mica, 5 pF	220-5			
C13	Monolithic, .1 μF	230-37			
C14	Disc Ceramic, .01 μF	230-11			
C15	Not Used				
C16	Monolithic, .1 μF	230-37			
C17	Disc Ceramic, .01 μF	230-11			
C18	Disc Ceramic, .01 μF	230-11			
C19	Disc Ceramic, .01 μF	230-11			
C20	Mica, 300 pF	220-300			
DIODES			RESISTORS		
REF. DES.	DESCRIPTION	WILTRON PART NO.	REF. DES.	DESCRIPTION	WILTRON PART NO.
CR1	Silicon, 1N4446	10-1N4446	R1	CC, 1/4W, 5%, 3.3 MΩ	101-3.3M-5
CR2	Not Used		R2	Variable, 15-Turn, 50 kΩ	157-50k
CR3	Silicon, SI2	10-SI2	R3	CC, 1/4W, 5%, 3.6 MΩ	101-3.6M-5
CR4	Zener, 24V, 1W, 1N4749A	10-1N4749A	R4	MF, 1/4W, 1%, 61.9 kΩ	110-61.9k-1
			R5	Variable, 15-Turn, 1 kΩ	157-1k
			R6	MF, 1/4W, 1%, 11 kΩ	110-11k-1
			R7	Variable, 15-Turn, 1 kΩ	157-1k
			R8	MF, 1/4W, 1%, 11 kΩ	110-11k-1

¹Used on 660-D-8009-14 assembly.
²Used on 660-D-8009-17 assembly.

R9	Variable, 15-Turn, 200 k Ω	157-200k
R10	MF, 1/4W, 1%, 205 k Ω	110-205k-1
R11 ¹	MF, 1/4W, 1%, 4.64 k Ω	110-4.64k-1
R11 ²	MF, 1/4W, 1%, 4.22 k Ω	110-4.22k-1
R11 ³	MF, 1/4W, 1%, 7.68 k Ω	110-7.68k-1
R12	MF, 1/4W, 1%, 20 k Ω	110-20k-1
R13	Variable, 1-Turn, 20 k Ω	156-20k
R14 ¹	MF, 1/4W, 1%, 1.91 k Ω	110-1.91k-1
R14 ²	MF, 1/4W, 1%, 2.74 k Ω	110-2.74k-1
R14 ³	MF, 1/4W, 1%, 3.16 k Ω	110-3.16k-1
R15	MF, 1/4W, 1%, 10 k Ω	110-10k-1
R16	MF, 1/4W, 1%, 10 k Ω	110-10k-1
R17	MF, 1/4W, 1%, 10 k Ω	110-10k-1
R18	MF, 1/4W, 1%, 23.7 k Ω	110-23.7k-1
R19	MF, 1/4W, 1%, 1 k Ω	110-1k-1
R20	MF, 1/4W, 1%, 121 Ω	110-121-1
R21	MF, 1/4W, 1%, 1 k Ω	110-1k-1
R22	MF, 1/4W, 1%, 7.5 k Ω	110-7.5k-1
R23	MF, 1/4W, 1%, 511 Ω	110-511-1
R24	MF, 1/4W, 1%, 5.11 k Ω	110-5.11k-1
R25	WW, 5W, 2 Ω	131-1
R26	MF, 1/4W, 1%, 10 k Ω	110-10k-1
R27	MF, 1/4W, 1%, 750 Ω	110-750-1
R28	MF, 1/4W, 1%, 5.49 k Ω	110-5.49k-1
R29	MF, 1/4W, 1%, 1.78 k Ω	110-1.78k-1
R30	MF, 1/4W, 1%, 2.15 k Ω	110-2.15k-1
R31	MF, 1/4W, 1%, 1 k Ω	110-1k-1
R32	MF, 1/4W, 1%, 1.21 k Ω	110-1.21k-1
R33	MF, 1/4W, 1%, 17.8 k Ω	110-17.8k-1
R34	Variable, 1-Turn, 200 k Ω	156-200k
R35	MF, 1/4W, 1%, 1 k Ω	110-1k-1
R36	MF, 1/4W, 1%, 10 k Ω	110-10k-1
R37	MF, 1/4W, 1%, 10 k Ω	110-10k-1
R38	MF, 1/4W, 1%, 18.7 k Ω	110-18.7k-1
R39	MF, 1/4W, 1%, 18.7 k Ω	110-18.7k-1
R40 ³	MF, 1/4W, 1%, 61.9 k Ω	110-61.9k-1
R41 ³	MF, 1/4W, 1%, 61.9 k Ω	110-61.9k-1
R42	Variable, 15-Turn, 50 k Ω	157-50k
R43	MF, 1/4W, 1%, 18.7 k Ω	110-18.7k-1
R44	MF, 1/4W, 1%, 18.7 k Ω	110-18.7k-1
R45	MF, 1/4W, 1%, 10 k Ω	110-10k-1
R46 ¹	MF, 1/4W, 1%, 9.53 k Ω	110-9.53k-1
R46 ²	MF, 1/4W, 1%, 9.53 k Ω	110-9.53k-1
R46 ³	MF, 1/4W, 1%, 8.45 k Ω	110-8.45k-1
R47	Variable, 15-Turn, 20 k Ω	157-20k
R48	MF, 1/4W, 1%, 11 k Ω	110-11k-1
R49	MF, 1/4W, 1%, 10 k Ω	110-10k-1
R50	MF, 1/4W, 1%, 511 Ω	110-511-1
R51	MF, 1/4W, 1%, 4.99 k Ω	110-4.99k-1
R52	MF, 1/4W, 1%, 3.83 k Ω	110-3.83k-1
R53	MF, 1/4W, 1%, 1 k Ω	110-1k-1
R54	MF, 1/4W, 1%, 511 Ω	110-511-1
R55	MF, 1/4W, 1%, 8.66 Ω	110-8.66-1
R56	MF, 1/4W, 1%, 8.66 Ω	110-8.66-1
R57	MF, 1/4W, 1%, 8.66 Ω	110-8.66-1
R58	MF, 1/4W, 1%, 8.66 Ω	110-8.66-1

¹ Used on 660-D-8009-15 assembly.

² Used on 660-D-8009-16 assembly

³ Used on 660-D-8009-99-94 assembly.

R59	MF, 1/4W, 1%, 8.66 Ω	110-8.66-1
R60	MF, 1/4W, 1%, 2.15 k Ω	110-2.15k-1
R61 ¹	MF, 1/4W, 1%, 100 k Ω	110-100k-1
R61 ²	MF, 1/4W, 1%, 100 k Ω	110-100k-1
R61 ³	MF, 1/4W, 1%, 33.2 k Ω	110-33.2k-1
R62 ³	MF, 1/4W, 1%, 33.2 k Ω	110-33.2k-1
R63	MF, 1/4W, 1%, 10 k Ω	110-10k-1
R64	MF, 1/4W, 1%, 10 k Ω	110-10k-1
R65	MF, 1/4W, 1%, 750 k Ω	110-750k-1
R66	MF, 1/4W, 1%, 14.7 k Ω	110-14.7k-1
R67 ¹	MF, 1/4W, 1%, 866 Ω	110-866-1
R67 ²	MF, 1/4W, 1%, 866 Ω	110-866-1
R67 ³	MF, 1/4W, 1%, 5.11 Ω	110-5.11-1
R68	Variable, 15-Turn, 500 Ω	157-500
R69	MF, 1/4W, 1%, 2 k Ω	110-2k-1
R70	MF, 1/4W, 1%, 10 k Ω	110-10k-1
R71	MF, 1/4W, 1%, 750 k Ω	110-750k-1
R72	MF, 1/4W, 1%, 14.7 k Ω	110-14.7k-1
R73	MF, 1/4W, 1%, 10 k Ω	110-10k-1
R74	MF, 1/4W, 1%, 10 k Ω	110-10k-1
R75	MF, 1/4W, 1%, 205 k Ω	110-205k-1
R76	MF, 1/4W, 1%, 511 Ω	110-511-1
R77	Variable, 1-Turn, 20 Ω	156-20
R78	MF, 1/4W, 1%, 2 k Ω	110-2k-1
R79	MF, 1/4W, 1%, 15 k Ω	110-15k-1
R80	MF, 1/4W, 1%, 511 Ω	110-511-1
R81	MF, 1/4W, 1%, 511 Ω	110-511-1
R82	MF, 1/4W, 1%, 100 k Ω	110-100k-1
R83	MF, 1/4W, 1%, 100 k Ω	110-100k-1
R84	MF, 1/4W, 1%, 5.11 k Ω	110-5.11k-1
R85	MF, 1/4W, 1%, 5.11 k Ω	110-5.11k-1
R86	MF, 1/4W, 1%, 5.11 Ω	110-5.11-1

INTEGRATED CIRCUITS

REF. DES.	DESCRIPTION	WILTRON PART NO.
U1	Quad Analog Switch, LF13201	54-20
U2	NAND Gate, 74LS10	54-42
U3	Op Amp, OP05	54-87
U4	Quad Op Amp, TL072	54-53
U5	2k x 8 EPROM	Not Field-Replaceable
U7	Quad Op Amp, TL074	54-132
U8	Quad Ex. OR Gate, 74LS86	54-125
U9	Dual Volt. Comp., LM393	54-158

MISCELLANEOUS

REF. DES.	DESCRIPTION	WILTRON PART NO.
---	Ejector, PC Board	553-96
TP1 thru TP4	Pin, Test Point	706-44
K1	Relay, 2 Form C	690-28
---	Socket, I.C., 24-Pin	553-67

Table 6-15. A7/A8 YIG Driver, 12.4-18.6 (20) GHz, 6629A/6637A/6638A/6647A/6648A
(660-D-8008-4, -7, -99-90)

<u>CAPACITORS</u>					
REF. DES.	DESCRIPTION	WILTRON PART NO.			
C1	Tantalum, 4.7 μ F	250-39	R2	Variable, 15-Turn, 50 k Ω	157-50k
C2	Tantalum, 4.7 μ F	250-39	R3	CC, 1/4W, 5%, 3.6 M Ω	101-3.6M-5
C3	Tantalum, 4.7 μ F	250-39	R4	MF, 1/4W, 1%, 61.9 k Ω	110-61.9k-1
C4	Disc Ceramic, .01 μ F	230-11	R5	Variable, 15-Turn, 1 k Ω	157-1k
C5	Disc Ceramic, .001 μ F	230-30	R6	MF, 1/4W, 1%, 11 k Ω	110-11k-1
C6	Tantalum, 1 μ F, 35V	250-19	R7	Variable, 15-Turn, 1 k Ω	157-1k
C7	Tantalum, 1 μ F, 35V	250-19	R8	MF, 1/4W, 1%, 11 k Ω	110-11k-1
C8	Monolithic, 1.0 μ F	230-41	R9	Variable, 15-Turn, 200 k Ω	157-200k
C9	Mica, 300 pF	220-300	R10 ¹	MF, 1/4W, 1%, 210 k Ω	110-210k-1
C10	Monolithic, .1 μ F	230-37	R10 ²	MF, 1/4W, 1%, 205 k Ω	110-205k-1
C11	Tantalum, 6.8 μ F	250-41	R11 ¹	MF, 1/4W, 1%, 5.11 k Ω	110-5.11k-1
C12	Mica, 5 pF	220-5	R11 ²	MF, 1/4W, 1%, 7.68 k Ω	110-7.68k-1
C13	Monolithic, .1 μ F	230-37	R12	MF, 1/4W, 1%, 20 k Ω	110-20k-1
C14	Disc Ceramic, .01 μ F	230-11	R13	Variable, 1-Turn, 20 k Ω	156-20k
C15	Mica, 820 pF	220-820	R14 ¹	MF, 1/4W, 1%, 1.87 k Ω	110-1.87k-1
C16	Monolithic, .1 μ F	230-37	R14 ²	MF, 1/4W, 1%, 3.16 k Ω	110-3.16k-1
C17	Disc Ceramic, .01 μ F	230-11	R15	MF, 1/4W, 1%, 10 k Ω	110-10k-1
C18	Disc Ceramic, .01 μ F	230-11	R16	MF, 1/4W, 1%, 4.99 k Ω	110-4.99k-1
C19	Disc Ceramic, .01 μ F	230-11	R17	MF, 1/4W, 1%, 10 k Ω	110-10k-1
			R18	MF, 1/4W, 1%, 23.7 k Ω	110-23.7k-1
			R19	MF, 1/4W, 1%, 1 k Ω	110-1k-1
			R20	MF, 1/4W, 1%, 121 Ω	110-121-1
			R21	MF, 1/4W, 1%, 1 k Ω	110-1k-1
			R22	MF, 1/4W, 1%, 7.5 k Ω	110-7.5k-1
			R23	MF, 1/4W, 1%, 511 Ω	110-511-1
			R24	MF, 1/4W, 1%, 5.11 k Ω	110-5.11k-1
			R25	WW, 5W, 3 Ω	131-2
			R26	MF, 1/4W, 1%, 10 k Ω	110-10k-1
			R27	MF, 1/4W, 1%, 750 Ω	110-750-1
			R28	MF, 1/4W, 1%, 5.49 k Ω	110-5.49k-1
			R29	MF, 1/4W, 1%, 1.78 k Ω	110-1.78k-1
			R30	MF, 1/4W, 1%, 2.15 k Ω	110-2.15k-1
			R31	MF, 1/4W, 1%, 1k	110-1k-1
			R32	MF, 1/4W, 1%, 1.21 k Ω	110-1.21k-1
			R33	MF, 1/4W, 1%, 17.8 k Ω	110-17.8k-1
			R34	Variable, 1-Turn, 200 k Ω	156-200k
			R35	MF, 1/4W, 1%, 1 k Ω	110-1k-1
			R38	MF, 1/4W, 1%, 18.7 k Ω	110-18.7k-1
			R39	MF, 1/4W, 1%, 18.7 k Ω	110-18.7k-1
			R40	MF, 1/4W, 1%, 10 k Ω	110-10k-1
			R41 ¹	MF, 1/4W, 1%, 110 k Ω	110-110k-1
			R41 ²	MF, 1/4W, 1%, 61.9 k Ω	110-61.9k-1
			R42	Variable, 15-Turn, 50 k Ω	157-50k
			R43	MF, 1/4W, 1%, 18.7 k Ω	110-18.7k-1
			R44	MF, 1/4W, 1%, 18.7 k Ω	110-18.7k-1
			R45	MF, 1/4W, 1%, 10 k Ω	110-10k-1
			R46	MF, 1/4W, 1%, 8.45 k Ω	110-8.45k-1
			R47	Variable, 15-Turn, 10 k Ω	157-10k
			R48	MF, 1/4W, 1%, 11 k Ω	110-11k-1
			R49	MF, 1/4W, 1%, 10 k Ω	110-10k-1
			R50	MF, 1/4W, 1%, 511 Ω	110-511-1
			R51	MF, 1/4W, 1%, 4.99 k Ω	110-4.99k-1
			R52	MF, 1/4W, 1%, 3.83 k Ω	110-3.83k-1
			R53	MF, 1/4W, 1%, 1 k Ω	110-1k-1
			R54	MF, 1/4W, 1%, 511 Ω	110-511-1
			R55	MF, 1/4W, 1%, 8.06 Ω	110-8.66-1
			R56	MF, 1/4W, 1%, 8.06 Ω	110-8.66-1
			R57	MF, 1/4W, 1%, 8.06 Ω	110-8.66-1
			R58	MF, 1/4W, 1%, 8.06 Ω	110-8.66-1
			R59	CC, 1/2W, .5 Ω	102-.5-5
			R60	MF, 1/4W, 1%, 2.15 k Ω	110-2.15k-1
			R61 ¹	MF, 1/4W, 1%, 110 k Ω	110-110k-1
			R61 ²	MF, 1/4W, 1%, 33.2 k Ω	110-33.2k-1
			R62	MF, 1/4W, 1%, 33.2 k Ω	110-33.2k-1
			R63	MF, 1/4W, 1%, 10 k Ω	110-10k-1
			R64	MF, 1/4W, 1%, 10 k Ω	110-10k-1

<u>DIODES</u>		
REF. DES.	DESCRIPTION	WILTRON PART NO.
CR1	Silicon, 1N4446	10-1N4446
CR2	Silicon, 1N4446	10-1N4446
CR3	Silicon, SI2	10-SI2
CR4	Zener, 24V, 1W, 1N4749A	10-1N4749A
CR5	Silicon, SI2	10-SI2
CR6	Silicon, 1N4446	10-1N4446
CR7	Silicon, 1N4446	10-1N4446
CR8	Silicon, 1N4446	10-1N4446
CR9	Zener, 10V, 0.4W, 1N758A	10-1N758A
CR10	Silicon, 1N4446	10-1N4446
CR11	Silicon, 1N4446	10-1N4446

<u>TRANSISTORS</u>		
REF. DES.	DESCRIPTION	WILTRON PART NO.
Q1	PNP, MPSA92	20-MPSA92
Q2	PNP, MPSA92	20-MPSA92
Q3	NPN, 2N3694	20-2N3694
Q4	NPN, 2N2222A	20-2N2222A
Q5	PNP, 2N2907A	20-2N2907A
Q6	NPN, 2N2222A	20-2N2222A
Q7	PNP, 2N2907A	20-2N2907A

<u>RESISTORS</u>		
REF. DES.	DESCRIPTION	WILTRON PART NO.
R1	CC, 1/4W, 5%, 3.3 M Ω	101-3.3M-5

¹Used on 660-D-8008-4 and -7 assemblies.

²Used on 660-D-8008-99-90 assembly.

R65	MF, 1/4W, 1%, 750 k Ω	110-750k-1
R66	MF, 1/4W, 1%, 14.7 k Ω	110-14.7k-1
R67	MF, 1/4W, 1%, 5.11 Ω	110-5.11-1
R68	Variable, 15-Turn, 500 Ω	157-500
R69	MF, 1/4W, 1%, 2 k Ω	110-2k-1
R70	MF, 1/4W, 1%, 10 k Ω	110-10k-1
R71	MF, 1/4W, 1%, 750 k Ω	110-750k-1
R72	MF, 1/4W, 1%, 14.7 k Ω	110-14.7k-1
R73	MF, 1/4W, 1%, 10 k Ω	110-10k-1
R74	MF, 1/4W, 1%, 10 k Ω	110-10k-1
R75	MF, 1/4W, 1%, 205 k Ω	110-205k-1
R76	MF, 1/4W, 1%, 511 Ω	110-511-1
R77	Variable, 1-Turn, 20 Ω	156-20
R78	MF, 1/4W, 1%, 2 k Ω	110-2k-1
R79	MF, 1/4W, 1%, 15 k Ω	110-15k-1
R80	MF, 1/4W, 1%, 511 Ω	110-511-1
R81	MF, 1/4W, 1%, 511 Ω	110-511-1
R82	MF, 1/4W, 1%, 100 k Ω	110-100k-1
R83	MF, 1/4W, 1%, 100 k Ω	110-100k-1
R84	MF, 1/4W, 1%, 5.11 k Ω	110-5.11k-1
R85	MF, 1/4W, 1%, 5.11 k Ω	110-5.11k-1
R86	MF, 1/4W, 1%, 5.11 Ω	110-5.11-1

INTEGRATED CIRCUITS

REF. DES.	DESCRIPTION	WILTRON PART NO.
U1	Quad Analog Switch, LF13201	54-20
U2	NAND Gate, 74LS10	54-42
U3	Op Amp, OP05	54-87
U4	Quad Op Amp, TL072	54-53
U5	2k x 8 EPROM	Not Field-Replaceable
U7	Quad Op Amp, TL074	54-132
U8	Quad Ex. OR Gate, 74LS86	54-125
U9	Dual Volt. Comp., LM393	54-158

MISCELLANEOUS

REF. DES.	DESCRIPTION	WILTRON PART NO.
---	Ejector, PC Board	553-96
TP1 thru TP4	Pin, Test Point	706-44
K1	Relay, 2 Form C	690-28
---	Socket, I.C., 24-Pin	553-67

Table 6-16. A7 YIG Driver, 26.5-40 GHz, 6642A (660-D-8191-99-93)

REF. DES.	DESCRIPTION	WILTRON PART NO.
C1	Tantalum, 4.7 μ F	250-39
C2	Tantalum, 4.7 μ F	250-39
C3	Tantalum, 4.7 μ F	250-39
C4	Disc Ceramic, .01 μ F	230-11
C5	Disc Ceramic, .001 μ F	230-30
C6	Tantalum, 1 μ F, 35V	250-19
C7	Tantalum, 1 μ F, 35V	250-19
C8	Monolithic, 1.0 μ F	230-41
C9	Mica, 300 pF	220-300
C10	Monolithic, .1 μ F	230-37
C11	Tantalum, 6.8 μ F	250-41
C12	Mica, 5 pF	220-5
C13	Monolithic, .1 μ F	230-37
C14	Disc Ceramic, .01 μ F	230-11
C15	Mica, 820 pF	220-820
C16	Monolithic, .1 μ F	230-37
C17	Disc Ceramic, .01 μ F	230-11
C18	Disc Ceramic, .01 μ F	230-11
C19	Disc Ceramic, .01 μ F	230-11
C20	Mica, 39 pF	220-39

DIODES

REF. DES.	DESCRIPTION	WILTRON PART NO.
CR1	Silicon, 1N4446	10-1N4446
CR2	Silicon, 1N4446	10-1N4446
CR3	Silicon, SI2	10-SI2
CR4	Zener, 24V, 1W, 1N4749A	10-1N4749A
CR5	Silicon, SI2	10-SI2
CR6	Silicon, 1N4446	10-1N4446
CR7	Silicon, 1N4446	10-1N4446
CR8	Silicon, 1N4446	10-1N4446

CR9	Zener, 10V, 0.4W, 1N758A	10-1N758A
CR10	Silicon, 1N4446	10-1N4446

TRANSISTORS

REF. DES.	DESCRIPTION	WILTRON PART NO.
Q1	PNP, MPSA92	20-MPSA92
Q2	PNP, MPSA92	20-MPSA92
Q3	PNP, 2N4249	20-2N4249
Q4	PNP, MPSU55	20-30
Q5	PNP, 2N2907A	20-2N2907A
Q6	NPN, 2N2222A	20-2N2222A
Q7	PNP, 2N2907A	20-2N2907A
Q8	PNP, 2N2907A	20-2N2907A

RESISTORS

REF. DES.	DESCRIPTION	WILTRON PART NO.
R1	CC, 1/4W, 5%, 3.3 M Ω	101-3.3M-5
R2	Variable, 15-Turn, 50 k Ω	157-50k
R3	CC, 1/4W, 5%, 3.6 M Ω	101-3.6M-5
R4	MF, 1/4W, 1%, 61.9 k Ω	110-61.9k-1
R5	Variable, 15-Turn, 1 k Ω	157-1k
R6	MF, 1/4W, 1%, 10 k Ω	110-10k-1
R7	Variable, 1-Turn, 1 k Ω	157-1k
R8	MF, 1/4W, 1%, 10 k Ω	110-10k-1
R9	Variable, 1-Turn, 200 k Ω	157-200k
R10	MF, 1/4W, 1%, 162 k Ω	110-162k-1
R11	MF, 1/4W, 1%, 3.16 k Ω	110-3.16k-1
R12	MF, 1/4W, 1%, 20 k Ω	110-20k-1
R13	Variable, 1-Turn, 20 k Ω	156-20k
R14	MF, 1/4W, 1%, 2.05 k Ω	110-2.05k-1
R15	MF, 1/4W, 1%, 10 k Ω	110-10k-1
R16	MF, 1/4W, 1%, 10 k Ω	110-10k-1
R17	MF, 1/4W, 1%, 10 k Ω	110-10k-1

R18	MF, 1/4W, 1%, 23.7 kΩ	110-23.7k-1	R66	MF, 1/4W, 1%, 14.7 kΩ	110-14.7k-1
R19	MF, 1/4W, 1%, 1 kΩ	110-1k-1	R67	MF, 1/4W, 1%, 5.11Ω	110-5.11-1
R20	MF, 1/4W, 1%, 121Ω	110-121-1	R68	Variable, 1-Turn, 500Ω	157-500
R21	MF, 1/4W, 1%, 1 kΩ	110-1k-1	R69	MF, 1/4W, 1%, 2 kΩ	110-2k-1
R22	MF, 1/4W, 1%, 7.5 kΩ	110-7.5k-1	R70	MF, 1/4W, 1%, 10 kΩ	110-10k-1
R23	MF, 1/4W, 1%, 511Ω	110-511-1	R71	MF, 1/4W, 1%, 750 kΩ	110-750k-1
R24	MF, 1/4W, 1%, 5.11 kΩ	110-5.11k-1	R72	MF, 1/4W, 1%, 14.7 kΩ	110-14.7k-1
R25	WW, 5W, 5Ω	131-3	R73	MF, 1/4W, 1%, 2 kΩ	110-2k-1
R26	MF, 1/4W, 1%, 15.4 kΩ	110-15k-1	R74	MF, 1/4W, 1%, 10 kΩ	110-10k-1
R27	MF, 1/4W, 1%, 649Ω	110-649-1	R75	MF, 1/4W, 1%, 750 kΩ	110-750k-1
R28	MF, 1/4W, 1%, 6.19 kΩ	110-6.19k-1	R76	MF, 1/4W, 1%, 511Ω	110-511-1
R29	MF, 1/4W, 1%, 1.37 kΩ	110-1.37k-1	R77	Variable, 1-Turn, 20Ω	156-20
R30	MF, 1/4W, 1%, 3.83 kΩ	110-3.83k-1	R78	MF, 1/4W, 1%, 10 kΩ	110-10k-1
R31	MF, 1/4W, 1%, 1 kΩ	110-1k-1	R79	MF, 1/4W, 1%, 14.7 kΩ	110-14.7k-1
R32	MF, 1/4W, 1%, 1.21 kΩ	110-1.21k-1	R80	MF, 1/4W, 1%, 23.7 kΩ	110-23.7k-1
R33	MF, 1/4W, 1%, 17.8 kΩ	110-17.8k-1	R81	MF, 1/4W, 1%, 23.7 kΩ	110-23.7k-1
R34	Variable, 1-Turn, 500 kΩ	156-500k	R82	MF, 1/4W, 1%, 20 kΩ	110-20k-1
R35	MF, 1/4W, 1%, 49.9 kΩ	110-49.9k-1	R83	MF, 1/4W, 1%, 20 kΩ	110-20k-1
R36	MF, 1/4W, 1%, 5.11 kΩ	110-5.11k-1	R84	MF, 1/4W, 1%, 5.11 kΩ	110-5.11k-1
R37	MF, 1/4W, 1%, 5.11 kΩ	110-5.11k-1	R85	MF, 1/4W, 1%, 5.11 kΩ	110-5.11k-1
R38	MF, 1/4W, 1%, 3.87 kΩ	110-18.7k-1	R86	MF, 1/4W, 1%, 5.11Ω	110-5.11-1
R39	MF, 1/4W, 1%, 18.7 kΩ	110-18.7k-1			
R40	MF, 1/4W, 1%, 10 kΩ	110-10k-1			
R41	MF, 1/4W, 1%, 100 kΩ	110-100k-1			
R42	Variable, 1-Turn, 50 kΩ	157-50k			
R43	MF, 1/4W, 1%, 18.7 kΩ	110-18.7k-1			
R44	MF, 1/4W, 1%, 18.7 kΩ	110-18.7k-1			
R45	MF, 1/4W, 1%, 10 kΩ	110-10k-1			
R46	MF, 1/4W, 1%, 8.45 kΩ	110-8.45k-1			
R47	Variable, 1-Turn, 10 kΩ	157-10k			
R48	MF, 1/4W, 1%, 11 kΩ	110-11k-1			
R49	MF, 1/4W, 1%, 10 kΩ	110-10k-1			
R50	MF, 1/4W, 1%, 511Ω	110-511-1			
R51	MF, 1/4W, 1%, 4.99 kΩ	110-4.99k-1			
R52	MF, 1/4W, 1%, 3.83 kΩ	110-3.83k-1			
R53	MF, 1/4W, 1%, 1 kΩ	110-1k-1			
R54	MF, 1/4W, 1%, 511Ω	110-511-1			
R55	MF, 1/4W, 1%, 5.11Ω	110-5.11-1			
R56	MF, 1/4W, 1%, 5.11Ω	110-5.11-1			
R57	MF, 1/4W, 1%, 5.11Ω	110-5.11-1			
R58	MF, 1/4W, 1%, 5.11Ω	110-5.11-1			
R59	CC, 1/2W, 5%, .5Ω	102-.5-5			
R60	MF, 1/4W, 1%, 2.15 kΩ	110-2.15k-1			
R61	MF, 1/4W, 1%, 511Ω	110-511-1			
R62	MF, 1/4W, 1%, 12.1 kΩ	110-12.1k-1			
R63	MF, 1/4W, 1%, 10 kΩ	110-10k-1			
R64	MF, 1/4W, 1%, 10 kΩ	110-10k-1			
R65	MF, 1/4W, 1%, 750 kΩ	110-750k-1			

<u>INTEGRATED CIRCUITS</u>		
REF. DES.	DESCRIPTION	WILTRON PART NO.
U1	Quad Analog Switch, LF13201	54-20
U2	NAND Gate, 74LS10	54-42
U3	Op Amp, OP05	54-87
U4	Quad Op Amp, TL072	54-53
U5	256 x 4 PROM	Not Field-Replaceable
U7	Quad Op Amp, TL074	54-132
U8	Quad Ex. OR Gate, 74LS86	54-125
U9	Dual Volt. Comp., LM393	54-158

<u>MISCELLANEOUS</u>		
REF. DES.	DESCRIPTION	WILTRON PART NO.
---	Ejector, PC Board	553-96
TP1 thru TP4	Pin, Test Point	706-44
K1	Relay, 2 Form C	690-28
---	Socket, I.C., 24-Pin	553-67

Table 6-17. A7 YIG Driver, 8-12.4 GHz, 6653A/6659A (660-D-8009-9, -12)

<u>CAPACITORS</u>		
REF. DES.	DESCRIPTION	WILTRON PART NO.
C1	Tantalum, 4.7 μF	250-39
C2	Tantalum, 4.7 μF	250-39
C3	Tantalum, 4.7 μF	250-39
C4	Disc Ceramic, .01 μF	230-11
C5	Disc Ceramic, .001 μF	230-30
C6	Tantalum, 1 μF, 35V	250-19
C7	Tantalum, 1 μF, 35V	250-19
C8	Monolithic, 1.0 μF	230-41
C9	Mica, 300 pF	220-300
C10	Monolithic, .1 μF	230-37
C11	Tantalum, 6.8 μF	250-41
C12	Mica, 5 pF	220-5

C13	Monolithic, .1 μF	230-37
C14	Disc Ceramic, .01 μF	230-11
C16	Monolithic, .1 μF	230-37
C17	Disc Ceramic, .01 μF	230-11
C18	Disc Ceramic, .01 μF	230-11
C19	Disc Ceramic, .01 μF	230-11
C20	Mica, 820 pF	220-820

<u>DIODES</u>		
REF. DES.	DESCRIPTION	WILTRON PART NO.
CR1	Silicon, 1N4446	10-1N4446
CR2	Silicon, 1N4446	10-1N4446
CR3	Silicon, SI2	10-SI2
CR4	Zener, 24V, 1W, 1N4749A	10-1N4749A

CR5	Silicon, SI2	10-SI2
CR6	Silicon, 1N4446	10-1N4446
CR7	Silicon, 1N4446	10-1N4446
CR8	Silicon, 1N4446	10-1N4446
CR9	Zener, 10V, 0.4W, 1N758A	10-1N758A
CR10	Silicon, 1N4446	10-1N4446
CR11	Silicon, 1N4446	10-1N4446

TRANSISTORS

REF. DES.	DESCRIPTION	WILTRON PART NO.
Q1	PNP, MP5A92	20-MP5A92
Q2	PNP, MP5A92	20-MP5A92
Q3	PNP, 2N3694	20-2N3694
Q4	NPN, 2N2222A	20-2N2222A
Q5	NPN, 2N2222A	20-2N2222A
Q6	PNP, 2N2907A	20-2N2907A
Q7	NPN, 2N2222A	20-2N2222A

RESISTORS

REF. DES.	DESCRIPTION	WILTRON PART NO.
R1	CC, 1/4W, 5%, 3.3 M Ω	101-3.3M-5
R2	Variable, 15-Turn, 50 k Ω	157-50k
R3	CC, 1/4W, 5%, 3.6 M Ω	101-3.6M-5
R4	MF, 1/4W, 1%, 61.9 k Ω	110-61.9k-1
R5	Variable, 15-Turn, 1 k Ω	157-1k
R7	Variable, 15-Turn, 1 k Ω	157-1k
R9	Variable, 15-Turn, 200 k Ω	157-200k
R10	MF, 1/4W, 1%, 205 k Ω	110-205k-1
R11 ¹	MF, 1/4W, 1%, 14.7 k Ω	110-14.7k-1
R11 ²	MF, 1/4W, 1%, 14 k Ω	110-14k-1
R12	MF, 1/4W, 1%, 20 k Ω	110-20k-1
R13	Variable, 1-Turn, 20 k Ω	156-20k
R14	MF, 1/4W, 1%, 2.61 k Ω	110-2.61k-1
R15	MF, 1/4W, 1%, 10 k Ω	110-10k-1
R16	MF, 1/4W, 1%, 4.99 k Ω	110-4.99k-1
R17	MF, 1/4W, 1%, 10 k Ω	110-10k-1
R18	MF, 1/4W, 1%, 23.7 k Ω	110-23.7k-1
R19	MF, 1/4W, 1%, 1 k Ω	110-1k-1
R20	MF, 1/4W, 1%, 121 Ω	110-121-1
R21	MF, 1/4W, 1%, 1 k Ω	110-1k-1
R22	MF, 1/4W, 1%, 7.5 k Ω	110-7.5k-1
R23	MF, 1/4W, 1%, 511 Ω	110-511-1
R24	MF, 1/4W, 1%, 5.11 k Ω	110-5.11k-1
R25	WW, 5W, 5 Ω	131-3
R26	MF, 1/4W, 1%, 10 k Ω	110-10k-1
R27	MF, 1/4W, 1%, 750 Ω	110-750-1
R28	MF, 1/4W, 1%, 5.49 k Ω	110-5.49k-1
R29	MF, 1/4W, 1%, 1.78 k Ω	110-1.78k-1
R30	MF, 1/4W, 1%, 2.15 k Ω	110-2.15k-1
R31	MF, 1/4W, 1%, 1 k Ω	110-1k-1
R32	MF, 1/4W, 1%, 1.21 k Ω	110-1.21k-1
R33	MF, 1/4W, 1%, 17.8 k Ω	110-17.8k-1
R34	Variable, 1-Turn, 200 k Ω	156-200k
R35	MF, 1/4W, 1%, 1 k Ω	110-1k-1
R38	MF, 1/4W, 1%, 18.7 k Ω	110-18.7k-1
R39	MF, 1/4W, 1%, 18.7 k Ω	110-18.7k-1
R42	Variable, 15-Turn, 50 k Ω	157-50k
R43	MF, 1/4W, 1%, 18.7 k Ω	110-18.7k-1
R44	MF, 1/4W, 1%, 18.7 k Ω	110-18.7k-1
R45	MF, 1/4W, 1%, 10 k Ω	110-10k-1
R46	MF, 1/4W, 1%, 9.53 k Ω	110-9.53k-1

¹Used on 660-D-8009-9 assembly.
²Used on 660-D-8009-12 assembly.

R47	Variable, 15-Turn, 1 k Ω	157-1k
R48	MF, 1/4W, 1%, 11 k Ω	110-11k-1
R49	MF, 1/4W, 1%, 10 k Ω	110-10k-1
R50	MF, 1/4W, 1%, 511 Ω	110-511-1
R51	MF, 1/4W, 1%, 4.99 k Ω	110-4.99k-1
R52	MF, 1/4W, 1%, 3.83 k Ω	110-3.83k-1
R53	MF, 1/4W, 1%, 1 k Ω	110-1k-1
R54	MF, 1/4W, 1%, 511 Ω	110-511-1
R55	MF, 1/4W, 1%, 6.19 Ω	110-6.19-1
R56	MF, 1/4W, 1%, 6.19 Ω	110-6.19-1
R57	MF, 1/4W, 1%, 6.19 Ω	110-6.19-1
R58	MF, 1/4W, 1%, 6.19 Ω	110-6.19-1
R59	MF, 1/4W, 1%, 6.19 Ω	110-6.19-1
R60	MF, 1/4W, 1%, 2.15 k Ω	110-2.15k-1
R61 ¹	MF, 1/4W, 1%, 33.2 k Ω	110-33.2k-1
R61 ²	MF, 1/4W, 1%, 38.3 k Ω	110-38.3k-1
R62 ¹	MF, 1/4W, 1%, 33.2 k Ω	110-33.2k-1
R62 ²	MF, 1/4W, 1%, 38.3 k Ω	110-38.3k-1
R63	MF, 1/4W, 1%, 10 k Ω	110-10k-1
R64	MF, 1/4W, 1%, 10 k Ω	110-10k-1
R65	MF, 1/4W, 1%, 750 k Ω	110-750k-1
R66	MF, 1/4W, 1%, 14.7 k Ω	110-14.7k-1
R67	MF, 1/4W, 1%, 2.26 k Ω	110-2.26k-1
R68	Variable, 15-Turn, 500 Ω	157-500
R69	MF, 1/4W, 1%, 2 k Ω	110-2k-1
R70	MF, 1/4W, 1%, 10 k Ω	110-10k-1
R71	MF, 1/4W, 1%, 750 k Ω	110-750k-1
R72	MF, 1/4W, 1%, 14.7 k Ω	110-14.7k-1
R73	MF, 1/4W, 1%, 10 k Ω	110-10k-1
R74	MF, 1/4W, 1%, 10 k Ω	110-10k-1
R75	MF, 1/4W, 1%, 205 k Ω	110-205k-1
R76	MF, 1/4W, 1%, 511 Ω	110-511-1
R77	Variable, 1-Turn, 20 Ω	156-20
R78	MF, 1/4W, 1%, 2 k Ω	110-2k-1
R79	MF, 1/4W, 1%, 15 k Ω	110-15k-1
R80	MF, 1/4W, 1%, 511 Ω	110-511-1
R81	MF, 1/4W, 1%, 511 Ω	110-511-1
R82	MF, 1/4W, 1%, 100 k Ω	110-100k-1
R83	MF, 1/4W, 1%, 100 k Ω	110-100k-1
R84	MF, 1/4W, 1%, 5.11 k Ω	110-5.11k-1
R85	MF, 1/4W, 1%, 5.11 k Ω	110-5.11k-1
R86	MF, 1/4W, 1%, 5.11 Ω	110-5.11-1

INTEGRATED CIRCUITS

REF. DES.	DESCRIPTION	WILTRON PART NO.
U1	Quad Analog Switch, LF13201	54-20
U2	NAND Gate, 74LS10	54-42
U3	Op Amp, OP05	54-87
U4	Quad Op Amp, TL072	54-53
U5	2k x 8 EPROM	Not Field-Replaceable
U7	Quad Op Amp, TL074	54-132
U8	Quad Ex. OR Gate, 74LS86	54-125
U9	Dual Volt. Comp., LM393	54-158

MISCELLANEOUS

REF. DES.	DESCRIPTION	WILTRON PART NO.
---	Ejector, PC Board	553-96
TP1 thru TP4	Pin, Test Point	706-44
K1	Relay, 2 Form C	690-28
---	Socket, I.C., 24-Pin	553-67

Table 6-18. A8 YIG Driver, 12.4-18.6 GHz, 6653A/6659A (660-D-8009-10, -13)

<u>CAPACITORS</u>					
REF. DES.	DESCRIPTION	WILTRON PART NO.			
C1	Tantalum, 4.7 μ F	250-39	R5	Variable, 15-Turn, 1 k Ω	157-1k
C2	Tantalum, 4.7 μ F	250-39	R7	Variable, 15-Turn, 1 k Ω	157-1k
C3	Tantalum, 4.7 μ F	250-39	R9	Variable, 15-Turn, 200 k Ω	157-200k
C4	Disc Ceramic, .01 μ F	230-11	R10	MF, 1/4W, 1%, 205 k Ω	110-205k-1
C5	Disc Ceramic, .001 μ F	230-30	R11 ¹	MF, 1/4W, 1%, 6.19 k Ω	110-6.19k-1
C6	Tantalum, 1 μ F, 35V	250-19	R11 ²	MF, 1/4W, 1%, 6.81 k Ω	110-6.81k-1
C7	Tantalum, 1 μ F, 35V	250-19	R12	MF, 1/4W, 1%, 20 k Ω	110-20k-1
C8	Monolithic, 1.0 μ F	230-41	R13	Variable, 1-Turn, 20 k Ω	156-20k
C9	Mica, 300 pF	220-300	R14 ¹	MF, 1/4W, 1%, 1.78 k Ω	110-1.78k-1
C10	Monolithic, .1 μ F	230-37	R14 ²	MF, 1/4W, 1%, 1.87 k Ω	110-1.87k-1
C11	Tantalum, 6.8 μ F	250-41A	R15	MF, 1/4W, 1%, 10 k Ω	110-10k-1
C12	Mica, 5 pF	220-5	R16	MF, 1/4W, 1%, 4.99 k Ω	110-4.99k-1
C13	Monolithic, .1 μ F	230-37	R17	MF, 1/4W, 1%, 10 k Ω	110-10k-1
C14	Disc Ceramic, .01 μ F	230-11	R18	MF, 1/4W, 1%, 23.7 k Ω	110-23.7k-1
C16	Monolithic, .1 μ F	230-37	R19	MF, 1/4W, 1%, 1 k Ω	110-1k-1
C17	Disc Ceramic, .01 μ F	230-11	R20	MF, 1/4W, 1%, 121 Ω	110-121-1
C18	Disc Ceramic, .01 μ F	230-11	R21	MF, 1/4W, 1%, 1 k Ω	110-1k-1
C19	Disc Ceramic, .01 μ F	230-11	R22	MF, 1/4W, 1%, 7.5 k Ω	110-7.5k-1
C20	Mica, 820 pF	220-820	R23	MF, 1/4W, 1%, 511 Ω	110-511-1
			R24	MF, 1/4W, 1%, 5.11 k Ω	110-5.11k-1
			R25	WW, 5W, 2 Ω	131-1
			R26	MF, 1/4W, 1%, 10 k Ω	110-10k-1
			R27	MF, 1/4W, 1%, 750 Ω	110-750-1
			R28	MF, 1/4W, 1%, 5.49 k Ω	110-5.49k-1
			R29	MF, 1/4W, 1%, 1.78 k Ω	110-1.78k-1
			R30	MF, 1/4W, 1%, 2.15 k Ω	110-2.15k-1
			R31	MF, 1/4W, 1%, 1 k Ω	110-1k-1
			R32	MF, 1/4W, 1%, 1.21 k Ω	110-1.21k-1
			R33	MF, 1/4W, 1%, 17.8 k Ω	110-17.8k-1
			R34	Variable, 1-Turn, 200 k Ω	156-200k
			R35	MF, 1/4W, 1%, 1 k Ω	110-1k-1
			R38	MF, 1/4W, 1%, 18.7 k Ω	110-18.7k-1
			R39	MF, 1/4W, 1%, 18.7 k Ω	110-18.7k-1
			R42	Variable, 15-Turn, 50 k Ω	157-50k
			R43	MF, 1/4W, 1%, 18.7 k Ω	110-18.7k-1
			R44	MF, 1/4W, 1%, 18.7 k Ω	110-18.7k-1
			R45	MF, 1/4W, 1%, 10 k Ω	110-10k-1
			R46	MF, 1/4W, 1%, 9.53 k Ω	110-9.53k-1
			R47	Variable, 15-Turn, 1 k Ω	157-1k
			R48	MF, 1/4W, 1%, 11 k Ω	110-11k-1
			R49	MF, 1/4W, 1%, 10 k Ω	110-10k-1
			R50	MF, 1/4W, 1%, 511 Ω	110-511-1
			R51	MF, 1/4W, 1%, 4.99 k Ω	110-4.99k-1
			R52	MF, 1/4W, 1%, 3.83 k Ω	110-3.83k-1
			R53	MF, 1/4W, 1%, 1 k Ω	110-1k-1
			R54	MF, 1/4W, 1%, 511 Ω	110-511-1
			R55	MF, 1/4W, 1%, 6.19 Ω	110-6.19-1
			R56	MF, 1/4W, 1%, 6.19 Ω	110-6.19-1
			R57	MF, 1/4W, 1%, 6.19 Ω	110-6.19-1
			R58	MF, 1/4W, 1%, 6.19 Ω	110-6.19-1
			R59	MF, 1/4W, 1%, 6.19 Ω	110-6.19-1
			R60	MF, 1/4W, 1%, 2.15 k Ω	110-2.15k-1
			R61	MF, 1/4W, 1%, 100 k Ω	110-100k-1
			R63	MF, 1/4W, 1%, 10 k Ω	110-10k-1
			R64	MF, 1/4W, 1%, 10 k Ω	110-10k-1
			R65	MF, 1/4W, 1%, 750 k Ω	110-750k-1
			R66	MF, 1/4W, 1%, 14.7 k Ω	110-14.7k-1
			R67	MF, 1/4W, 1%, 825 Ω	110-825-1
			R68	Variable, 15-Turn, 500 Ω	157-500
			R69	MF, 1/4W, 1%, 2 k Ω	110-2k-1
			R70	MF, 1/4W, 1%, 10 k Ω	110-10k-1
			R71	MF, 1/4W, 1%, 750 k Ω	110-750k-1
			R72	MF, 1/4W, 1%, 14.7 k Ω	110-14.7k-1
			R73	MF, 1/4W, 1%, 10 k Ω	110-10k-1
			R74	MF, 1/4W, 1%, 10 k Ω	110-10k-1
			R75	MF, 1/4W, 1%, 205 k Ω	110-205k-1
			R76	MF, 1/4W, 1%, 511 Ω	110-511-1
			R77	Variable, 1-Turn, 20 Ω	156-20

<u>DIODES</u>		
REF. DES.	DESCRIPTION	WILTRON PART NO.
CR1	Silicon, 1N4446	10-1N4446
CR2	Silicon, 1N4446	10-1N4446
CR3	Silicon, SI2	10-SI2
CR4	Zener, 24V, 1W, 1N4749A	10-1N4749A
CR5	Silicon, SI2	10-SI2
CR6	Silicon, 1N4446	10-1N4446
CR7	Silicon, 1N4446	10-1N4446
CR8	Silicon, 1N4446	10-1N4446
CR9	Zener, 10V, 0.4W, 1N758A	10-1N758A
CR10	Silicon, 1N4446	10-1N4446
CR11	Silicon, 1N4446	10-1N4446

<u>TRANSISTORS</u>		
REF. DES.	DESCRIPTION	WILTRON PART NO.
Q1	PNP, MPSA92	20-MPSA92
Q2	PNP, MPSA92	20-MPSA92
Q3	PNP, 2N3694	20-2N3694
Q4	NPN, 2N2222A	20-2N2222A
Q5	NPN, 2N2222A	20-2N2222A
Q6	PNP, 2N2907A	20-2N2907A
Q7	NPN, 2N2222A	20-2N2222A

<u>RESISTORS</u>		
REF. DES.	DESCRIPTION	WILTRON PART NO.
R1	CC, 1/4W, 5%, 3.3 M Ω	101-3.3M-5
R2	Variable, 15-Turn, 50 k Ω	157-50k
R3	CC, 1/4W, 5%, 3.6 M Ω	101-3.6M-5
R4	MF, 1/4W, 1%, 61.9 k Ω	110-61.9k-1

¹Used on 660-D-8009-10 assembly.

²Used on 660-D-8009-13 assembly.

R78	MF, 1/4W, 1%, 2 k Ω	110-2k-1
R79	MF, 1/4W, 1%, 15 k Ω	110-15k-1
R80	MF, 1/4W, 1%, 511 Ω	110-511-1
R81	MF, 1/4W, 1%, 511 Ω	110-511-1
R82	MF, 1/4W, 1%, 100 k Ω	110-100k-1
R83	MF, 1/4W, 1%, 100 k Ω	110-100k-1
R84	MF, 1/4W, 1%, 5.11 k Ω	110-5.11k-1
R85	MF, 1/4W, 1%, 5.11 k Ω	110-5.11k-1
R86	MF, 1/4W, 1%, 5.11 Ω	110-5.11-1

INTEGRATED CIRCUITS

REF. DES.	DESCRIPTION	WILTRON PART NO.
U1	Quad Analog Switch, LF13201	54-20
U2	NAND Gate, 74LS10	54-42

U3	Op Amp, OP05	54-87
U4	Quad Op Amp, TL072	54-53
U5	2k x 8 EPROM	Not Field-Replaceable
U7	Quad Op Amp, TL074	54-132
U8	Quad Ex. OR Gate, 74LS86	54-125
U9	Dual Volt. Comp., LM393	54-158

MISCELLANEOUS

REF. DES.	DESCRIPTION	WILTRON PART NO.
---	Ejector, PC Board	553-96
TP1 thru TP4	Pin, Test Point	706-44
K1	Relay, 2 Form C	690-28
---	Socket, I.C., 24-Pin	553-67

Table 6-19. A9 YIG Driver, 18-26.5 GHz, 6653A/6659A (660-D-8009-11)

CAPACITORS

REF. DES.	DESCRIPTION	WILTRON PART NO.
C1	Tantalum, 4.7 μ F	250-39
C2	Tantalum, 4.7 μ F	250-39
C3	Tantalum, 4.7 μ F	250-39
C4	Disc Ceramic, .01 μ F	230-11
C5	Disc Ceramic, .001 μ F	230-30
C6	Tantalum, 1 μ F, 35V	250-19
C7	Tantalum, 1 μ F, 35V	250-19
C8	Monolithic, 1.0 μ F	230-41
C9	Mica, 300 pF	220-300
C10	Monolithic, .1 μ F	230-37
C11	Tantalum, 6.8 μ F	250-41A
C12	Mica, 5 pF	220-5
C13	Monolithic, .1 μ F	230-37
C14	Disc Ceramic, .01 μ F	230-11
C16	Monolithic, .1 μ F	230-37
C17	Disc Ceramic, .01 μ F	230-11
C18	Disc Ceramic, .01 μ F	230-11
C19	Disc Ceramic, .01 μ F	230-11
C20	Mica, 820 pF	220-820

DIODES

REF. DES.	DESCRIPTION	WILTRON PART NO.
CR1	Silicon, 1N4446	10-1N4446
CR2	Silicon, 1N4446	10-1N4446
CR3	Silicon, SI2	10-SI2
CR4	Zener, 24V, 1W, 1N4749A	10-1N4749A
CR5	Silicon, SI2	10-SI2
CR6	Silicon, 1N4446	10-1N4446
CR7	Silicon, 1N4446	10-1N4446
CR8	Silicon, 1N4446	10-1N4446
CR9	Zener, 10V, 0.4W, 1N758A	10-1N758A
CR10	Silicon, 1N4446	10-1N4446
CR11	Silicon, 1N4446	10-1N4446

TRANSISTORS

REF. DES.	DESCRIPTION	WILTRON PART NO.
Q1	PNP, MPSA92	20-MPSA92
Q2	PNP, MPSA92	20-MPSA92
Q3	PNP, 2N3694	20-2N3694
Q4	NPN, 2N2222A	20-2N2222A
Q5	NPN, 2N2222A	20-2N2222A
Q6	PNP, 2N2907A	20-2N2907A
Q7	NPN, 2N2222A	20-2N2222A

RESISTORS

REF. DES.	DESCRIPTION	WILTRON PART NO.
R1	CC, 1/4W, 5%, 3.3 M Ω	101-3.3M-5
R2	Variable, 15-Turn, 50 k Ω	157-50k
R3	CC, 1/4W, 5%, 3.6 M Ω	101-3.6M-5
R4	MF, 1/4W, 1%, 61.9 k Ω	110-61.9k-1
R5	Variable, 15-Turn, 1 k Ω	157-1k
R7	Variable, 15-Turn, 1 k Ω	157-1k
R9	Variable, 15-Turn, 200 k Ω	157-200k
R10	MF, 1/4W, 1%, 205 k Ω	110-205k-1
R11	MF, 1/4W, 1%, 4.02 k Ω	110-4.02k-1
R12	MF, 1/4W, 1%, 20 k Ω	110-20k-1
R13	Variable, 1-Turn, 20 k Ω	156-20k
R14	MF, 1/4W, 1%, 1.54 k Ω	110-1.54k-1
R15	MF, 1/4W, 1%, 10 k Ω	110-10k-1
R16	MF, 1/4W, 1%, 4.99 k Ω	110-4.99k-1
R17	MF, 1/4W, 1%, 10 k Ω	110-10k-1
R18	MF, 1/4W, 1%, 23.7 k Ω	110-23.7k-1
R19	MF, 1/4W, 1%, 1 k Ω	110-1k-1
R20	MF, 1/4W, 1%, 121 Ω	110-121-1
R21	MF, 1/4W, 1%, 1 k Ω	110-1k-1
R22	MF, 1/4W, 1%, 7.5 k Ω	110-7.5k-1
R23	MF, 1/4W, 1%, 511 Ω	110-511-1
R24	MF, 1/4W, 1%, 5.11 k Ω	110-5.11k-1
R25	WW, 5W, 2 Ω	131-1
R26	MF, 1/4W, 1%, 10 k Ω	110-10k-1

R27	MF, 1/4W, 1%, 750Ω	110-750-1
R28	MF, 1/4W, 1%, 5.49 kΩ	110-5.49k-1
R29	MF, 1/4W, 1%, 1.78 kΩ	110-1.78k-1
R30	MF, 1/4W, 1%, 2.15 kΩ	110-2.15k-1
R31	MF, 1/4W, 1%, 1 kΩ	110-1k-1
R32	MF, 1/4W, 1%, 1.21 kΩ	110-1.21k-1
R33	MF, 1/4W, 1%, 17.8 kΩ	110-17.8k-1
R34	Variable, 1-Turn, 200 kΩ	156-200k
R35	MF, 1/4W, 1%, 1 kΩ	110-1k-1
R38	MF, 1/4W, 1%, 18.7 kΩ	110-18.7k-1
R39	MF, 1/4W, 1%, 18.7 kΩ	110-18.7k-1
R42	Variable, 15-Turn, 50 kΩ	157-50k
R43	MF, 1/4W, 1%, 18.7 kΩ	110-18.7k-1
R44	MF, 1/4W, 1%, 18.7 kΩ	110-18.7k-1
R45	MF, 1/4W, 1%, 10 kΩ	110-10k-1
R46	MF, 1/4W, 1%, 9.53 kΩ	110-9.53k-1
R47	Variable, 15-Turn, 1 kΩ	157-1k
R48	MF, 1/4W, 1%, 11 kΩ	110-11k-1
R49	MF, 1/4W, 1%, 10 kΩ	110-10k-1
R50	MF, 1/4W, 1%, 511Ω	110-511-1
R51	MF, 1/4W, 1%, 4.99 kΩ	110-4.99k-1
R52	MF, 1/4W, 1%, 3.83 kΩ	110-3.83k-1
R53	MF, 1/4W, 1%, 1 kΩ	110-1k-1
R54	MF, 1/4W, 1%, 511Ω	110-511-1
R55	MF, 1/4W, 1%, 6.19Ω	110-6.19-1
R56	MF, 1/4W, 1%, 6.19Ω	110-6.19-1
R57	MF, 1/4W, 1%, 6.19Ω	110-6.19-1
R58	MF, 1/4W, 1%, 6.19Ω	110-6.19-1
R59	MF, 1/4W, 1%, 6.19Ω	110-6.19-1
R60	MF, 1/4W, 1%, 2.15 kΩ	110-2.15k-1
R61	MF, 1/4W, 1%, 12.1 kΩ	110-12.1k-1
R63	MF, 1/4W, 1%, 10 kΩ	110-10k-1
R64	MF, 1/4W, 1%, 10 kΩ	110-10k-1
R65	MF, 1/4W, 1%, 750 kΩ	110-750k-1
R66	MF, 1/4W, 1%, 14.7 kΩ	110-14.7k-1
R67	MF, 1/4W, 1%, 5.11Ω	110-5.11-1
R68	Variable, 15-Turn, 500Ω	157-500
R69	MF, 1/4W, 1%, 2 kΩ	110-2k-1
R70	MF, 1/4W, 1%, 10 kΩ	110-10k-1
R71	MF, 1/4W, 1%, 750 kΩ	110-750k-1
R72	MF, 1/4W, 1%, 14.7 kΩ	110-14.7k-1

R73	MF, 1/4W, 1%, 10 kΩ	110-10k-1
R74	MF, 1/4W, 1%, 10 kΩ	110-10k-1
R75	MF, 1/4W, 1%, 205 kΩ	110-205k-1
R76	MF, 1/4W, 1%, 511Ω	110-511-1
R77	Variable, 1-Turn, 20Ω	156-20
R78	MF, 1/4W, 1%, 2 kΩ	110-2k-1
R79	MF, 1/4W, 1%, 15 kΩ	110-15k-1
R80	MF, 1/4W, 1%, 511Ω	110-511-1
R81	MF, 1/4W, 1%, 511Ω	110-511-1
R82	MF, 1/4W, 1%, 100 kΩ	110-100k-1
R83	MF, 1/4W, 1%, 100 kΩ	110-100k-1
R84	MF, 1/4W, 1%, 5.11 kΩ	110-5.11k-1
R85	MF, 1/4W, 1%, 5.11 kΩ	110-5.11k-1
R86	MF, 1/4W, 1%, 5.11Ω	110-5.11-1

INTEGRATED CIRCUITS

REF. DES.	DESCRIPTION	WILTRON PART NO.
U1	Quad Analog Switch, LF13201	54-20
U2	NAND Gate, 74LS10	54-42
U3	Op Amp, OP05	54-87
U4	Quad Op Amp, TL072	54-53
U5	2k x 8 EPROM	Not Field-Replaceable
U7	Quad Op Amp, TL074	54-132
U8	Quad Ex. OR Gate, 74LS86	54-125
U9	Dual Volt. Comp., LM393	54-158

MISCELLANEOUS

REF. DES.	DESCRIPTION	WILTRON PART NO.
---	Ejector, PC Board	553-96
TP1 thru TP4	Pin, Test Point	706-44
K1	Relay, 2 Form C	690-28
---	Socket, I.C., 24-Pin	553-67

Table 6-20. A10 FM/Attenuator (660-D-8010)

CAPACITORS			DIODES		
REF. DES.	DESCRIPTION	WILTRON PART NO.	REF. DES.	DESCRIPTION	WILTRON PART NO.
C1	Mica, 130 pF	220-130	CR1	Silicon, 1N4446	10-1N4446
C2	Monolithic, .1 μF	230-37	CR2	Silicon, 1N4446	10-1N4446
C3	Monolithic, .1 μF	230-37	CR3	Zener, 3.3V, 0.4W, 1N746A	10-1N746A
C4	Monolithic, .1 μF	230-37	CR4	Zener, 3.3V, 0.4W, 1N746A	10-1N746A
C5	Monolithic, .1 μF	230-37			
C6	Monolithic, .1 μF	230-37			
C7 ¹	Monolithic, .1 μF	230-37			
C8	Mica, 8 pF	220-8			
C9	Tantalum, 25V, 10 μF	250-42			
C10	Tantalum, 25V, 10 μF	250-42			
C11	Ceramic Disc, .001 μF	230-30			
C12	Mica, 8 pF	220-8			
C13	Monolithic, .1 μF	230-37			
C14	Monolithic, .1 μF	230-37			
C15	Mica, 8 pF	220-8			
C16	Mica, 8 pF	220-8			
C17	Tantalum, 25V, 10 μF	250-42			
C18	Tantalum, 25V, 10 μF	250-42			
C19	Tantalum, 25V, 10 μF	250-42			
C20	Tantalum, 25V, 10 μF	250-42			
C21	Monolithic, .1 μF	230-37			
C22	Monolithic, .1 μF	230-37			
C23	Tantalum, 6V, 68 μF	250-58			
C24	Ceramic Disc .01 μF	230-11			
C25	Ceramic Disc .01 μF	230-11			
C26	Mica, 8 pF	220-8			
C27	Tantalum, 25V, 10 μF	250-42			
C28	Tantalum, 25V, 10 μF	250-42			
C29	Ceramic, .0047 μF	230-36			
C30	Mica, 8 pF	220-8			

¹.01 μF, 230-11, 6637A-40 only.

CR5	Silicon, 1N4446	10-1N4446
CR6	Silicon, 1N4446	10-1N4446
CR7	Zener, 3.3V, 0.4W, 1N746A	10-1N746A
CR8	Zener, 3.3V, 0.4W, 1N746A	10-1N746A
CR9	Silicon, 1N4446	10-1N4446
CR10	Silicon, 1N4446	10-1N4446
CR11	Silicon, 1N4446	10-1N4446
CR12	Silicon, 1N4446	10-1N4446
CR13	Silicon, 1N4446	10-1N4446
CR14	Zener, 4.7V, 0.4W, 1N750A	10-11
CR15	Zener, 4.7V, 0.4W, 1N750A	10-11
CR16	Silicon, 1N4446	10-1N4446
CR17	Silicon, 1N4446	10-1N4446
CR18	Silicon, 1N4446	10-1N4446
CR19	Silicon, 1N4446	10-1N4446
CR20	Silicon, 1N4446	10-1N4446
CR21	Silicon, 1N4446	10-1N4446
CR22	Silicon, 1N4446	10-1N4446
CR23	Silicon, 1N4446	10-1N4446
CR24	Silicon, 1N4446	10-1N4446
CR25	Silicon, 1N4446	10-1N4446
CR26	Silicon, 1N4446	10-1N4446
CR27	Silicon, 1N4446	10-1N4446
CR28	Silicon, 1N4446	10-1N4446
CR29	Silicon, 1N4446	10-1N4446
CR30	Silicon, 1N4446	10-1N4446
CR31	Silicon, 1N4446	10-1N4446
CR32	Silicon, 1N4446	10-1N4446

TRANSISTORS

REF. DES.	DESCRIPTION	WILTRON PART NO.
Q1	PNP, 10W, 2N6552	20-3
Q2	NPN, 10W, 2N6555	20-4
Q3	PNP, 10W, 2N6552	20-3
Q4	NPN, 10W, 2N6555	20-4
Q5	NPN, 50W, TIP110	20-22
Q6	PNP, 50W, TIP115	20-23

RESISTORS

REF. DES.	DESCRIPTION	WILTRON PART NO.
R1	MF, 1/4W, 1%, 14.3 kΩ	110-14.3k-1
R2	MF, 1/4W, 1%, 14.3 kΩ	110-14.3k-1
R3	MF, 1/4W, 1%, 100 kΩ	110-100k-1
R4	MF, 1/4W, 1%, 10 kΩ	110-10k-1
R5	MF, 1/4W, 1%, 10 kΩ	110-10k-1
R6	MF, 1/4W, 1%, 1 kΩ	110-1k-1
R7	MF, 1/4W, 1%, 1 kΩ	110-1k-1
R8	MF, 1/4W, 1%, 1 kΩ	110-1k-1
R9	MF, 1/4W, 1%, 1 kΩ	110-1k-1
R10	Variable, 5k, 1-Turn	156-5k
R11	Variable, 5k, 1-Turn	156-5k
R12	Variable, 5k, 1-Turn	156-5k
R13	Variable, 5k, 1-Turn	156-5k
R14	MF, 1/4W, 1%, 7.32 kΩ	110-7.32k-1
R15	MF, 1/4W, 1%, 4.99 kΩ	110-4.99k-1
R16	MF, 1/4W, 1%, 4.99 kΩ	110-4.99k-1
R17	MF, 1/4W, 1%, 100Ω	110-100-1
R18	MF, 1/4W, 1%, 4.99 kΩ	110-4.99k-1

R19	MF, 1/4W, 1%, 4.99 kΩ	110-4.99k-1
R20	MF, 1/4W, 1%, 16.5 kΩ	110-16.5k-1
R21	Not Used	
R22	MF, 1/4W, 1%, 10 kΩ	110-10k-1
R23	MF, 1/4W, 1%, 10 kΩ	110-10k-1
R24	MF, 1/4W, 1%, 100 kΩ	110-100k-1
R25	MF, 1/4W, 1%, 10 kΩ	110-10k-1
R26	MF, 1/4W, 1%, 10 kΩ	110-10k-1
R27	MF, 1/4W, 1%, 8.87 kΩ	110-8.87k-1
R28	MF, 1/4W, 1%, 49.9 kΩ	110-49.9-1
R29	MF, 1/4W, 1%, 2.8 kΩ	110-2.8k-1
R30	MF, 1/4W, 1%, 14.7Ω	110-14.7-1
R31	MF, 1/4W, 1%, 14.7Ω	110-14.7-1
R32	MF, 1/4W, 1%, 14.7Ω	110-14.7-1
R33	MF, 1/4W, 1%, 14.7Ω	110-14.7-1
R34	MF, 1/4W, 1%, 14.7Ω	110-14.7-1
R35	MF, 1/4W, 1%, 14.7Ω	110-14.7-1
R36	MF, 1/4W, 1%, 2.8 kΩ	110-2.8k-1
R37	MF, 1/4W, 1%, 42.2Ω	110-42.2-1
R38	MF, 1/4W, 1%, 42.2Ω	110-42.2-1
R39	MF, 1/4W, 1%, 42.2Ω	110-42.2-1
R40	MF, 1/4W, 1%, 42.2Ω	110-42.2-1
R41	MF, 1/4W, 1%, 10 kΩ	110-10k-1
R42	MF, 1/4W, 1%, 9.76 kΩ	110-9.76k-1
R43	MF, 1/4W, 1%, 3.65 kΩ	110-3.65k-1
R44	MF, 1/4W, 1%, 80.6Ω	110-80.6-1
R45	MF, 1/4W, 1%, 80.6Ω	110-80.6-1
R46	MF, 1/4W, 1%, 34.8Ω	110-34.8-1
R47	MF, 1/4W, 1%, 34.8Ω	110-34.8-1
R48	MF, 1/4W, 1%, 34.8Ω	110-34.8-1
R49	MF, 1/4W, 1%, 34.8Ω	110-34.8-1
R50	MF, 1/4W, 1%, 3.65 kΩ	110-3.65k-1
R51	MF, 1/4W, 1%, 121Ω	110-121-1
R52	MF, 1/4W, 1%, 121Ω	110-121-1
R53	MF, 1/4W, 1%, 121Ω	110-121-1
R54	MF, 1/4W, 1%, 121Ω	110-121-1
R55	MF, 1/4W, 1%, 10 kΩ	110-10k-1
R56	MF, 1/4W, 1%, 10 kΩ	110-10k-1
R57	MF, 1/4W, 1%, 10 kΩ	110-10k-1
R58	MF, 1/4W, 1%, 10 kΩ	110-10k-1
R59	MF, 1/4W, 1%, 10 kΩ	110-10k-1
R60	MF, 1/4W, 1%, 10 kΩ	110-10k-1
R61	Variable, 10k, 1-Turn	156-10k
R62	Variable, 10k, 1-Turn	156-10k
R63	MF, 1/4W, 1%, 46.4 kΩ	110-46.4k-1
R64	MF, 1/4W, 1%, 8.25 kΩ	110-8.25k-1
R65	MF, 1/4W, 1%, 100Ω	110-100-1
R66	MF, 1/4W, 1%, 3.65 kΩ	110-3.65k-1
R67	MF, 1/4W, 1%, 3.65 kΩ	110-3.65k-1
R68	WW, 3W, 5Ω	130-5-3
R69	WW, 3W, 5Ω	130-5-3
R70	WW, 3W, 5Ω	130-5-3
R71	MF, 1/4W, 1%, 10 kΩ	110-10k-1
R72	MF, 1/4W, 1%, 10 kΩ	110-10k-1
R73	MF, 1/4W, 1%, 9.76 kΩ	110-9.76k-1
R74	MF, 1/4W, 1%, 10 kΩ	110-10k-1
R75	MF, 1/4W, 1%, 8.82 kΩ	110-8.82k-1

INTEGRATED CIRCUITS

REF. DES.	DESCRIPTION	WILTRON PART NO.
U1	Quad Exclusive OR 74LS86	54-125
U2	Comparator, LM311H	54-30
U3	Comparator, LM311H	54-30
U4	Op Amp, LF357	50-7
U5	Quad Switch DG201CJ	54-24

U6	Quad Switch DG201CJ	54-24
U7	Op Amp, LF357	50-7
U8	Op Amp, LF357	50-7
U9	Op Amp, LF357	50-7
U10	Op Amp, LF357	50-7
U11	Hex Inverter, 74LS04	54-74LS04
U12	Dual AND Driver, 75451	54-144
U13	Dual AND Driver, 75451	54-144
U14	Dual AND Driver, 75451	54-144
U15	Dual AND Driver, 75451	54-144

<u>MISCELLANEOUS</u>		
REF. DES.	DESCRIPTION	WILTRON PART NO.
TP1 thru TP6	Pin, Test Point	706-44
---	Heatsink, Transistor #6030	553-53
---	Ejector, P.C. Board	553-96

Table 6-21. All Front Panel (660-D-8011)

<u>CAPACITORS</u>		
REF. DES.	DESCRIPTION	WILTRON PART NO.
C1	Electrolytic, 250 μ F, 25V	250-53
C2	Monolithic, 0.1 μ F, 50V	230-37
C3	Monolithic, 0.1 μ F, 50V	230-37
C4	Monolithic, 0.1 μ F, 50V	230-37
C5	Monolithic, 0.1 μ F, 50V	230-37
C6	Monolithic, 0.1 μ F, 50V	230-37
C7	Monolithic, 0.1 μ F, 50V	230-37
C8	Monolithic, 0.1 μ F, 50V	230-37

<u>DIODES</u>		
REF. DES.	DESCRIPTION	WILTRON PART NO.
DS1	Light Emitting, Red	15-5
DS2	Light Emitting, Red	15-5
DS3	Light Emitting, Red	15-5
DS4	Light Emitting, Red	15-5
DS5	Light Emitting, Red	15-5
DS6	Light Emitting, Red	15-5
DS7	Light Emitting, Red	15-5
DS8	Light Emitting, Red	15-5
DS9	Not Used	
DS10	Light Emitting, Red	15-5
DS11	Light Emitting, Red	15-5
DS12	Not Used	
DS13	Light Emitting, Red	15-5
DS14	Not Used	
DS15	Not Used	
DS16	Light Emitting, Yellow	15-7
DS17	Not Used	
DS18	Light Emitting, Red	15-5
DS19	Light Emitting, Yellow	15-7
DS20	Light Emitting, Yellow	15-7
DS21	Light Emitting, Yellow	15-7
DS22	Light Emitting, Yellow	15-7
DS23	Light Emitting, Yellow	15-7
DS24	Light Emitting, Yellow	15-7
DS25	Light Emitting, Yellow	15-7
DS26	Light Emitting, Yellow	15-7
DS27	Light Emitting, Yellow	15-7
DS28	Light Emitting, Yellow	15-7
DS29	Light Emitting, Yellow	15-7
DS30	Light Emitting, Yellow	15-7
DS31	Light Emitting, Yellow	15-7
DS32	Light Emitting, Yellow	15-7
DS33	Light Emitting, Yellow	15-7
DS34	Not Used	
DS35	Light Emitting, Red	15-5
DS36	Light Emitting, Yellow	15-7

<u>CONNECTORS</u>		
REF. DES.	DESCRIPTION	WILTRON PART NO.
J1	20 Pin, SIP, Female	551-173
J2	20 Pin, SIP, Female	551-173
J3	20 Pin, SIP, Female	551-173
J4	20 Pin, SIP, Female	551-173

<u>TRANSISTORS</u>		
REF. DES.	DESCRIPTION	WILTRON PART NO.
Q1	PNP, 2N2907	20-2N2907
Q2	PNP, 2N2907	20-2N2907

Q3	PNP, 2N2907	20-2N2907
Q4	PNP, 2N2907	20-2N2907
Q5	PNP, 2N2907	20-2N2907
Q6	PNP, 2N2907	20-2N2907
Q7	PNP, 2N2907	20-2N2907
Q8	PNP, 2N2907	20-2N2907
Q9	PNP, 2N2907	20-2N2907
Q10	PNP, 2N2907	20-2N2907
Q11	PNP, 2N2907	20-2N2907
Q12	PNP, 2N2907	20-2N2907
Q13	PNP, 2N2907	20-2N2907
Q14	PNP, 2N2907	20-2N2907
Q15	PNP, 2N2907	20-2N2907

RESISTORS

REF. DES.	DESCRIPTION	WILTRON PART NO.
R1	MF, 1/4W, 1%, 215Ω	110-215-1
R2	MF, 1/4W, 1%, 215Ω	110-215-1
R3	MF, 1/4W, 1%, 215Ω	110-215-1
R4	Not Used	
R5	MF, 1/4W, 1%, 215Ω	110-215-1
R6	MF, 1/4W, 1%, 215Ω	110-215-1
R7	MF, 1/4W, 1%, 215Ω	110-215-1
R8	Not Used	
R9	MF, 1/4W, 1%, 215Ω	110-215-1
R10	MF, 1/4W, 1%, 215Ω	110-215-1
R11	MF, 1/4W, 1%, 215Ω	110-215-1
R12	MF, 1/4W, 1%, 215Ω	110-215-1
R13	MF, 1/4W, 1%, 215Ω	110-215-1
R14	MF, 1/4W, 1%, 215Ω	110-215-1
R15	MF, 1/4W, 1%, 215Ω	110-215-1
R16	MF, 1/4W, 1%, 215Ω	110-215-1
R17	MF, 1/4W, 1%, 215Ω	110-215-1
R18	MF, 1/4W, 1%, 215Ω	110-215-1
R19	Not Used	
R20	MF, 1/4W, 1%, 215Ω	110-215-1
R21	MF, 1/4W, 1%, 215Ω	110-215-1
R22	MF, 1/4W, 1%, 215Ω	110-215-1
R23	MF, 1/4W, 1%, 215Ω	110-215-1
R24	MF, 1/4W, 1%, 147Ω	110-147-1
R25	MF, 1/4W, 1%, 147Ω	110-147-1
R26	MF, 1/4W, 1%, 147Ω	110-147-1
R27	MF, 1/4W, 1%, 147Ω	110-147-1
R28	MF, 1/4W, 1%, 147Ω	110-147-1
R29	MF, 1/4W, 1%, 147Ω	110-147-1
R30	MF, 1/4W, 1%, 147Ω	110-147-1
R31	MF, 1/4W, 1%, 147Ω	110-147-1
R32	MF, 1/4W, 1%, 215Ω	110-215-1
R33	MF, 1/4W, 1%, 4.64k	110-4.64k-1
R34	MF, 1/4W, 1%, 215Ω	110-215-1
R35	MF, 1/4W, 1%, 215Ω	110-215-1
R36	MF, 1/4W, 1%, 215Ω	110-215-1
R37	MF, 1/4W, 1%, 215Ω	110-215-1
R38	MF, 1/4W, 1%, 10k	110-10k-1
R39	Not Used	
R40	Variable, 20k	146-3
R41	Variable, 20k	146-3
R42	Not Used	
R43	Variable, 20k	146-5
RP1	DIP, 56Ω	123-11
RP2	DIP, 220Ω	123-12
RP3	DIP, 220Ω	123-12
RP4	DIP, 220Ω	123-13
RP5	SIP, 220Ω	123-14
RP6	SIP, 220Ω	123-14
RP7	SIP, 4.7k	123-15
RP8	SIP, 4.7k	123-15

SWITCHES

REF. DES.	DESCRIPTION	WILTRON PART NO.
S1	SPST, Momentary	430-130
S2	SPST, Momentary	430-130
S3	SPST, Momentary	430-130
S4	SPST, Momentary	430-130
S5	SPST, Momentary	430-130
S6	SPST, Momentary	430-130
S7	SPST, Momentary	430-130
S8	SPST, Momentary	430-130
S9	SPST, Momentary	430-130
S10	SPST, Momentary	430-130
S11	SPST, Momentary	430-130
S12	SPST, Momentary	430-130
S13	DPST, Momentary	430-131
S14	DPST, Momentary	430-131
S15	SPST, Momentary	430-130
S16	SPST, Momentary	430-130
S17	DPST, Momentary	430-131
S18	SPST, Momentary	430-130
S19	SPST, Momentary	430-130
S20	Not Used	
S21	Not Used	
S22	SPST, Momentary	430-130
S23	SPST, Momentary	430-130
S24	SPST, Momentary	430-130
S25	SPST, Momentary	430-130
S26	Not Used	
S27	SPST, Momentary	430-130
S28	SPST, Momentary	430-130
S29	SPST, Momentary	430-130
S30	SPST, Momentary	430-130
S31	SPST, Momentary	430-130
S32	SPST, Momentary	430-130
S33	SPST, Momentary	430-130
S34	SPST, Momentary	430-130
S35	SPST, Momentary	430-130
S36	SPST, Momentary	430-130
S37	DPST, Momentary	430-131
S38	DPST, Momentary	430-131
S39	SPST, Momentary	430-130
S40	Not Used	
S41	Not Used	
S42	SPST, Momentary	430-130
S43	SPST, Momentary	430-130
S44	SPST, Momentary	430-130
S45	SPST, Momentary	430-130
S46	SPST, Momentary	430-130
S47	SPST, Momentary	430-130
S48	SPST, Momentary	430-130
S49	SPST, Momentary	430-130
S50	SPST, Momentary	430-130
S51	SPST, Momentary	430-130
S52	SPST, Momentary	430-130
S53	SPST, Momentary	430-130
S54	DPST, Momentary	430-131
S55	SPST, Momentary	430-130
S56	SPST, Momentary	430-130
S57	SPST, Momentary	430-130
S58	SPST, Momentary	430-130

INTEGRATED CIRCUITS

REF. DES.	DESCRIPTION	WILTRON PART NO.
U1	74LS374, Octal Latch	54-41
U2	74LS374, Octal Latch	54-41

R41	MF, 1/4W, 1%, 20k	110-20k-1
R42	MF, 1/4W, 1%, 20k	110-20k-1
R43	MF, 1/4W, 1%, 31.6k	110-31.6k-1
R44	MF, 1/4W, 1%, 100k	110-100k-1
R45	MF, 1/4W, 1%, 20k	110-20k-1
R46	Variable, Single-Turn, 10k	156-10k
R47	MF, 1/4W, 1%, 20k	110-20k-1
R48	MF, 1/4W, 1%, 100Ω	110-100-1
R49	MF, 1/4W, 1%, 10 kΩ	110-10k-1
R50	MF, 1/4W, 1%, 10 kΩ	110-10k-1
R51	MF, 1/4W, 1%, 1k	110-1k-1
R52	MF, 1/4W, 1%, 10 kΩ	110-10k-1
RP1	SIP, 10k	123-6
RP2	DIP, 100k	123-10

INTEGRATED CIRCUITS

REF. DES.	DESCRIPTION	WILTRON PART NO.
U1	Micropower Comparator	54-151
U2	8085A, Microprocessor	54-93
U3	74LS373, Octal Latch	54-103
U4	74LS138, Decoder	54-74LS138
U5	2716, 2k x 8 EPROM	Contact
U6	2716, 2k x 8 EPROM	WILTRON
U7	2716, 2k x 8 EPROM	Customer
U8	2716, 2k x 8 EPROM	Service
U9	Not Used	
U10	74LS244, Octal Tri-state Driver	54-143
U11	5101L-1, 256x4 CMOS RAM	54-146
U12	5101L-1, 256x4 CMOS RAM	54-146
U13	DP8304B, Bidirectional Bus Driver	54-128
U14	DP8304B, Bidirectional Bus Driver	54-128
U15	74LS04, HEX Inverter	54-74LS04
U16	74LS01, Quad NAND Gate	54-74LS01

U17	Not Used	
U18	74LS138, Decoder	54-74LS138
U19	74LS138, Decoder	54-74LS138
U20	74LS138, Decoder	54-74LS138
U21	74LS138, Decoder	54-74LS138
U22	74LS138, Decoder	54-74LS138
U23	74LS138, Decoder	54-74LS138
U24	74LS30, 8-input NAND	54-58
U25	8279-5, Keyboard/Display Interface	54-97
U26	96L02, Dual Monostable	54-96L02
U27	555, Timer	54-555
U28	74LS161, 4-Bit Binary Counter	54-60
U29	74LS374, Octal Latch	54-41
U30	74LS374, Octal Latch	54-41
U31	74LS374, Octal Latch	54-41
U32	74LS04, HEX Inverter	54-74LS04
U33	74LS04, HEX Inverter	54-74LS04
U34	74LS02, Quad 2-Input NOR	54-57
U35	74LS02, Quad 2-Input NOR	54-57
U36	TL072, Dual Op Amp	54-53
U37	5101L-1, 256 x 4 CMOS RAM	54-146
U38	5101L-1, 256 x 4 CMOS RAM	54-146

MISCELLANEOUS

REF. DES.	DESCRIPTION	WILTRON PART NO.
B1	Battery, 2.4V	633-8
S1	Switch, Slide, SPDT	420-14
Y1	Crystal, 6.000 MHz	630-17
----	Socket, 20 Pin DIP	553-98
----	Socket, 24 Pin DIP	553-67
----	Socket, 40 Pin DIP	553-66
TP1 thru TP27	Pin, Test Point	706-44

Table 6-23. A13 Switching Power Supply (660-D-8013)

CAPACITORS		
REF. DES.	DESCRIPTION	WILTRON PART NO.
C1	Monolithic, .1 μF, 50V	230-37
C2	Tantalum, 1 μF, 35V	250-19
C3	Tantalum, 10 μF, 25V	250-42
C4	Monolithic, .1 μF, 50V	230-37
C5	Mylar, 1000 pF, 500V, 5%	227-13
C6	Tantalum, 10 μF, 25V	250-42
C7	Tantalum, 2.2 μF, 20V	250-40
C8	Tantalum, 4.7 μF, 35V	250-39
C9	Mylar, .01 μF, 200V	210-20
C10	Monolithic, .1 μF, 50V	230-37
C11	Mylar, 1000 pF, 500V, 5%	227-13
C12	Monolithic, .1 μF, 50V	230-37
C13	Tantalum, 10 μF, 25V	250-42
C14	Tantalum, 12 μF, 350V	250-85
C15	Tantalum, 12 μF, 350V	250-85
C16	Mica, 470 pF	220-470
C17	Disc., .0027 μF, 100V	230-34
C18	Disc., .0027 μF, 100V	230-34
C19	Tantalum, 6.8 μF, 35V	250-41A
C20	Electrolytic, 150 μF, 25V	250-52
C21	Electrolytic, 150 μF, 25V	250-52
C22	Tantalum, 6.8 μF, 35V	250-41A

C23	Tantalum, 6.8 μF, 35V	250-41A
C24	Disc., .0027 μF, 100V	230-34
C25	Disc., .0027 μF, 100V	230-34
C26	Tantalum, 6.8 μF, 35V	250-41A
C27	Electrolytic, 150 μF, 25V	250-52
C28	Electrolytic, 150 μF, 25V	250-52
C29	Tantalum, 6.8 μF, 35V	250-41A
C30	Tantalum, 6.8 μF, 35V	250-41A
C31	Tantalum, 6.8 μF, 35V	250-41A
C32	Tantalum, 6.8 μF, 35V	250-41A
C33	Electrolytic, 47 μF, 63V	250-51
C34	Disc., .0027 μF, 100V	230-34
C35	Tantalum, 6.8 μF, 35V	250-41A
C36	Disc., .002 μF, 500V	230-33
C37	Disc., .002 μF, 500V	230-33
C38	Tantalum, 6.8 μF, 35V	250-41A
C39	Mylar, .1 μF, 250V	210-30
C40	Electrolytic, 47 μF, 63V	250-51
C41	Tantalum, 6.8 μF, 35V	250-41A
C42	Disc., .002 μF, 500V	230-33
C43	Disc., .002 μF, 500V	230-33
C44	Tantalum, 6.8 μF, 35V	250-41A
C45	Mylar, .1 μF, 250V	210-30
C46	Electrolytic, 47 μF, 63V	250-51
C47	Tantalum, 6.8 μF, 35V	250-41A
C48	Monolithic, .1 μF, 50V	230-37
C49	Mica, 15 pF	220-15

C50	Disc, Ceramic, .01 μ F, 1kV	230-40
C51	Disc, Ceramic, .01 μ F, 1kV	230-40
C52	Tantalum, .0047 μ F, 3kV	250-97
C53	Tantalum, .0047 μ F, 3kV	250-97

DIODES

REF. DES.	DESCRIPTION	WILTRON PART NO.
CR1	Silicon, 1N4446	10-1N4446
CR2	Silicon, 1N4446	10-1N4446
CR3	Silicon, 1N4446	10-1N4446
CR4	Silicon, 1N4446	10-1N4446
CR5	Silicon, 1N4446	10-1N4446
CR6	Silicon, 1N4446	10-1N4446
CR7	Silicon, 1N4446	10-1N4446
CR8	Silicon, 1N4446	10-1N4446
CR9	Zener, 15V, 1W, 5%, 1N4744A	10-1N4744A
CR10	Silicon, 1N4446	10-1N4446
CR11	Fast Recovery, 400V, 1A, 1N4936	10-23
CR12	Fast Recovery, 400V, 1A, 1N4936	10-23
CR13	Schottky, 40V, 5A, 1N5825	10-22
CR14	Schottky, 40V, 5A, 1N5825	10-22
CR15	Zener, 25V, 5W, 5%, 1N5360A	10-24
CR16	Fast Recovery, 100V, 3A, MR851	10-27
CR17	Fast Recovery, 100V, 3A, MR851	10-27
CR18	Fast Recovery, 100V, 3A, MR851	10-27
CR19	Fast Recovery, 100V, 3A, MR851	10-27
CR20	Fast Recovery, 200V, 3A, MR852	10-26
CR21	Fast Recovery, 200V, 3A, MR852	10-26
CR22	Fast Recovery, 200V, 3A, MR852	10-26
CR23	Fast Recovery, 200V, 3A, MR852	10-26
CR24	Fast Recovery, 200V, 3A, MR852	10-26
CR25	Fast Recovery, 200V, 3A, MR852	10-26
CR26	Fast Recovery, 400V, 2A, MR854	10-25
CR27	Fast Recovery, 400V, 2A, MR854	10-25
CR28	Fast Recovery, 100V, 1A, 1N4934	10-31
CR29	Fast Recover, 100V, 1A, 1N4934	10-31

INDUCTOR ASSEMBLIES

REF. DES.	DESCRIPTION	WILTRON PART NO.
L1	SPEC-A-8076	310-66
L2	SPEC-A-8077	310-67
L3	SPEC-A-8074	310-64
L4	SPEC-A-8075	310-65
L5	SPEC-A-8076	310-66
L6	SPEC-A-8074	310-64

TRANSISTORS

REF. DES.	DESCRIPTION	WILTRON PART NO.
Q1	PNP, 2N2907	20-2N2907
Q2	NPN, 2N2222A	20-2N2222A
Q3	PNP, MPSA92	20-MPSA92
Q4	PNP, MPSA92	20-MPSA92
Q5	HEXFET, 1 Ω , 350V, 3.5A, 1RF730	20-39
Q6	HEXFET, 1 Ω , 350V, 3.5A, 1RF730	20-39

RESISTORS

REF. DES.	DESCRIPTION	WILTRON PART NO.
R1	MF, 1/4W, 1%, 147 Ω	110-147-1
R2	MF, 1/4W, 1%, 3.16k	110-3.16k-1
R3	MF, 1/4W, 1%, 22.1k	110-22.1k-1
R4	MF, 1/4W, 1%, 2.26k	110-2.26k-1
R5	MF, 1/4W, 1%, 22.1k	110-22.1k-1
R6	Trimmer, 1k	156-1k
R7	MF, 1/4W, 1%, 6.49k	110-6.49k-1
R8	CC, 1/4W, 5%, 22M	101-22M-5
R9	MF, 1/4W, 1%, 42.2k	110-42.2k-1
R10	MF, 1/4W, 1%, 4.53k	110-4.53k-1
R11	MF, 1/4W, 1%, 147 Ω	110-147-1
R12	MF, 1/4W, 1%, 750k	110-750k-1
R13	MF, 1/4W, 1%, 10k	110-10k-1
R14	MF, 1/4W, 1%, 10k	110-10k-1
R15	MF, 1/4W, 1%, 3.32k	110-3.32k-1
R16	MF, 1/4W, 1%, 3.32k	110-3.32k-1
R17	MF, 1/4W, 1%, 499 Ω	110-499-1
R18	MF, 1/4W, 1%, 499 Ω	110-499-1
R19	MF, 1/4W, 1%, 24.9k	110-24.9k-1
R20	MF, 1/4W, 1%, 1.47k	110-1.47k-1
R21	MF, 1/4W, 1%, 10k	110-10k-1
R22	MF, 1/4W, 1%, 100k	110-100k-1
R23	MF, 1/4W, 1%, 14.7k	110-14.7k-1
R24	MF, 1/4W, 1%, 13.3k	110-13.3k-1
R25	MF, 1/4W, 1%, 6.81k	110-6.81k-1
R26	MF, 1/4W, 1%, 8.45k	110-8.45k-1
R27	Trimmer, 5k	156-5k
R28	MF, 1/4W, 1%, 1k	110-1k-1
R29	MF, 1/4W, 1%, 1k	110-1k-1
R30	MF, 1/4W, 1%, 1k	110-1k-1
R31	MF, 1/4W, 1%, 1k	110-1k-1
R32	CC, 1/2W, 5%, 100k	102-100k-5
R33	CC, 1/2W, 5%, 100k	102-100k-5
R34	CC, 1/2W, 5%, 100k	102-100k-5
R35	CC, 2W, 5%, 750 Ω	104-750-5
R36	MF, 1/4W, 1%, 10 Ω	110-10-1
R37	MF, 1/4W, 1%, 10 Ω	110-10-1
R38	MF, 1/4W, 1%, 30.1 Ω	110-30.1-1
R39	MF, 1/4W, 1%, 30.1 Ω	110-30.1-1
R40	CC, 1/2W, 5%, 51 Ω	102-51-5
R41	MF, 1/4W, 1%, 100 Ω	110-100-1
R42	MF, 1/4W, 1%, 100 Ω	110-100-1
R43	CC, 1/2W, 5%, 150 Ω	102-150-5
R44	CC, 1/2W, 5%, 150 Ω	102-150-5
R45	MF, 1/4W, 1%, 100 Ω	110-100-1
R46	MF, 1/4W, 1%, 1k	110-1k-1
R47	CC, 2W, 5%, 750 Ω	104-750-5

<u>TRANSFORMERS</u>		
REF. DES.	DESCRIPTION	WILTRON PART NO.
T1	Driver Transformer Assy SPEC-A-8078	320-56
T2	Driver Transformer Assy SPEC-A-8078	320-56
T3	Output Transformer Assy SPEC-A-8079	320-57
T4	Common-Mode-Isolation	320-70
<u>INTEGRATED CIRCUITS</u>		
REF. DES.	DESCRIPTION	WILTRON PART NO.
U1	Voltage Regulator, 12V, UA7812	54-LM340T-12

U2	Op Amp, LF356H	50-2
U3	Timer, 555NE	54-555
U4	Pulse Width Modulator, MC3420P	54-140

MISCELLANEOUS

REF. DES.	DESCRIPTION	WILTRON PART NO.
TP1 thru TP10	Pins, Test Point	706-44
----	Ejector, P.C. Board	553-96
----	Insulator for Q5 and Q6	790-67

Table 6-24. A14 Motherboard (660-D-8014)

<u>CAPACITORS</u>		
REF. DES.	DESCRIPTION	WILTRON PART NO.
C1	Disc Ceramic, 500V, 0.001 μ F	230-3
C2	Disc Ceramic, 500V, 0.001 μ F	230-3
C3	Disc Ceramic, 500V, 0.001 μ F	230-3
C4	Electrolytic, 35V, 470 μ F	250-87
C5	Disc Ceramic, 1kV, 0.01 μ F	230-40
C6	Disc Ceramic, 1kV, 0.01 μ F	230-40
C7	Disc Ceramic, 1kV, 0.01 μ F	230-40
C8	Disc Ceramic, 1kV, 0.01 μ F	230-40
C9	Disc Ceramic, 1kV, 0.01 μ F	230-40
C10	Disc Ceramic, 1kV, 0.01 μ F	230-40
C11	Disc Ceramic, 1kV, 0.01 μ F	230-40
C12	Electrolytic, 200V, 850 μ F	250-86
C13	Electrolytic, 200V, 850 μ F	250-86
C14	Disc Ceramic, .01 μ F	230-11
C15	Tantalum, 35V, 6.8 μ F	250-41A
C16	Tantalum, 35V, 6.8 μ F	250-41A
C17	Tantalum, 35V, 6.8 μ F	250-41A
C18	Electrolytic, 63V, 10 μ F	250-34
C19	Tantalum, 35V, 6.8 μ F	250-41A
C20	Tantalum, 35V, 6.8 μ F	250-41A
C21	Electrolytic, 63V, 47 μ F	250-51
C22	Electrolytic, 25V, 100 μ F	250-50
C23	Tantalum, 25V, 10 μ F	250-42
C24	Tantalum, 25V, 10 μ F	250-42
C25	Tantalum, 25V, 10 μ F	250-42
C26	Tantalum, 35V, 1 μ F	250-19
C27	Mylar, 250V, 0.1 μ F	210-30
C28	Mica, 560pF	223-560
C29	Mica, 560pF	223-560
C30	Mica, 560pF	223-560
C31	Mica, 560pF	223-560
C32	Disc Ceramic, .01 μ F	230-11
C33	Monolithic, 100V, 0.1 μ F	230-37
C34	Tantalum, 35V, 6.8 μ F	250-41A
C35	Monolithic, 100V, .1 μ F	230-37
C36	Electrolytic, 63V, 10 μ F	250-34
C37	Tantalum, 1 μ F, 35V	250-19

<u>DIODES AND BRIDGE RECTIFIER</u>		
REF. DES.	DESCRIPTION	WILTRON PART NO.
CR1	Zener, 18V, 0.4W	10-1N967B
CR2	Zener, 5.6V, 0.4W	10-1N752A
CR3	Silicon, 1N4446	10-1N4446
CR4	Silicon, 1N4446	10-1N4446
CR5	Silicon Rectifier, SI2	10SI2
CR6	Silicon Rectifier, SI2	10-SI2
CR7	Silicon Rectifier, SI2	10-SI2
CR8	Silicon Rectifier, SI2	10-SI2
CR9	Silicon Rectifier, SI2	10-SI2
CR10	Silicon Rectifier, SI2	10-SI2
CR11	Silicon Rectifier, SI2	10-SI2
CR12	Bridge Rectifier	60-13
CR13	Silicon, 1N4446	10-1N4446
CR14	Zener, 4.7V, 0.4W	10-11
CR15	Silicon Rectifier, SI2	10-SI2
CR16	Silicon Rectifier, SI2	10-SI2
CR17	Silicon, 1N4446	10-1N4446
CR18	Silicon, 1N4446	10-1N4446
CR19	Silicon, 1N4446	10-1N4446
CR20	Silicon, 1N4446	10-1N4446
CR21	Silicon Rectifier, SI2	10-SI2
CR22	Silicon, 1N4446	10-1N4446
CR23	Silicon Rectifier, SI2	10-SI2
CR24	Silicon Rectifier, SI2	10-SI2
CR25	Silicon Rectifier, SI2	10-SI2
CR26	Silicon Rectifier, SI2	10-SI2
CR27	Silicon Rectifier, SI2	10-SI2
CR28	Silicon Rectifier, SI2	10-SI2
CR29	Silicon Rectifier, SI2	10-SI2
CR30	Silicon Rectifier, SI2	10-SI2
CR31	Silicon Rectifier, SI2	10-SI2
CR32	Silicon Rectifier, SI2	10-SI2
CR33	Silicon Rectifier, SI2	10-SI2
CR34	Silicon, 1N4446	10-1N4446
CR35	Silicon, 1N4446	10-1N4446
CR36	Silicon, 1N4446	10-1N4446

Table 6-26. Options and Accessories Parts List

<u>Option 1, Rack Mount</u>		<u>Option 3, GPIB Interface</u>	
NAME	PART NO.		
Left Side Assembly	660-D-8111	A1 GPIB Interface PCB (see Table 6-1)	660-D-8001-3
Right Side Assembly	660-D-8112	A18 GPIB Connector PCB (see Table 6-25; attached to rear panel)	660-B-8018
<u>Option 2, Step Attenuator</u>		<u>Option 11, External Square-Wave Input, Standard (except 6642A)</u>	
Step Attenuator	1010-27	PIN Switch Modulator	1020-17
Cable Assembly, Coupler to Step Attenuator	660-A-8121-1	<u>Option 13, Counted Markers</u>	
Cable Assembly, Attenuator to Rear Panel	660-A-8143-1	BNC Connector, Rear-Panel	510-42
Connector Housing, 9-pin	551-200	<u>Accessories</u>	
		PCB Extender Board	660-D-8062-3

Table 7-1. Service Section Organization

TITLE OF INFORMATION	PAGE	PARAGRAPH
Removal and Installation Procedures	7-1	7-3
Overall Circuit Description	7-8	7-4
Overall Troubleshooting, Description Overall Troubleshooting Flowchart	7-17 7-16	7-5
A12 Microprocessor PCB, Description A12 PCB Schematic A12 PCB Troubleshooting Flowchart	7-17 7-22 7-28	7-6
A11 Front Panel PCB, Description A11 PCB Schematic	7-35 7-39	7-7
A1 GPIB Interface PCB, Description A1 PCB Schematic A1 PCB Troubleshooting Flowchart	7-41 7-45 7-48	7-8
A2 Ramp Generator PCB, Description A2 PCB Schematic A2 PCB Troubleshooting Flowchart	7-55 7-60 7-65	7-9
A3 Marker Generator PCB, Description A3 PCB Schematic A3 Troubleshooting Flowchart	7-67 7-73 7-79	7-10
A4 Automatic Level Control PCB, Description A4 PCB Schematic A4 PCB Troubleshooting Flowchart	7-83 7-86 7-93	7-11
A5 Frequency Instruction and A6-A9 YIG Driver PCBs, Description A5 PCB Schematic A6 PCB Description, Assy. 660-D-8007-3, -5, -7, & -99-91 A6 PCB Description, Assy. 660-D-8007-4 A6 PCB Description, Assy. 660-D-8007-6 A6 PCBs Description, Assy. 660-D-8190 and - 8191 A7-A9 PCBs Description, Assy. 660-D-8008 and -8009, All Dash Numbers A5-A9 PCB Troubleshooting Flowcharts	7-106 7-106 7-115 7-128 7-134 7-140 7-148 7-171	7-12
A10 FM/Attenuator PCB, Description A10 PCB Schematic A10 PCB Troubleshooting Flowchart	7-175 7-178 7-181	7-13
RF Deck, Description Model 6609A RF Deck Block Diagram Model 6617A RF Deck Block Diagram Model 6621A/6621A-40 RF Deck Block Diagram Model 6629A/6629A-40 RF Deck Block Diagram Model 6627A/6637A-40/6638A RF Deck Block Diagram Model 6642A RF Deck Block Diagram Model 6647A/6648A RF Deck Block Diagram Model 6653A RF Deck Block Diagram Model 6659A RF Deck Block Diagram	7-183 7-184 7-184 7-185 7-185 7-185 7-187 7-186 7-188 7-189	7-14
A13/A14 PCBs Switching Power Supply, Description A13/A14 PCB Schematic A14 Motherboard PCB Wire Lists A13/A14 PCBs Troubleshooting Flowcharts A13 PCB Low-Voltage Troubleshooting Procedure	7-190 7-195 7-202 7-229 7-233	7-15
A18 GPIB Connector PCB, Description A18 PCB Schematic	7-230 7-237	7-16

SECTION VII

SERVICE

7-1 INTRODUCTION

This section contains general information, disassembly/reassembly instructions, and service information – circuit descriptions, schematics, parts locator diagrams, and troubleshooting data – for the overall sweep generator and individual printed circuit boards (PCBs). This service information is organized as shown in Table 7-1 (facing page).

7-2 GENERAL INFORMATION

7-2.1 Printed Circuit Board (PCB) Exchange Program

WILTRON has an exchange program that includes most of the 6600A Series PCBs. Upon request, WILTRON will immediately ship a replacement for any sweep generator PCB covered by this program. The customer has 30 days in which to return the defective PCB. Contact Customer Service at 415-969-6500 to make arrangements for an exchange.

7-2.2 Recommended Test Equipment for Troubleshooting

A list of the recommended test equipment for troubleshooting the sweep generator is provided in Table 7-2.

7-3 6600A SERIES PROGRAMMABLE SWEEP GENERATOR, REMOVAL AND REINSTALLATION INSTRUCTIONS

Instructions for the removal and reinstallation or the disassembly and reassembly of certain 6600A Series Sweep Generator components and subassemblies are provided in paragraphs 7-3.1 thru 7-3.5.

7-3.1 Front Panel Assembly, Removal and Reinstallation Instructions

a. Removal.

1. Turn off ac power.
2. Remove the top, bottom, and side covers of the basic frame as follows:
 - (a) Remove the four corner brackets from the rear panel (Figure 7-1).
 - (b) Slide the covers to the rear and remove.
3. Stand the sweep generator on its side, with the RF Deck up.
4. Disconnect the cable connector from A14P37 (Figure 7-2).
5. Using a 3/32-inch hex wrench, remove the four corner and two mid-panel screws securing the front panel assembly to the basic frame (Figure 7-3).
6. Reposition the sweep generator top-side up (sitting on its feet); gently push the front panel assembly away from the front of the basic-frame assembly.
7. Disconnect the ribbon connectors from P5, P6, and P7 on the A12 Microprocessor PCB. Use care to avoid bending the connector pins.

- ###### b. Reinstallation.
- The reinstallation procedure for the front panel assembly is a reversal of the removal procedure.



To prevent chafing, insure that the 3-wire harness going

Table 7-2. Recommended Test Equipment for Troubleshooting

INSTRUMENT	REQUIRED CHARACTERISTICS	RECOMMENDED MANUFACTURER
Digital Multimeter	Dc Voltage: .05% to 30V .002% to 10V.	John Fluke Co. Model 8600A
Oscilloscope	60 MHz bandwidth, 1mV vertical sensitivity, and variable external horizontal input capability.	Tektronix Models 5440/ 5A18/5B10
Scalar Network Analyzer	Ability to display frequency response of sweep generator.	WILTRON Model 560A
RF Detector	Ability to detect signals within the 10 MHz to 26.5 GHz frequency range.	WILTRON Model 7S50, Option 2
Signature Analyzer	Ability to make signature analysis of microprocessor circuitry.	Hewlett-Packard Model 5004A
Directional Coupler	Ability to couple signals within a portion of the 10 MHz to 18 GHz frequency range.	NARDA Model 3202B-10
DC Power Supply	3 volts @ 3 amps	HP 6281
Dual DC Power Supply	1 supply = 0 to 7V 1 supply = +15V Common ground OK.	HP 6236B
DC Power Supply	30V - Isolated from ground and other voltage supplies.	HP 6216

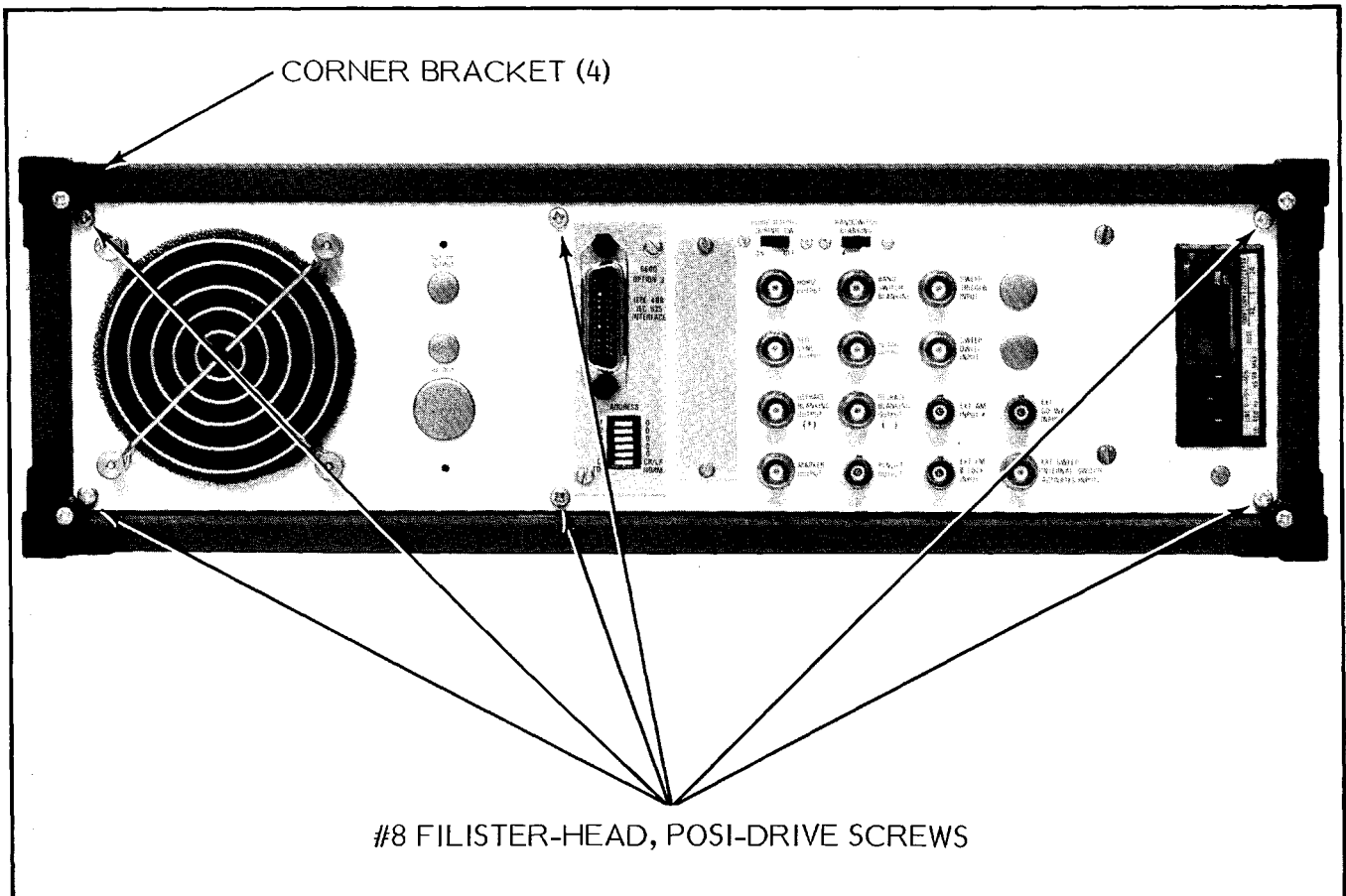

Figure 7-1. 6600A Series Programmable Sweep Generator, Rear Panel

to A12P8 is well clear of the bottom mid-panel screw that secures the front panel assembly to the basic frame.

7-3.2 Front Panel, Disassembly and Reassembly Instructions

a. Disassembly.

1. Remove the front panel assembly from the basic frame; refer to paragraph 7-3.1.

CAUTION

The INCREASE/DECREASE lever extends out approximately 1/4 inch beyond the surfaces of the front panel pushbuttons. Use care to prevent bending the lever shaft.

2. Disconnect the 5-wire connector from A12P4.
3. Disconnect the 3-wire connector from A12P8.

CAUTION

The A12 and A11 PCBs are interconnected using 4 in-line-pin connectors (Figure 7-4). When separating the two PCBs, use care to avoid bending connector pins.

4. Remove the six 1/2-inch 4-40 screws, flatwashers, and lockwashers from the A12 PCB; separate the A12 PCB from the A11 PCB.
5. Remove the knobs from the MANUAL SWEEP, MARKER AMPLITUDE, and EXTERNAL ALC GAIN

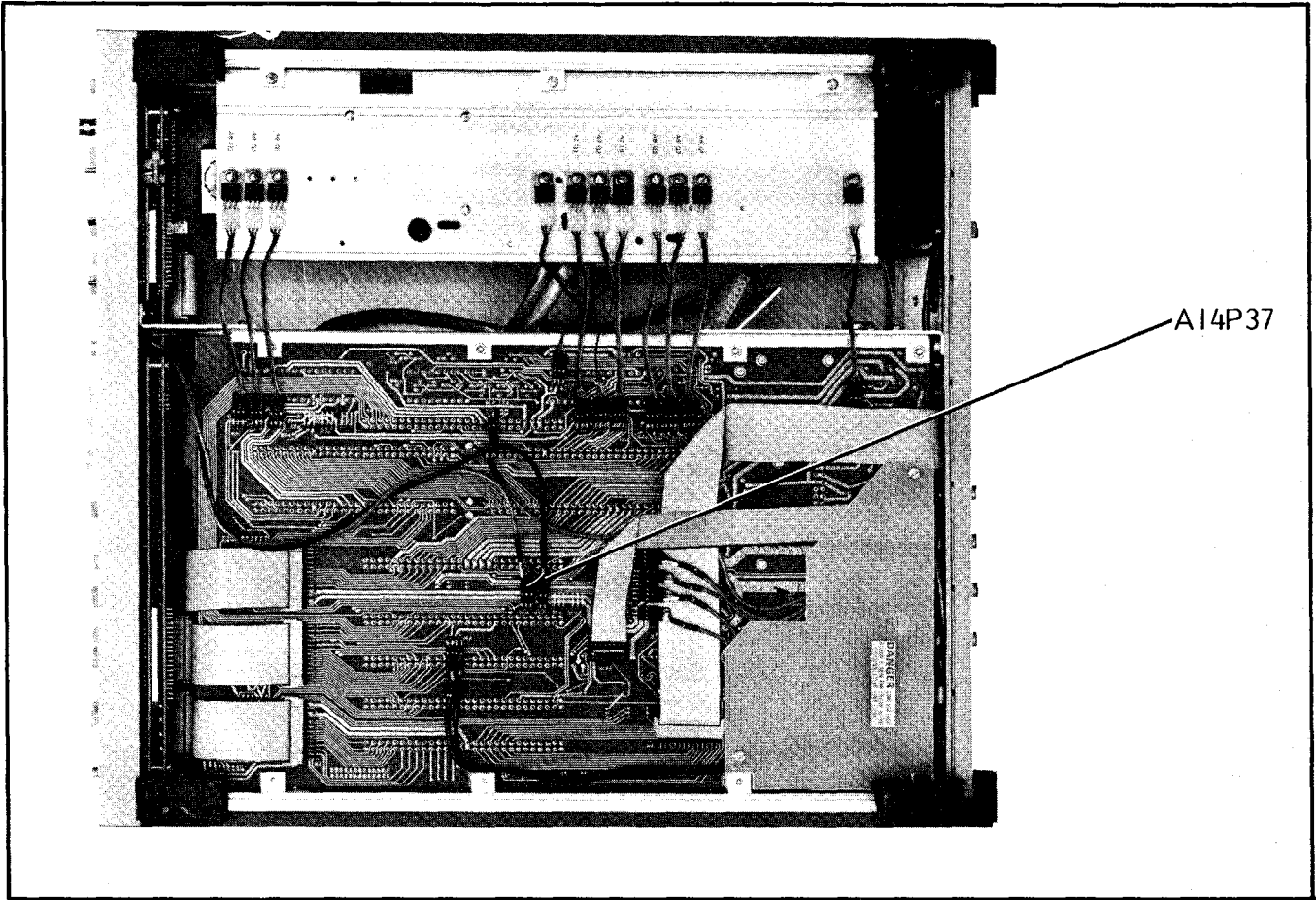

Figure 7-2. 6600A Series Programmable Sweep Generator, Bottom View

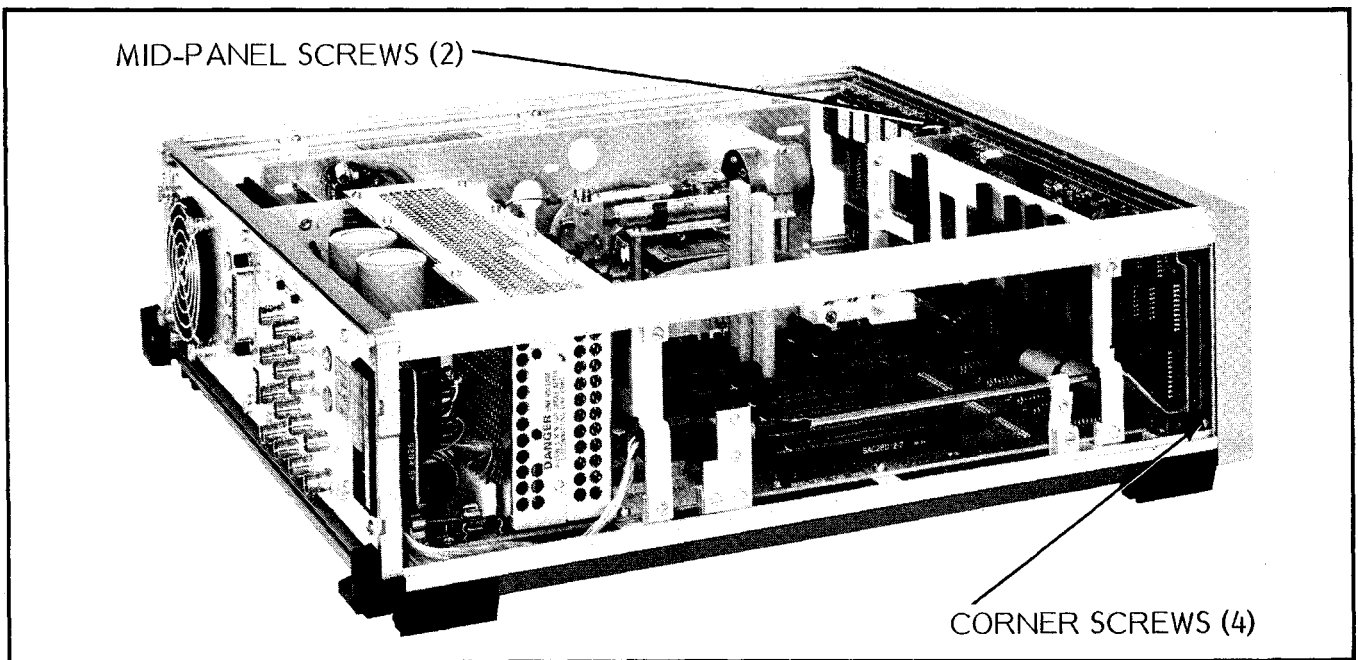

Figure 7-3. 6600A Series Programmable Sweep Generator, Side View

1/2-INCH 4-40 SCREWS, FLATWASHERS, AND LOCKWASHERS

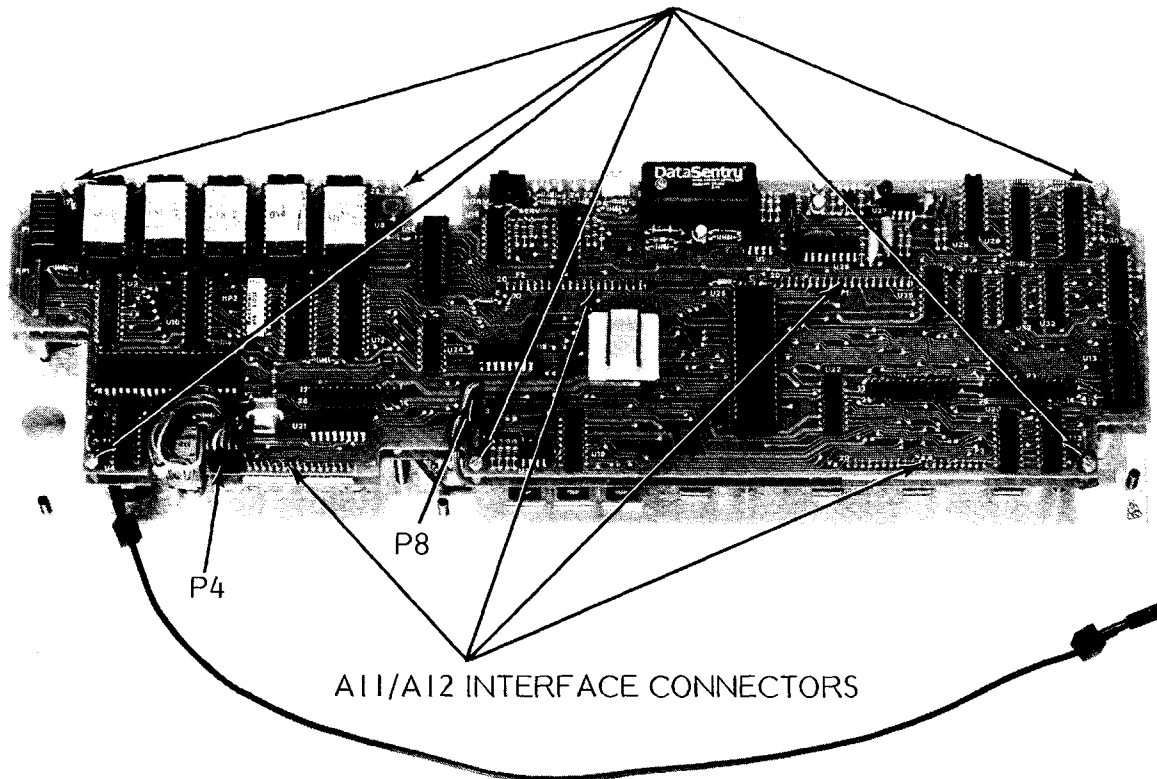

Figure 7-4. 6600A Series Programmable Sweep Generator, Front Panel Assembly

controls. To remove, pull knobs straight off.

6. Remove the eight 7/8-inch 4-40 screws, flatwashers, and lockwashers from the A11 PCB.
7. Separate the A11 PCB from the front panel.

b. Reassembly.

1. Mount the A11 PCB onto the front panel. Use care to insure that the LEDs and pushbuttons are properly aligned with their respective cutouts on the front panel.
2. Reinstall the eight 7/8-inch 4-40 screws, flatwashers, and lockwashers

so that they are snug, but not tight, to the PCB.

3. Check each pushbutton, especially those on the keypad, and insure that none is binding. Reposition the A11 PCB slightly, if required, to prevent pushbutton binding.
4. Tighten the eight A11 retaining screws.
5. Reinstall the knobs on the MANUAL SWEEP, MARKER AMPLITUDE, and EXTERNAL ALC GAIN controls.

NOTE

The knob with the "shoulder" goes on the EXTERNAL ALC GAIN potentiometer.

6. Rejoin the A11 and A12 PCBs, as follows:
 - (a) Position the A12 PCB so that the male pins on P3 and P4 mate with their respective female pins on A11J3 and A11J4. Insure that the pins of A12P1 and A12P2 are aligned with their mating pins on A11J1 and A11J2.
 - (b) While observing the four connectors, gently press the two PCBs together until the connectors are properly seated.
 - (c) Reinstall the six 1/2-inch 4-40 screws, flatwashers, and lockwashers.
7. Reconnect the 5-wire connector to A12P4 (green wire to pin 20); see Figure 7-4.
8. Reconnect the 3-wire connector to A12P8 (brown wire to pin 1); see Figure 7-4.
9. Reinstall the front panel assembly into the basic frame; refer to paragraph 7-3.1.

7-3.3 INCREASE/DECREASE Lever, Switch-Assembly Replacement

The INCREASE/DECREASE lever switch-assembly is not repairable in the field. In the event of an electrical or mechanical failure, the entire switch-assembly must be replaced. To replace this assembly, proceed as follows:

NOTE

The knob on the INCREASE/DECREASE lever is secured to the lever shaft with an epoxy compound. The removal of this knob may cause its destruction. Consequently, when ordering a replacement INCREASE/DECREASE lever switch-assembly, a replacement knob (WILTRON part number 430-106) should be ordered also.

- a. Remove the front panel assembly from the basic frame; refer to paragraph 7-3.1.
- b. Disassemble the front panel assembly; refer to paragraph 7-3.2.
- c. Remove the knob from the INCREASE/DECREASE lever (see NOTE above).
- d. Remove the two 1/4-inch 4-40 screws, flatwashers, and lockwashers, and remove the assembly from the front panel.
- e. Install the new assembly and secure using the 4-40 hardware.
- f. Install new knob on lever shaft, and secure it in place using a quick-drying cement (such as a 3-minute epoxy compound).-
- g. Reassemble the front panel assembly; refer to paragraph 7-3.2.
- h. Reinstall the front panel assembly into basic frame; refer to paragraph 7-3.1.

7-3.4 Rear Panel Assembly, Removal and Reinstallation Instructions

a. Removal.

1. Turn off ac power and disconnect the input line voltage.
2. Remove the top and side covers from the sweep generator as follows:
 - (a) Remove the 4 corner-brackets from the rear panel of the sweep generator, Figure 7-1.
 - (b) Slide the top and side covers to the rear and remove.

WARNING

There are dangerous charged-capacitor voltages present on P1 pins 3 thru 10 when power is removed. Discharge these pins to chassis ground before performing maintenance.

3. Disconnect the Molex connector from A14P1 (Figure 7-5).
4. Remove the six #8 fillister-head, posi-drive screws from the rear panel (Figure 7-1).
5. Gently push the rear panel out from the basic frame and lay it back on the work surface. It is not necessary to remove the rear panel assembly completely; all rear panel components are accessible with the panel in this position.

- b. Reinstallation. The reinstallation procedure for the rear panel assembly is a reversal of the removal procedure.

7-3.5 A13 Switching Power Supply PCB, Removal and Reinstallation

WARNING

Voltages hazardous to life are present through the A13/A14 Switching Power Supply, even when power is turned off and the ac line cord is removed. Before performing maintenance on this power supply, observe the following precautions:

After ac power is turned off and the line cord is removed,

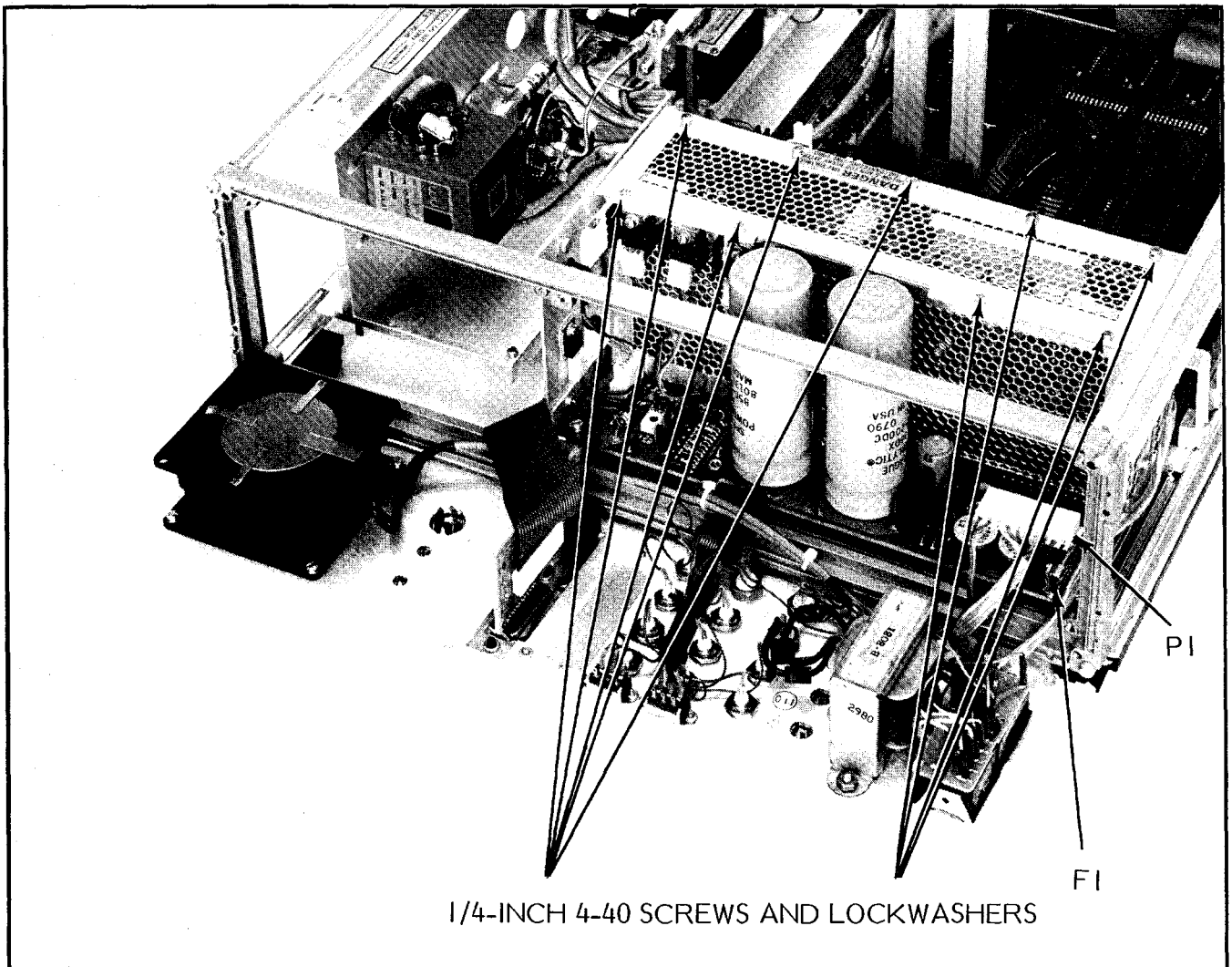

Figure 7-5. 6600A Series Programmable Sweep Generator, Rear Quarter Panels and Assemblies

allow 5 minutes for the capacitor voltages to decay.

Avoid touching the terminals on the 5A FB fuse, A14F1, (Figure 7-5) when power is turned on. +165 Vdc is present on these terminals.

a. Removal.

1. Turn off the ac power and disconnect the ac line cord from the Voltage Selector Module.
2. Remove the top cover from the sweep generator, as follows:
 - (a) Remove the two top, corner brackets from the rear panel of the sweep generator (Figure 7-1).
 - (b) Slide the cover to the rear and remove.
3. Remove the ten 1/4-inch 4-40 screws and lockwashers from the top cover of the A13 card-cage assembly, and remove the cover.
4. Using the ejectors on the ends of the PCB, eject the PCB from the XA13 socket.

- b. Reinstallation. The reinstallation instructions are a reversal of the removal instructions.

NOTE

The A13 PCB power supply switching-frequency is in the RF spectrum (50 kHz). To prevent this RF energy from being radiated, insure that the card-cage cover is securely seated and fastened with all ten screws before the ac power is reapplied.

7-4 6600A SERIES PROGRAMMABLE SWEEP GENERATOR, OVERALL CIRCUIT DESCRIPTION

The 6600A Series Programmable Sweep Generator is a microprocessor-controlled, broad-

band sweeper that uses drop-in (rather than plug-in) radio- and microwave-frequency components. Like most other sweepers, the 6600A is organized into "mainframe" circuits that are universal for all models and frequency components that are model-dependent. For descriptive purposes, the model-dependent circuits are subdivided into five classes: Models 6609A/6617A, Models 6621A/ 6621A-40/ 6629A/ 6629A-40, Models 6637A/ 6637A-40/ 6638A/ 6647A/ 6648A, Models 6653A/6659A, and Model 6642A. Overall block diagrams for the 6609A/6617A, 6637A/6637A-40/6638A/6647A/6648A, and 6653A/6659A are provided in Figures 7-7 thru 7-9 respectively.

- a. Universal Circuits. The 6600A series universal circuits consist of the following printed circuit boards (PCBs): A12 Microprocessor, A11 Front Panel, A1 GPIB Interface (Option 3), A2 Ramp Generator, A3 Marker Generator, A4 Automatic Level Control (ALC), A5 Frequency Instruction, and A10 FM/Attenuator.

The A12 Microprocessor PCB provides overall control for RF signal generation. As shown in Figure 7-7, the A12 PCB interfaces with the Analog Circuits via the μ P Bus, and with the front panel controls via the A11 PCB. The A12 PCB is described in paragraph 7-6.1.

The A11 Front Panel PCB provides an interface for all of the front panel pushbuttons except RESET and SELF TEST. These two pushbuttons are connected directly to the A12, where their activation causes microprocessor interrupt routines to be generated. The A11 PCB is described in paragraph 7-7.1.

The A1 GPIB Interface PCB is only installed for sweep generators containing Option 3. This PCB provides interface between the IEEE-488 Interface Bus (General Purpose Interface Bus--GPIB) and the sweep generator. The A1 PCB is described in paragraph 7-8.1.

The A2 Ramp Generator PCB is the sweep-generation source when either the

TRIGGER-AUTO, -LINE, or -EXT OR SINGLE pushbutton is used to select the triggering mode. These three pushbuttons control the A2 sweep ramp via the μ P BUS. Triggering for the A2 sweep ramp is accomplished via the μ P Bus for the single sweep mode, via the EXT TRIGGER IN line for the external sweep mode, or via the AC LINE VOLTAGE input for the line trigger mode. The remaining two input lines, INTENSITY MARKER and EOB, cause the A2 sweep ramp to dwell momentarily. The INTENSITY MARKER line causes the ramp to dwell when an intensity marker is commanded. And the EOB line causes the ramp to dwell during an oscillator bandswitch (see NOTE). The A2 PCB output lines include the RAMP OUT signal that goes to the A5 PCB and the five signals that go to the rear panel connectors: BANDSWITCH BLANKING (+), (-); RETRACE BLANKING (+), (-); and SEQ SYNC. The A2 PCB is described in paragraph 7-9.1.

NOTE

As shown in Figure 7-8, three YIG oscillators are used to generate a full-band sweep with the Models 6637A/38A/47A/48A. The frequency at which the sweep (or CW tuning) goes from a lower- to a higher-frequency oscillator (or from the heterodyne band to the first oscillator band) is known as the bandswitch point.

The A3 Marker Generator PCB generates the F0, M1, and M2 markers. The marker frequency and mode (VIDEO, RF, INTENSITY) data enters A3 via the μ P BUS. The frequency data is converted to an analog voltage, compared with the RAMP, 0-10V, signal, and used to generate the frequency marker. The mode data selects the type of marker to be displayed: either intensity, RF, or video. The RAMP, 0-10V, signal is also buffered on A3 and supplied to the rear panel HORIZ OUTPUT con-

necter. The A3 PCB, in addition to generating markers, also contains the logic circuitry associated with the front panel INCREASE/DECREASE lever. The MODIFY SIGNAL line provides the input to this logic circuitry. The frequency data generated by this logic circuitry is in the form of an 8-bit digital word. This word is sent to the microprocessor via the μ P Bus. The A3 PCB is described in paragraph 7-10.1.

The A4 Automatic Level Control PCB is the control arm for the RF-output-signal leveling loop. The input arm for the leveling loop is either the built-in Coupler/Detector that is used for internal leveling, or it is the external coupler and detector (or power meter) that is required for external leveling. The output arm of the leveling loop is the PIN switch attenuator current-driver circuit (not shown) located on the A6-A9 YIG Driver PCBs. These current-driver circuits operate the MOD DRIVER 1, 2, 3, and 4 lines used to control Mod and PIN switch attenuation. The A4 also performs the following functions:

1. It sets the magnitude of the RF output power, which the user selects using the front panel LEVEL pushbutton.
2. It creates a "dip" in output power at the RF marker frequency.
3. It provides the RF SLOPE correction to the output power signal.

The A4 PCB, in addition to controlling the leveling loop, provides a latch for the ATTN 1 through ATTN 4 control bits. These control bits come from the microprocessor and go to the A10 PCB. The A4 PCB is described in paragraph 7-11.1.

The A5 Frequency Instruction PCB generates tuning and bandswitch-control voltages for the A6-A9 YIG Driver PCBs. The bandswitch-control voltage is the FCEN/VPF signal, and the tuning voltages are the F CEN, $\Delta F > 50$ MHz, and F CORR signals. There are three sweep-voltage-producing sources in the sweep generator: The A2 PCB, the front panel MANUAL SWEEP potentiometer, and the Step Fre-

quency DAC (digital-to-analog converter, paragraph 3-7.2), located on A5. One of these sources, as determined by the microprocessor, is selected on A5 and used to generate the $\Delta F > 50$ MHz signal. The center frequency, which the user selects using the front panel FREQUENCY RANGE controls, provides the **F CEN** signal. And a correction voltage, which is the sum of the FREQUENCY VERNIER signal from the front panel and the Linearizing ROM signal (see NOTE) from the applicable A6-A9 YIG Driver PCB, provides the **F CORR** signal. The FREQUENCY VERNIER signal enters A5 via the μP Bus, and the linearizing ROM signal enters via the FC (frequency correction) Bus. The A5 PCB also supplies a tuning signal, $\Delta F < 50$ MHz, for the FM coil in the YIG oscillator; this signal goes to the A10 PCB. The $\Delta F < 50$ MHz signal sweeps the YIG oscillator via the FM coil when the sweep width is ≤ 50 MHz. The A5 PCB is described in paragraph 7-12.1.

NOTE

Many YIG oscillators, though inherently linear, often have linearity errors due to magnetic saturation effects. To correct for linearity errors, digital data providing up to ± 64 MHz of frequency correction may be stored in read-only memory (ROM). If required by the installed YIG oscillator, a Linearizing ROM is mounted on the applicable A6, A7, A8, or A9 YIG Driver PCB.

The A10 FM/Attenuator PCB provides a tuning current for the YIG Osc 1-4 FM (frequency modulation) coils and the Osc 1 YIG tracking filter. The tracking filter tuning current is derived from the **TRACK FILTER 1** voltage generated on the A6 PCB. The FM coil tuning current may be derived from either of two sources: an external FM signal from the rear panel via the EXT FM \emptyset LOCK INPUT connector or a sweep width voltage from the A5 PCB via the $\Delta F < 50$ MHz signal

line. In addition to the FM and tracking filter currents, the A10 generates an end-of-band pulse (EOB) whenever a band-switch occurs. The **HET YIG SEL** and **YIG 1, 2, 3** and **4 SEL** lines from the A6-A8 PCBs provide the input for the EOB circuit. The A10 PCB is described in paragraph 7-13.1.

The A14 Motherboard PCB provides an interconnecting plane for the A1 through A10 PCBs. It also provides interconnection via connectors between the A1-A10 PCBs and the A12 PCB, the rear panel connectors, and the RF Deck components. The A14 PCB also contains diagnostic (self-test) and PIN Switch port drive and attenuator circuitry; it also contains part of the switching power supply circuitry. The A14 PCB is described in paragraph 7-15.2.

The A13 Switching Power Supply PCB, in conjunction with the power supply circuits on the A14 PCB, provides power supply voltages for the sweep generator circuits. The A13/A14 Switching Power Supply is described in paragraph 7-15.1.

The A18 GPIB Interface Connector PCB provides a connecting plane for the Option 3 rear panel GPIB connector and address switches. This PCB is installed only on sweep generators containing Option 3. The A18 PCB is described in paragraph 7-16.

- b. Models 6609A/6617A. The model-dependent circuits and components for the 6609A and 6617A consist of the A6 Het/YIG Driver PCB and the components shown on the RF Deck.

The A6 Het/YIG Driver PCB provides tuning and bias currents for the YIG tuning coil. The tuning current is derived from the three tuning voltages (**F CEN**, $\Delta F > 50$ MHz, **F CORR**) supplied by the A5 PCB. The oscillator bias current is generated on the A6 PCB. In addition to tuning and bias currents, the A6 PCB also generates a tracking filter voltage, which is supplied to the A10 PCB. This voltage indirectly provides tuning for the YIG tracking filter that is built into the 6617A

YIG module. The other A6 output is the **HET YIG SEL** line that is supplied to the A10 PCB (6617A). The A6 PCB is described in paragraph 7-12.3.

The RF Deck is a subassembly; it contains all of the sweep generator RF components. This subassembly is described in paragraph 7-14.

- c. Models 6621A/6621A-40/6629A/6629A-40. The model-dependent circuits and components for these four models are as follows (Figure 7-8):

1. The 6621A and 6621A-40 consist of the A6 Het/YIG Driver PCB, A7 YIG Driver PCB, YIG OSC 1, YIG OSC 2, PIN Switch, and Coupler/Detector.
2. The 6629A and 6629A-40 consist of the A7 and A8 YIG Driver PCBs, YIG OSC 2, YIG OSC 3, PIN Switch, and Coupler Detector.

The circuit description for the model-dependent circuits is the same as that for the 6637A/6638A/6647A/6648A circuits in subparagraph d. below.

- d. Models 6637A/6637A-40/6638A/6647A/6648A. The model-dependent circuits and components for these five models consist of the A6, A7, and A8 YIG Driver PCBs, and the components shown on the RF Deck (Figure 7-8).

The A6 Het/YIG Driver and the A7 and A8 YIG Driver PCBs provide tuning and bias currents for the Osc 1, 2, and 3 YIG tuning coils. The tuning currents are derived from the three tuning voltages (**F CEN**, $\Delta F > 50$ MHz, **F CORR**) supplied by the A5 PCB. The oscillator bias currents are generated individually on each A6-A8 PCB. In addition to tuning and bias currents, the A6 PCB also generates a tracking filter voltage, which is supplied to the A10 PCB. This voltage indirectly provides tuning for the YIG tracking filter that is built into the Osc 1 YIG module. With the exception of the MOD DRIVER signals previously described, the other A6-A8 outputs are control lines. The **SNB** and **SNR** lines are select-next-band and select-next-ROM lines, respectively.

When the presently selected oscillator band has reached its upper-most frequency, the **SNB** line selects the next oscillator band and the **SNR** line enables this next oscillator band's linearizing ROM. The **HET YIG SEL** and **YIG 1, 2, and 3 SEL** lines are supplied to the A10 PCB. A detailed overall description of the A6-A8 PCBs is given in paragraph 7-12.2. The A6 PCB is described in paragraph 7-12.3, and the A7 and A8 PCBs are described in paragraph 7-12.4.

The RF Deck is a subassembly; it contains all of the sweep generator RF components. This subassembly is described in paragraph 7-14.

- e. Models 6653A/6659A. The model-dependent circuits and components for the 6653A and 6659A consist of the A6-A9 YIG Driver PCBs and the components shown on the RF Deck (Figure 7-9).

The A6 Het-YIG Driver and A7, A8, and A9 YIG Driver PCBs provide tuning and bias currents for the Osc 1, 2, 3 and 4 YIG tuning coils. The tuning currents are derived from the three tuning voltages (**F CEN**, $\Delta F > 50$ MHz, **F CORR**) supplied by the A5 PCB. The oscillator bias currents are generated individually on the A6-A9 PCBs. In addition to tuning and bias currents, the A6 PCB also generates a tracking filter voltage, which is supplied to the A10 PCB. This voltage indirectly provides tuning for the YIG tracking filter that is built into the Osc 1 YIG module. With the exception of the Mod Driver signals previously described, the other A6-A9 outputs are control lines. The **SNB** and **SNR** lines are select-next-band and select-next-ROM lines, respectively. When the presently-selected oscillator has reached its upper-most frequency, the **SNB** line selects the next oscillator band and the **SNR** line enables this next oscillator band's linearizing ROM. The **HET YIG SEL** and **YIG 1, 2, 3, and 4 FM COIL SEL** lines are supplied to the A10 PCB. An overall description of the A6-A9 PCBs is given in paragraph 7-12.2. The A6 PCB is described in paragraph 7-12.3 and the A7-A9 PCBs are described in paragraph 7-12.4.

The RF Deck is a subassembly; it contains all of the sweep generator RF components. This subassembly is described in paragraph 7-14.

- f. **Model 6642A.** The model-dependent circuits and components for the 6642A consist of the A6 and A7 PCBs and the RF Deck components, as shown in Figure 7-6.

The A6 and A7 YIG Driver PCBs provide tuning and bias currents for the Osc 1 and 2 YIG tuning coils. The tuning currents are derived from the three tuning voltages (**F CEN**, $\Delta F > 50$ MHz, **F CORR**) supplied by the A5 PCB. The oscillator bias currents are generated individually on the A6 and A7 PCBs. With the exception of the MOD DRIVER signals previously de-

scribed, the other A6 and A7 outputs are control lines. The **SNB** and **SNR** lines are select-next-band and select-next-ROM lines, respectively. When the presently-selected oscillator band has reached its upper-most frequency, the **SNB** line selects the next oscillator band and the **SNR** line enables this next oscillator band's linearizing ROM. The **YIG 1, 2, 3,** and **4 SEL** lines are supplied to the A10 PCB. An overall description of the A6/A7 PCBs is given in paragraph 7-12.2. The A6 PCB is described in paragraph 7-12.3 and the A7 PCB is described in paragraph 7-12.4.

The RF Deck is a subassembly; it contains all of the sweep generator RF components. This subassembly is described in paragraph 7-14.

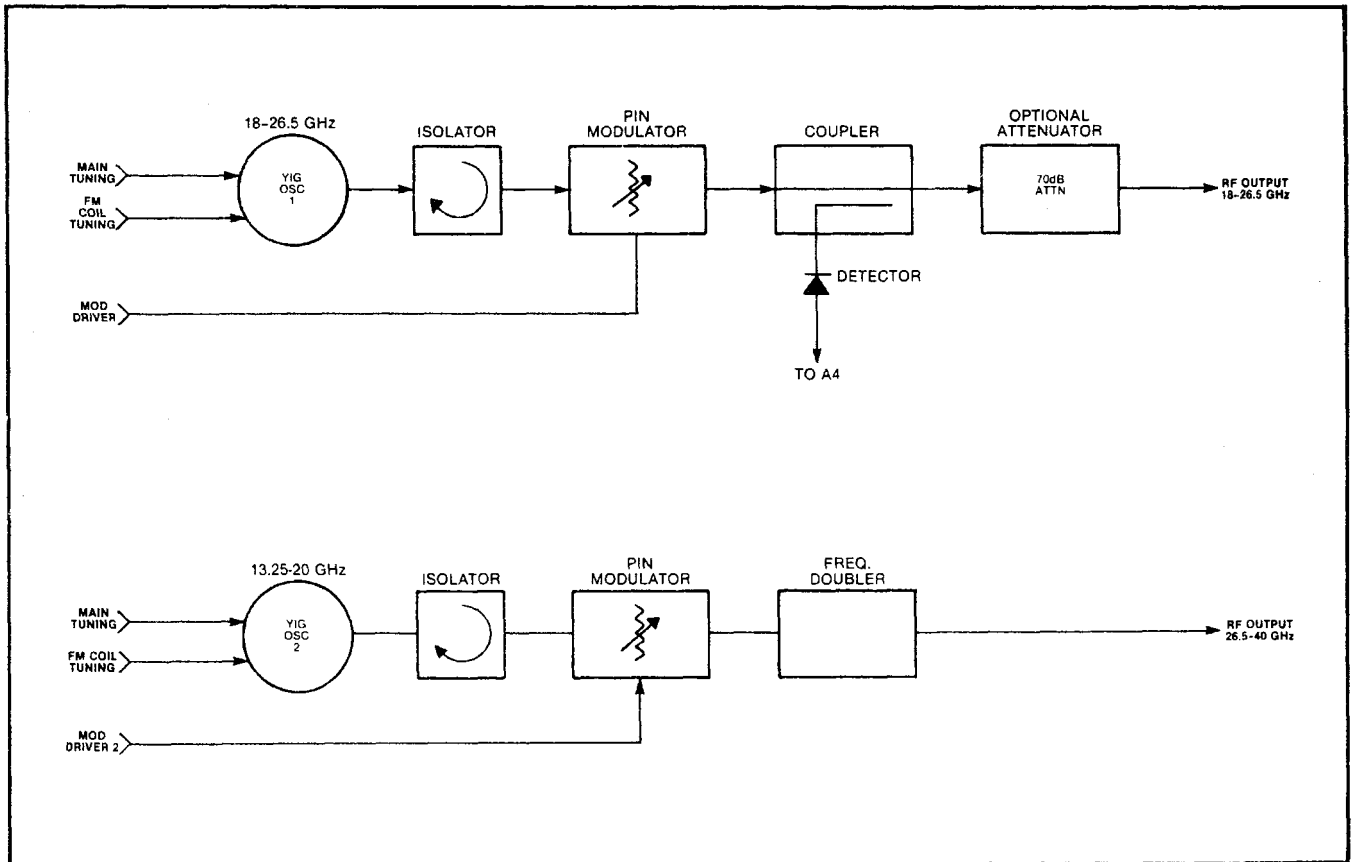
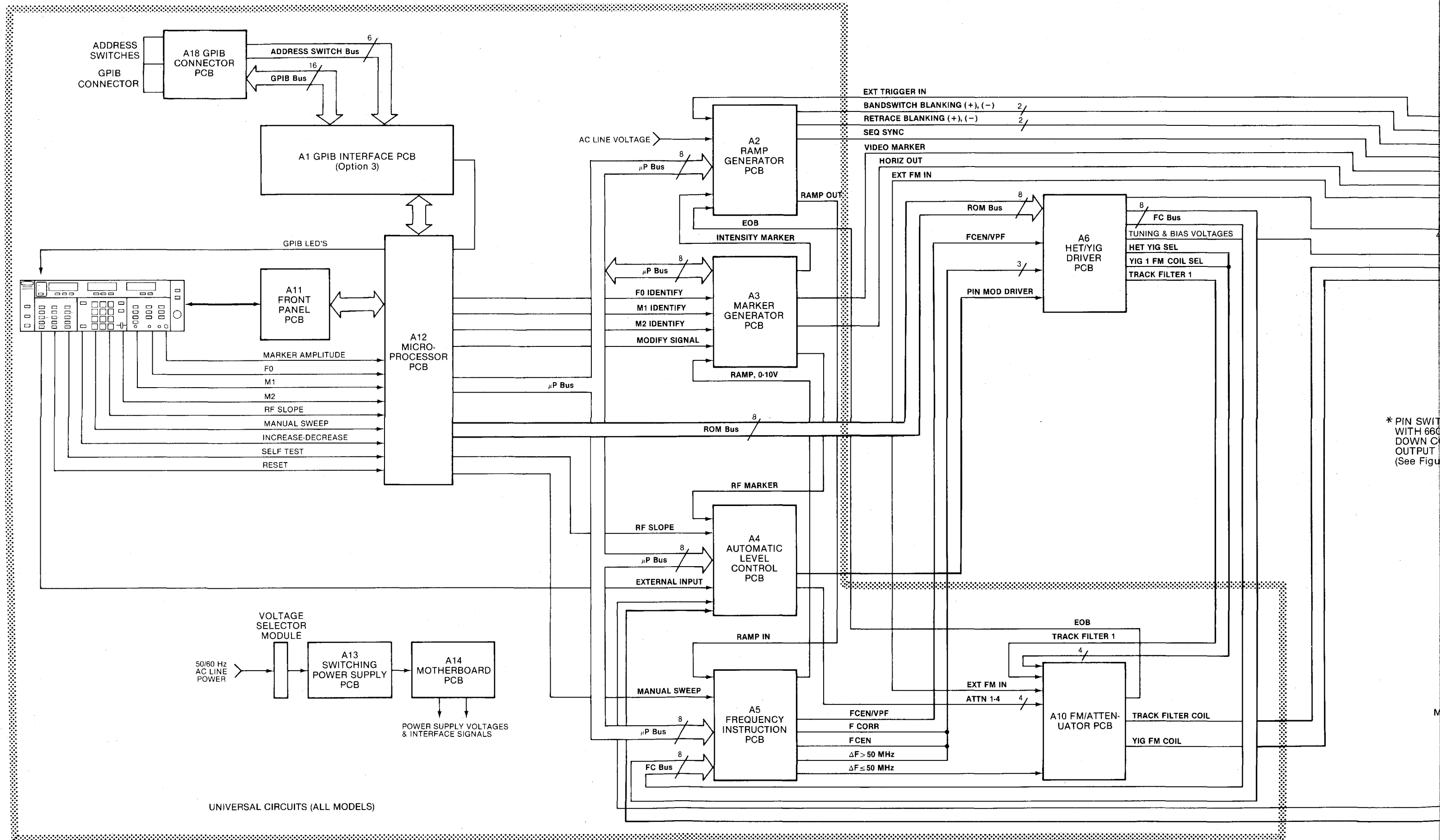

Figure 7-6. Model 6642A RF Components Deck



* PIN SWIT WITH 660 DOWN C OUTPUT (See Fig)

UNIVERSAL CIRCUITS (ALL MODELS)

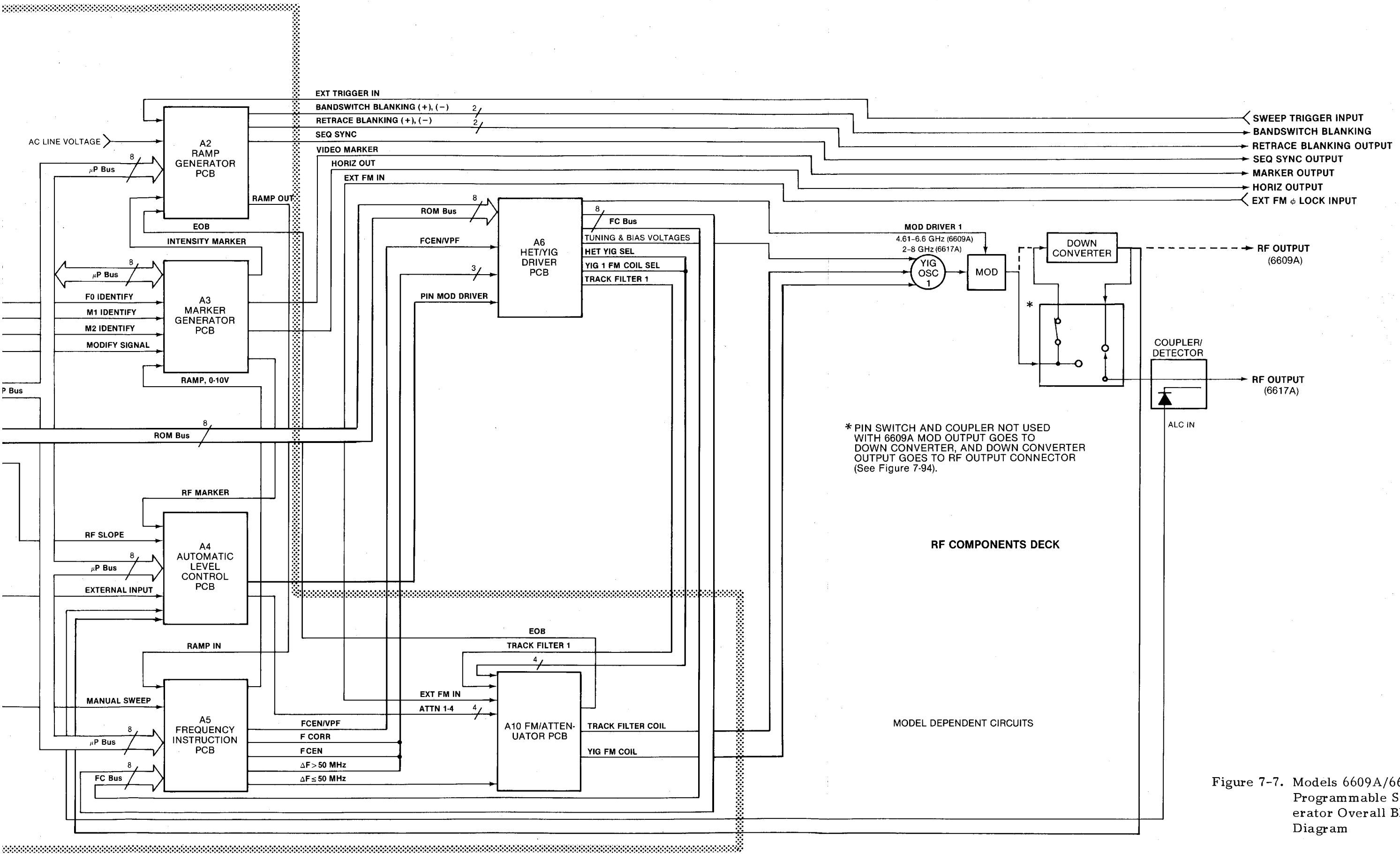
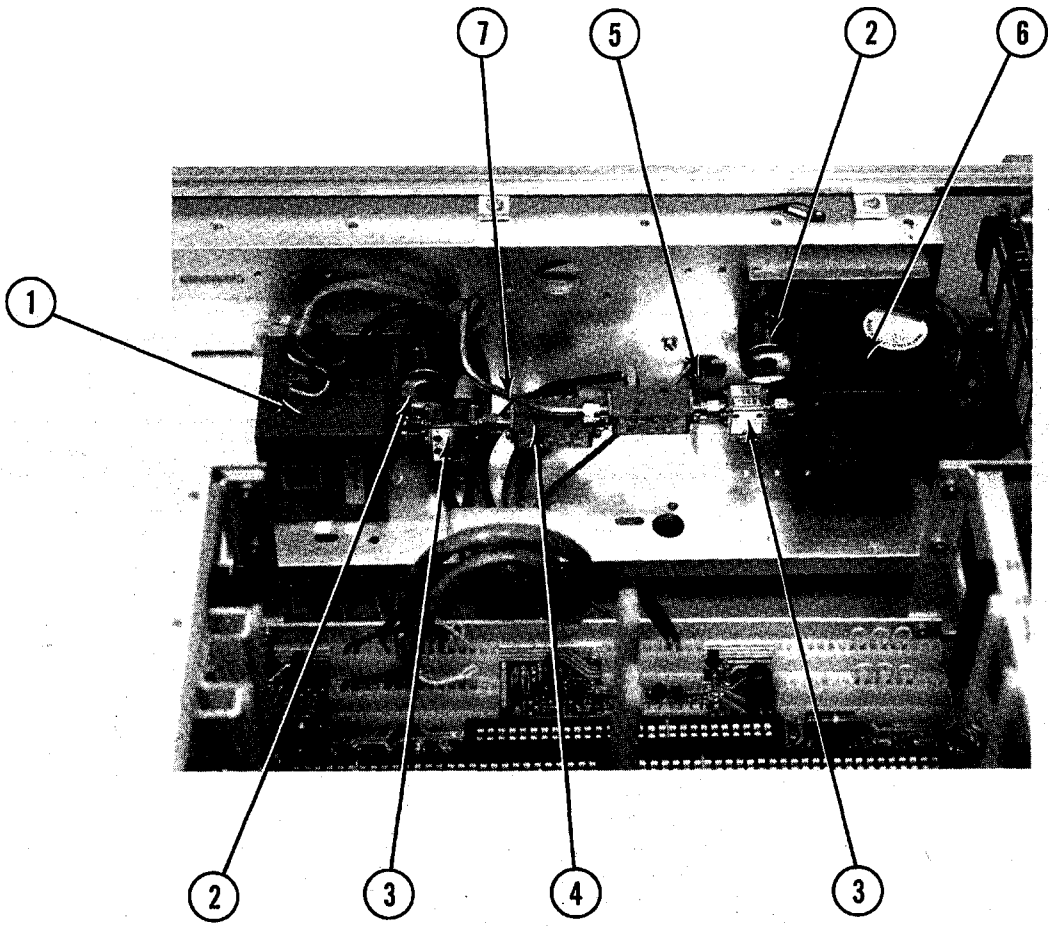
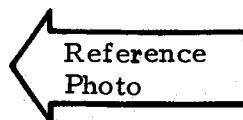

Figure 7-7. Models 6609A/6617A Programmable Sweep Generator Overall Block Diagram



INDEX NO.	NAME	PART NO.
1	YIG Oscillator Assembly, 13.25-20 GHz (Figure 6-9)	SPCL-C-11622
2	Compensation Transformer	320-64
3	Isolator	Figure 6-9
4	PIN Modulator	1020-17
5	Cable Assembly, PIN Mod. to Doubler	660-A-8103-3
6	YIG Oscillator Assembly, 18-26.5 GHz (Figure 6-9)	SPCL-C-11621
7	Cable Assembly, PIN Mod. to Coupler	660-A-8103-5
-	Housing, 10-pin	551-199
-	PIN Modulator Cable Assembly	SPEC-S-6494
-	Cable Clip	721-17
-	Waveguide Assembly	660-A-8166
-	Frequency Doubler	1040-13
-	WSMA Output Assembly	660-D-9371
-	Detector, Model 70	70-A-7453
-	Thermistor	35-4
-	Feed-Thru	702-2
-	Coupler, 18-26.5 GHz	1091-21
-	Coupler Cable Assembly	660-A-9378
-	(VR1) IC, -5V Regulator, μ A7905	54-185
-	Nylon Clamp, 1/2"	720-1/2
-	RF Deck Extrusion	660-D-8115
-	Standoff, 4-40 x 1.75"	785-420
-	Base Plate	790-163
-	Washer	790-164
-	Clamp	790-165
-	(T1) Compensation Transformer	320-64

Figure 6-7. RF Deck Assembly - 6642A



INDEX NO.	NAME	PART NO.
1	Oscillator Assembly, 18-26.5 GHz (Figure 6-9)	660-C-8175-2
2	Isolator	Figure 6-9
3	Down Converter Assembly (6659A)	MEF-D-9157
4	Cable Assembly, Down Converter to PIN Switch J1	CABL-A-9202-24
5	10 dB Pad	1010-28
6	PIN Switch Assembly	660-D-11745-2
7	Cable Assembly, 10 dB Pad to PIN Switch J6	CABL-A-9202-23
8	Oscillator Assembly, 12.4-18 GHz (Figure 6-9)	
	a. Avantek Oscillator	660-C-8085-2
	b. WJ Oscillator	660-C-8085-3
9	Filter	Figure 6-9
10	Cable Assembly, Filter to PIN Switch J2	CABL-A-9203-6
11	Cable Assembly	
	a. Avantek Oscillator to Filter	CABL-A-9201-22
	b. WJ Oscillator to Isolator	CABL-A-9204-5
12	Cable Clip	721-17
13	Matched Modulator Assembly	660-B-9342
14	Oscillator Assembly, 2-8 GHz (Figure 6-9)	660-C-8087-4
15	Transformer, Compensation	
	a. YIG Oscillator 1005-46 or -47	320-66
	b. YIG Oscillator 1005-53 or -54	320-65
	c. YIG Oscillator 1005-55, -59, or -61	320-64
16	Oscillator Assembly, 8-12.4 GHz (Figure 6-9)	
	a. Avantek Oscillator	660-C-8086-6
	b. WJ Oscillator	660-C-8086-7
17	Cable Assembly, Filter to PIN Switch J3	CABL-A-9202-22
-	Transistor, PNP, TIP 117	20-5
-	Voltage Regulator, -5V	54-184

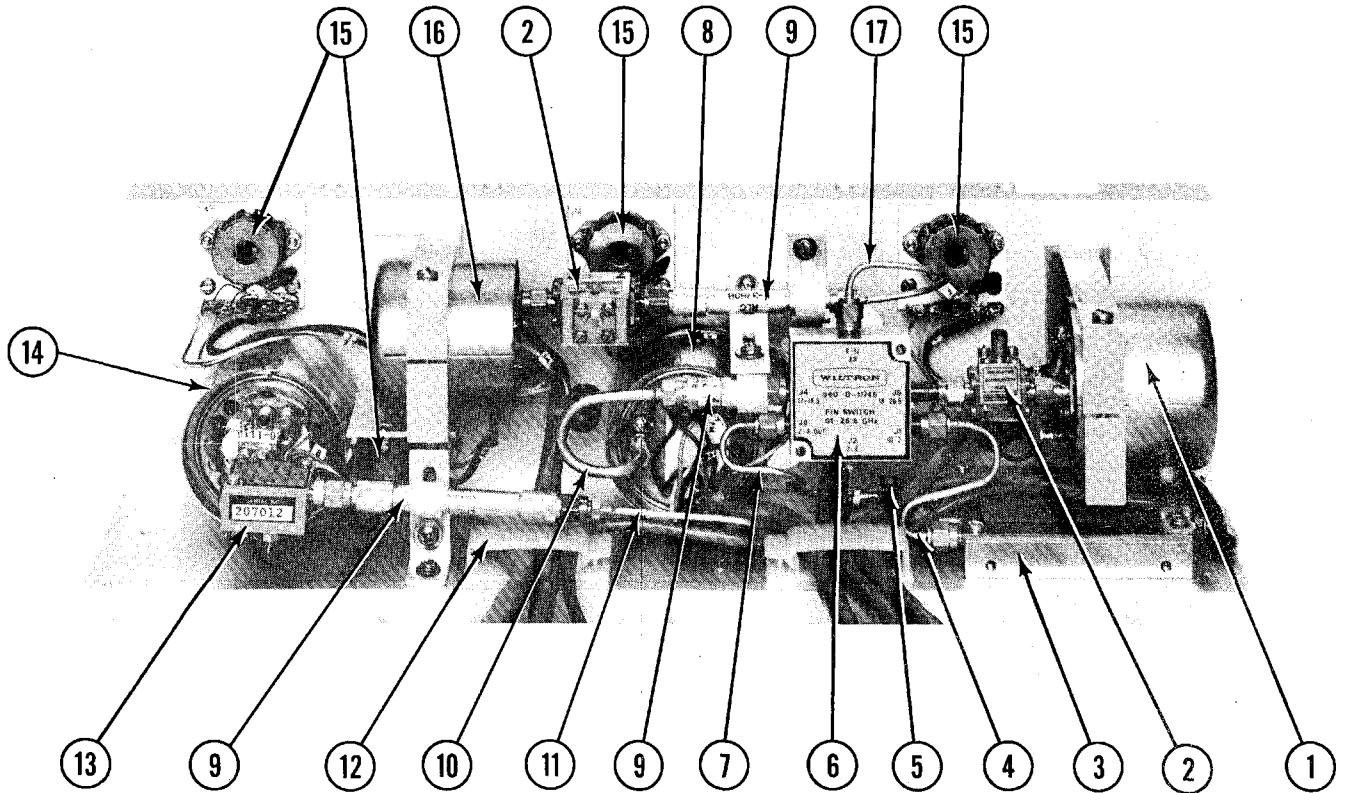
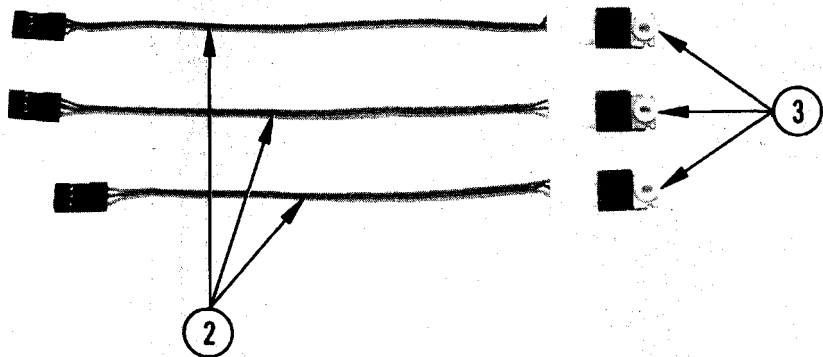
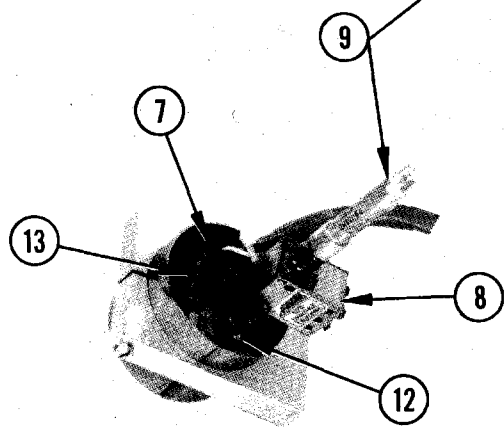
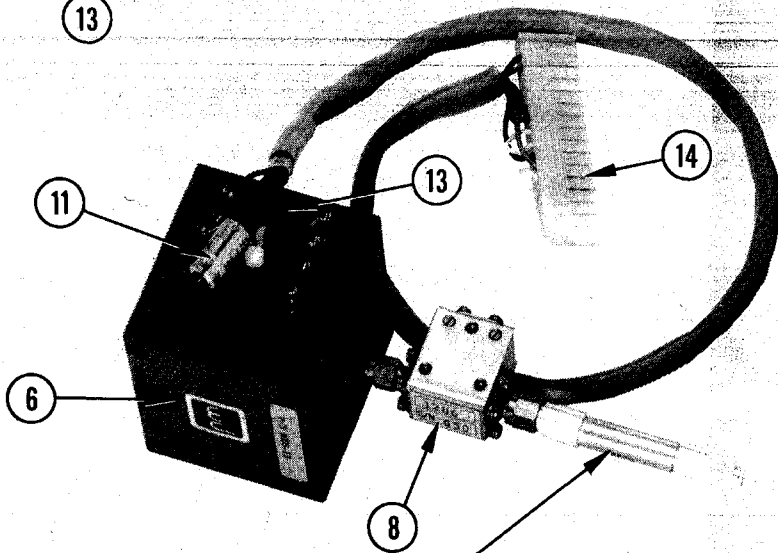
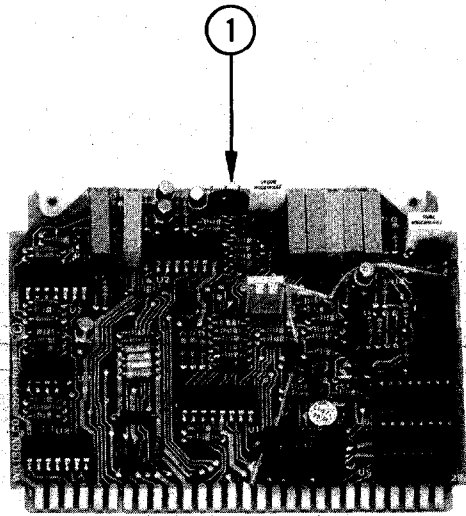
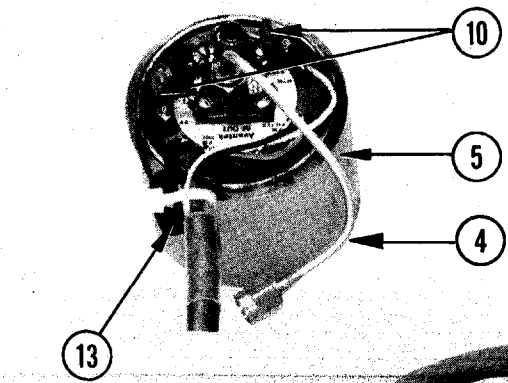

Figure 6-8. RF Deck Assembly - 6653A/6659A



**INDEX
NO.**

NAME

PART NO.

1	PCB Assembly, YIG Driver	
	a. 2-8 GHz (6609A, Table 6-6)	660-D-8007-4
	b. 2-8 GHz (6617A, Table 6-7)	660-D-8007-6
	c. 2-8 GHz (6621A, Table 6-8)	660-D-8007-99-91
	d. 2-8 GHz (6637A/6647A, Table 6-8)	660-D-8007-3
	e. 2-8 GHz (6621A-40, Table 6-9)	660-D-12868-99-91
	f. 2-8 GHz (6637A-40, Table 6-9)	660-D-12868-3
	g. 2-8 GHz (6638A/6648A, Table 6-8)	660-D-8007-5
	h. 2-8 GHz (6653A/6659A Table 6-11)	660-D-8007-7
	i. 8-12.4 GHz	
	(1) Avantek (6621A, Table 6-12)	660-D-8009-99-90
	(2) Avantek (6621A-40, Table 6-13)	660-D-8009-99-91
	(3) Avantek (6629A, Table 6-12)	660-D-8009-99-92
	(4) Avantek (6629A-40, Table 6-13)	660-D-8009-99-93
	(5) Avantek (6637A/6647A, Table 6-12)	660-D-8009-4
	(6) Avantek (6637A-40, Table 6-13)	660-D-8009-14
	(7) Avantek (6638A/6648A, Table 6-12)	660-D-8009-6
	(8) Avantek (6653A/6659A, Table 6-17)	660-D-8009-9
	(9) WJ (6637A/6647A, Table 6-12)	660-D-8009-7
	(10) WJ (6637A-40, Table 6-13)	660-D-8009-17
	(11) WJ (6638A/6648A, Table 6-12)	660-D-8009-8
	(12) WJ (6653A/6659A, Table 6-17)	660-D-8009-12
	j. 12.4-18.6 GHz	
	(1) Avantek (6629A-40, Table 6-14)	660-D-8009-99-94
	(2) Avantek (6637A-40, Table 6-14)	660-D-8009-16
	(3) Avantek (6653A/6659A, Table 6-18)	660-D-8009-10
	(4) WJ (6629A, Table 6-15)	660-D-8008-99-90
	(5) WJ (6637A/6647A, Table 6-15)	660-D-8008-4
	(6) WJ (6637A-40, Table 6-14)	660-D-8009-15
	(7) WJ (6653A/6659A, Table 6-18)	660-D-8009-13
	k. 12.4-20 GHz (6638A/6648A, Table 6-15)	660-D-8008-7
	l. 18.6-26.5 GHz (6653A/6659A, Table 6-19)	660-D-8009-11
	m. 18.6-26.5 GHz (6642A, Table 6-10)	660-D-8190-99-98
	n. 26.5-40 GHz (6642A, Table 6-16)	660-D-8191-99-93
2	Cable, Transistor (3 ea)	660-A-8100
3	Transistors Q1, Q2, Q3;	20-2N6044
	Q1 on 6609A/6617A; .01-18 GHz band	20-2N6041
	of 6637A/6637A-40/6647A/6653A and 6659A; and	
	8-12.4 GHz band of 6637A/6637A-40/6638A/6647A/6648A	
4	Cable, SMA Male-Male, RG085	660-A-8101-5

Figure 6-9. Oscillator Assembly (Sheet 1 of 2)



INDEX NO.	NAME	PART NO.
—	YIG Oscillator, 4.6-6.6 GHz (6609A)	
	a. Avantek	1005-45
	b. WILTRON	1005-C-11236
5	YIG Oscillator, 2-8 GHz (All except 6609A/6642A)	1005-46 or -47
6	YIG Oscillator, WJ	
	a. 8-12.4 GHz (6637A/6637A-40/6638A/6647A/6648A/ 6653A/6659A)	1005-54
	b. 12.4-18.6 GHz (6629A/6637A/6637A-40/6647A/ 6653A/6659A)	1005-51
	c. 12.4-18.0 GHz (6653A/6659A)	1005-55
	d. 12.4-20 GHz (6638A/6648A)	1005-52
	e. 13.25-20 GHz (6642A)	1005-40
7	YIG Oscillator, Avantek	
	a. 8-12.4 GHz (6621A/6621A-40/6629A/6629A-40/ 6637A/6637A-40/6638A/6647A/6648A)	1005-53
	b. 12.4-18.6 GHz (6629A-40/6637A-40/6653A/6659A)	1005-59
	c. 18-26.5 GHz (6642A)	1005-61
8	Isolator	
	a. 4-8 GHz (6621A/6621A-40/6629A/6629A-40/6637A/ 6637A-40/6638A/6647A/6648A/6653A/6659A)	1000-29
	b. 7-12.4 GHz (6621A/6621A-40/6629A/6629A-40/6637A/ 6637A-40/6638A/6647A/6648A/6653A/6659A)	1000-21
	c. 12.4-18.6 GHz (6629A/6629A-40/6637A/6637A-40/ 6647A/6653A/6659A)	1000-20
	d. 12.4-20 GHz (6638A/6648A)	1000-35
9	Low-Pass Filter	
	a. 2-8 GHz (All except 6609A/6642A)	1030-26
	b. 8-12.4 GHz (6621A/6621A-40/6629A/6629A-40/6637A/ 6637A-40/6638A/6647A/6648A/6653A/6659A)	1030-29
	c. 2-18.7 GHz (6629A/6629A-40/6637A/6637A-40/6638A/ 6647A/6648A/6653A/6659A)	1030-31
	d. 12.4-20 GHz (6638A/6648A)	1030-32
10	Capacitor, Tantalum, 10 μ F, 25V	250-42
11	Capacitor	
	a. 8-12.4 GHz Oscillator on 6653A/6659A: 15 μ F	250-25
	b. 8-12.4 GHz Oscillator on all others: 10 μ F	250-42A
	c. 12.4-18 GHz Oscillator on 6653A/6659A: 10 μ F	250-42
	d. 12.4-18 GHz Oscillator on all others: 100 μ F	250-50
12	Capacitor, Tantalum, 10 μ F	250-42
13	Core, Torroid	640-5
14	Connector Housing, 16-pin Female Pin	551-247 551-35
—	Resistor (R1) MF, 1/4W, 1%, 11 Ω	110-11-1
—	Cover (for Item 6 oscillator)	660-B-8160

Figure 6-9. Oscillator Assembly (Sheet 2 of 2)

Table 6-1. A1 GPIB Interface, Option 3 (660-D-8001)

<u>CAPACITORS</u>					
REF. DES.	DESCRIPTION	WILTRON PART NO.	REF. DES.	DESCRIPTION	WILTRON PART NO.
C1	Tantalum, 2.2 μ F, 20V	250-40A	U6	74LS155, Dual 1-of-4 Decoder	54-101
C2	Tantalum, 2.2 μ F, 20V	250-40A	U7	74LS138, 1-of-8 Decoder	54-74LS138
C3	Tantalum, 10 μ F, 25V	250-42	U8	74LS373, Octal Latch	54-103
C4	Monolithic, .1 μ F, 50V	230-37	U9	Not Used	
C5	Monolithic, .1 μ F, 50V	230-37	U10	74LS04, Hex Inverter	54-74LS04
C6	Monolithic, .1 μ F, 50V	230-37	U11	74LS01, Quad Open Collector NAND	54-74LS01
C7	Monolithic, .1 μ F, 50V	230-37	U12	8085A, CPU	54-93
C8	Monolithic, .1 μ F, 50V	230-37	U13	74LS123 one shot	54-116
C9	Monolithic, .1 μ F, 50V	230-37	U14	7474, Dual D Flip-Flop	54-7474
			U15	74LS244, Non-inverting Octal Tri-State Driver	54-143
			U16	74LS244, Non-inverting Octal Tri-State Driver	54-143
			U17	8291 GPIB Listener/Talker	54-124
			U18	MC3447 Motorola GPIB Transreceiver, ceramic pkg., Cs. 623	54-142
			U19	MC3447 Motorola GPIB Transreceiver, ceramic pkg., Cs. 623	54-142
			U20	74LS74, Dual D Flip-Flop	54-44
			U21	74LS74, Dual D Flip-Flop	54-44
			U22	74LS374, Octal Latch	54-41
			U23	74LS112, Dual J-K Flip-Flop	54-74LS112
			U24	74LS374, Octal Latch	54-41
			U25	74LS00, Quad NAND	54-74LS00
			---	Socket, Dip, 18-Pin; U9	551-148
			---	Socket, Dip, 40-Pin; U1, 12, 17	553-66
			---	Socket, Dip, 24-Pin; U4, 5	553-67
			---	Plug, Dip, 18-Pin; U9	551-236
<u>RESISTORS</u>			<u>MISCELLANEOUS</u>		
REF. DES.	DESCRIPTION	WILTRON PART NO.	REF. DES.	DESCRIPTION	WILTRON PART NO.
R1	MF, 1/4W, 1%, 5.11k	110-5.11k-1	Q1	Transistor, 2N4249, PNP	20-2N4249
R2	MF, 1/4W, 1%, 10k	110-10k-1	S1	Switch, Slide, SPDT	420-14
R3	MF, 1/4W, 1%, 10k	110-10k-1	TP1	thru	
R4	MF, 1/4W, 1%, 10k	110-10k-1	TP22	Test Point Pins	706-44
R5	MF, 1/4W, 1%, 10k	110-10k-1	Y1	Crystal, 6.000 MHz	630-17
R6	MF, 1/4W, 1%, 40.2k	110-40.2k-1	---	Ejector, P.C. Board	553-96
R7	MF, 1/4W, 1%, 487 Ω	110-487-1			
R8	MF, 1/4W, 1%, 40.2k	110-40.2k-1			
R9	MF, 1/4W, 1%, 10k	110-10k-1			
RP1	Resistor Network, 10k, 8-Pin, 7-Resistor	123-6			
RP2	Resistor Network, 10k, 8-Pin, 7-Resistor	123-6			
<u>INTEGRATED CIRCUITS, SOCKETS, AND PLUGS</u>					
REF. DES.	DESCRIPTION	WILTRON PART NO.			
U1	8255A, Programmable Interface	54-155			
U2	PD211ALC-4 256 x 4 Static RAM	54-11			
U3	PD211ALC-4 256 x 4 Static RAM	54-11			
U5	2716 2k x 8 EPROM	Contact WILTRON Customer Service			

Table 6-2. A2 Ramp Generator (660-D-8002)

<u>CAPACITORS</u>					
REF. DES.	DESCRIPTION	WILTRON PART NO.	REF. DES.	DESCRIPTION	WILTRON PART NO.
C1	Tantalum, 6V, 68 μ F	250-58	C12	Monolithic, 50V, .01 μ F	250-77
C2	Monolithic, 50V, .1 μ F	230-37	C13	Monolithic, 50V, .1 μ F	230-37
C3	Monolithic, 50V, .1 μ F	230-37	C14	Monolithic, 50V, .1 μ F	230-37
C4	Monolithic, 50V, .1 μ F	230-37	C15	Monolithic, 50V, .1 μ F	230-37
C5	Monolithic, 50V, .1 μ F	230-37	C16	Monolithic, 50V, .1 μ F	230-37
C6	Monolithic, 50V, .1 μ F	230-37	C17	Monolithic, 50V, .1 μ F	230-37
C7	Monolithic, 50V, .1 μ F	230-37	C18	Monolithic, 50V, .1 μ F	230-37
C8	Monolithic, 50V, .1 μ F	230-37	C19	Monolithic, 50V, .1 μ F	230-37
C9	Monolithic, 50V, .1 μ F	230-37	C20	Monolithic, 50V, .1 μ F	230-37
C10	Mica, 250V, 270 pF	223-270	C21	Monolithic, 50V, .1 μ F	230-37
C11	Monolithic, 50V, .01 μ F	250-77	C22	Monolithic, 50V, .1 μ F	230-37
			C23	Mylar, 250V, 1 μ F	210-36
			C24	Tantalum, 25V, 10 μ F	250-42
			C25	Tantalum, 25V, 10 μ F	250-42
			C26	Monolithic, 50V, .1 μ F	230-37
			C27	Mylar, 250V, .47 μ F	210-28

DIODES

REF. DES.	DESCRIPTION	WILTRON PART NO.
CR1	Silicon, 1N4446	10-1N4446
CR2	Reference, 1N823, 6.2V, 0.4W	10-1N823
CR3	Silicon, 1N4446	10-1N4446
CR4	Zener, 1N751A, 5.1V, 0.4W	10-1N751A
CR5	Silicon, 1N4446	10-1N4446
CR6	Silicon, 1N4446	10-1N4446
CR7	Silicon, 1N4446	10-1N4446
CR8	Silicon, 1N4446	10-1N4446
CR9	Zener, 1N751A, 5.1V, 0.4W	10-1N751A
CR10	Hot-carrier, MBD-501	10-4
CR11	Zener, 1N758A, 10V, 0.4W	10-1N758A
CR12	Silicon, 1N4446	10-1N4446
CR13	Zener, 1N751A, 5.1V, 0.4W	10-1N751A
CR14	Zener, 1N746A, 3.3V, 0.4W	10-1N746A
CR15	Zener, 1N751A, 5.1V, 0.4W	10-1N751A
CR16	Silicon, 1N4446	10-1N4446

TRANSISTORS

REF. DES.	DESCRIPTION	WILTRON PART NO.
Q1	2N3694, PNP, 0.2W	20-2N3694
Q2	2N4249, NPN, 0.4W	20-2N4249
Q3	2N3694, PNP, 0.2W	20-2N3694
Q4	2N3694, PNP, 0.2W	20-2N3694
Q5	2N3694, PNP, 0.2W	20-2N3694
Q6	2N4249, NPN, 0.4W	20-2N4249
Q7	2N3694, PNP, 0.2W	20-2N3694
Q8	J112, JFET	20-17
Q9	J112, JFET	20-17
Q10	2N3694, PNP, 0.2W	20-2N3694
Q11	2N4249, NPN, 0.4W	20-2N4249
Q12	2N3694, PNP, 0.2W	20-2N3694
Q13	2N4249, NPN, 0.4W	20-2N4249

RESISTORS

REF. DES.	DESCRIPTION	WILTRON PART NO.
R1	MF, 1/4W, 1%, 1.15 k Ω	110-1.15k-1
R2	MF, 1/4W, 1%, 17.4 k Ω	110-17.4k-1
R3	MF, 1/4W, 1%, 10 k Ω	110-10k-1
R4	MF, 1/4W, 1%, 9.76 k Ω	110-9.76k-1
R5	MF, 1/4W, 1%, 56.2 Ω	110-56.2-1
R6	Variable, 1/2W, 10%, 200 k Ω	156-200k
R7	MF, 1/4W, 1%, 1 M Ω	110-1M-1A
R8	MF, 1/4W, 1%, 4.99 k Ω	110-4.99k-1
R9	MF, 1/4W, 1%, 2.74 k Ω	110-2.74k-1
R10	Variable, 1/2W, 10%, 10 k Ω	156-10k
R11	MF, 1/4W, 1%, 10.2 k Ω	110-10.2k-1
R12	MF, 1/4W, 1%, 10 k Ω	110-10k-1
R13	MF, 1/4W, 1%, 1.07 k Ω	110-1.07k-1
R14	MF, 1/4W, 1%, 19.6 k Ω	110-19.6k-1
R15	MF, 1/4W, 1%, 10 k Ω	110-10k-1
R16	MF, 1/4W, 1%, 392 k Ω	110-392k-1
R17	Variable, 1/2W, 10%, 500 k Ω	156-500k
R18	MF, 1/4W, 1%, 3.48 k Ω	110-3.48k-1
R19	MF, 1/4W, 1%, 10 k Ω	110-10k-1
R20	MF, 1/4W, 1%, 100 Ω	110-100-1
R21	MF, 1/4W, 1%, 2.43 k Ω	110-2.43k-1
R22	MF, 1/4W, 1%, 10 k Ω	110-10k-1
R23	MF, 1/4W, 1%, 10 k Ω	110-10k-1
R24	MF, 1/4W, 1%, 10 k Ω	110-10k-1
R25	MF, 1/4W, 1%, 10 k Ω	110-10k-1

R26	MF, 1/4W, 1%, 20 k Ω	110-20k-1
R27	MF, 1/4W, 1%, 511 Ω	110-511-1
R28	MF, 1/4W, 1%, 10 k Ω	110-10k-1
R29	MF, 1/4W, 1%, 10 k Ω	110-10k-1
R30	MF, 1/4W, 1%, 1.1 k Ω	110-1.1k-1
R31	Variable, 1/2W, 10%, 2 k Ω	156-2k
R32	MF, 1/4W, 1%, 9.53 k Ω	110-9.53k-1
R33	MF, 1/4W, 1%, 20 k Ω	110-20k-1
R34	MF, 1/4W, 1%, 49.9 k Ω	110-49.9k-1
R35	MF, 1/4W, 1%, 100 Ω	110-100-1
R36	MF, 1/4W, 1%, 14.7 k Ω	110-14.7k-1
R37	MF, 1/4W, 1%, 10 k Ω	110-10k-1
R38	MF, 1/4W, 1%, 14.7 k Ω	110-14.7k-1
R39	Variable, 1/2W, 10%, 1 k Ω	156-1k
R40	MF, 1/4W, 1%, 14.7 k Ω	110-14.7k-1
R41	CC, 1/4W, 5%, 2.2 M Ω	101-2.2M-5
R42	MF, 1/4W, 1%, 49.9 k Ω	110-49.9k-1
R43	MF, 1/4W, 1%, 14.7 k Ω	110-14.7k-1
R44	MF, 1/4W, 1%, 20 k Ω	110-20k-1
R45	MF, 1/4W, 1%, 10 k Ω	110-10k-1
R46	MF, 1/4W, 1%, 10 k Ω	110-10k-1
R47	MF, 1/4W, 1%, 1.21 k Ω	110-1.21k-1
R48	MF, 1/4W, 1%, 20 k Ω	110-20k-1
R49	MF, 1/4W, 1%, 20 k Ω	110-20k-1
R50	MF, 1/4W, 1%, 140 k Ω	110-140k-1
R51	MF, 1/4W, 1%, 10 k Ω	110-10k-1
R52	MF, 1/4W, 1%, 511 Ω	110-511-1
R53	MF, 1/4W, 1%, 10 k Ω	110-10k-1
R54	MF, 1/4W, 1%, 10 k Ω	110-10k-1
R55	MF, 1/4W, 1%, 10 k Ω	110-10k-1
R56	MF, 1/4W, 1%, 10 k Ω	110-10k-1
R57	MF, 1/4W, 1%, 10 k Ω	110-10k-1
R58	MF, 1/4W, 1%, 10 k Ω	110-10k-1
R59	MF, 1/4W, 1%, 34 k Ω	110-34k-1
R60	MF, 1/4W, 1%, 10 k Ω	110-10k-1
R61	MF, 1/4W, 1%, 3.48 k Ω	110-3.48k-1
R62	MF, 1/4W, 1%, 10 k Ω	110-10k-1
R63	MF, 1/4W, 1%, 10 k Ω	110-10k-1
R64	MF, 1/4W, 1%, 20 k Ω	110-20k-1
R65	MF, 1/4W, 1%, 10 k Ω	110-10k-1
R66	MF, 1/4W, 1%, 140 k Ω	110-140k-1
R67	MF, 1/4W, 1%, 10 k Ω	110-10k-1
R68	MF, 1/4W, 1%, 10 k Ω	110-10k-1
R69	MF, 1/4W, 1%, 1 k Ω	110-1k-1
R70	MF, 1/4W, 1%, 10 k Ω	110-10k-1
R71	MF, 1/4W, 1%, 3.48 k Ω	110-3.48k-1
R72	MF, 1/4W, 1%, 10 k Ω	110-10k-1
R73	MF, 1/4W, 1%, 10 k Ω	110-10k-1
R74	MF, 1/4W, 1%, 10 k Ω	110-10k-1
R75	CC, 1/4W, 5%, 1.2 M Ω	101-1.2M-5
R76	Variable, 1/2W, 10%, 1 M Ω	156-1M
R77	MF, 1/4W, 1%, 1 M Ω	110-1M-1A
R78	MF, 1/4W, 1%, 10 k Ω	110-10k-1
R79	MF, 1/4W, 1%, 10 k Ω	110-10k-1

INTEGRATED CIRCUITS

REF. DES.	DESCRIPTION	WILTRON PART NO.
U1	Dual D Flip-Flop, 74LS74	54-44
U2	Quad AND, 74LS08	54-74LS08
U3	Timer, NE-555	54-555
U4	Counter, 74LS161	54-60
U5	Hex Inverter, 74LS04	54-74LS04
U6	Decoder, 74LS138	54-74LS138
U7	Octal Latch, 74LS374	54-41
U8	2-1 Multiplexer, 74LS157	54-59
U9	4-Bit Counter, 74LS191	54-120
U10	Quad Inverter, 74LS05	54-105

U11	Dual D Flip-Flop, 74LS74	54-44	U26	Quad NAND, 74LS01	54-74LS01
U12	2-1 Multiplexer, 74LS157	54-59	U27	Quad NOR, 74LS02	54-57
U13	4-Bit Counter, 74LS191	54-120	U28	Dual Switch, DG200	50-DG200BA
U14	Octal Latch, 74LS374	54-41			
U15	8-Bit Latch/DAC, AD7524	54-129			
U16	Dual D Flip-Flop, 74LS74	54-44			
U17	Quad NAND Gate, 74LS00	54-74LS00			
U18	Dual Op-Amp, TL072	54-53			
U19	Data Selector, 74LS151	54-119			
U20	Dual Op-Amp, TL072	54-53			
U21	Quad Switch, DG201	54-24			
U22	Dual D Flip-Flop, 74LS74	54-44			
U23	4-Input NAND, 74LS20	54-74LS20			
U24	Dual D Flip-Flop, 74LS74	54-44			
U25	QUAD Comparator, LM339	54-45			

MISCELLANEOUS

REF. DES.	DESCRIPTION	WILTRON PART NO.
K1	Relay	690-28
S1	Slide Switch	420-14
TP1		
thru		
TP7	Test Points	706-44
---	Ejector, P.C. Board	553-96

Table 6-3. A3 Marker Generator (660-D-8003)

<u>CAPACITORS</u>			<u>TRANSISTORS</u>		
REF. DES.	DESCRIPTION	WILTRON PART NO.	REF. DES.	DESCRIPTION	WILTRON PART NO.
C1	Tantalum, 68 μ F, 6V	250-58	CR3	Not Used	
C2	Monolithic, .1 μ F, 50V	230-37	CR4	Shottky, MBD-501	10-4
C3	Monolithic, .1 μ F, 50V	230-37	CR5	Not Used	
C4	Monolithic, .1 μ F, 50V	230-37	CR6	Shottky, MBD-501	10-4
C5	Not Used		CR7	Not Used	
C6	Not Used		CR8	Zener, 30V, 5%, 1W	10-1N4751A
C7	Tantalum, 10 μ F, 25V	250-42	CR9	Silicon, 1N4446	10-1N4446
C8	Tantalum, 10 μ F, 25V	250-42	CR10	Silicon, 1N4446	10-1N4446
C9	Monolithic, .1 μ F, 50V	230-37	CR11	Silicon, 1N4446	10-1N4446
C10	Monolithic, .1 μ F, 50V	230-37	CR12	Silicon, 1N4446	10-1N4446
C11	Tantalum, 10 μ F, 25V	250-42	CR13	Silicon, 1N4446	10-1N4446
C12	Monolithic, .1 μ F, 50V	230-37	CR14	Silicon, 1N4446	10-1N4446
C13	Monolithic, .1 μ F, 50V	230-37	CR15	Silicon, 1N4446	10-1N4446
C14	Mica, 20 pF	220-20	CR16	Silicon, 1N4446	10-1N4446
C15	Mica, 20 pF	220-20	CR17	Zener, 30V, 5%, 1W	10-1N4751A
C16	Mica, 20 pF	220-20	CR18	Silicon, 1N4446	10-1N4446
C17	Monolithic, .1 μ F, 50V	230-37	CR19	Silicon, 1N4446	10-1N4446
C18	Monolithic, .1 μ F, 50V	230-37	CR20	Silicon, 1N4446	10-1N4446
C19	Monolithic, .1 μ F, 50V	230-37	CR21	Silicon, 1N4446	10-1N4446
C20	Monolithic, .1 μ F, 50V	230-37	CR22	Silicon, 1N4446	10-1N4446
C21	Mica, 3 pF	223-3	CR23	Zener, 3.3V, 5%, .4W	10-1N746A
C22	Mica, 3 pF	223-3	CR24	Silicon, 1N4446	10-1N4446
C23	Monolithic, .1 μ F, 50V	230-37	CR25	Silicon, 1N4446	10-1N4446
C24	Monolithic, .1 μ F, 50V	230-37	CR26	Silicon, 1N4446	10-1N4446
C25	Monolithic, .1 μ F, 50V	230-37	CR27	Zener, 4.7V, 5%, .4W	10-11
C26	Monolithic, .1 μ F, 50V	230-37	CR28	Silicon, 1N4446	10-1N4446
C27	Monolithic, .01 μ F, 100V	250-77			
C28	Monolithic, .01 μ F, 100V	250-77			
C29	Mica, 150 pF	220-150			
C30	Tantalum, 10 μ F, 25V	250-42			
C31	Monolithic, .1 μ F, 50V	230-37			
C32	Tantalum, 10 μ F, 25V	250-42			
C33	Monolithic, .01 μ F, 100V	250-77			
C34	Monolithic, .1 μ F, 50V	230-37			
C35	Monolithic, .1 μ F, 50V	230-37			

DIODES

REF. DES.	DESCRIPTION	WILTRON PART NO.
CR1	Reference, 1N823, 6V, 0.4W	10-1N823
CR2	Shottky, MBD-501	10-4

RESISTORS

REF. DES.	DESCRIPTION	WILTRON PART NO.
R1	MF, 1/4W, 1%, 10 k Ω	110-10k-1
R2	MF, 1/4W, 1%, 10 k Ω	110-10k-1
R3	MF, 1/4W, 1%, 10 k Ω	110-10k-1

R4	MF, 1/4W, 1%, 10 kΩ	110-10k-1
R5	MF, 1/4W, 1%, 10 kΩ	110-10k-1
R6	MF, 1/4W, 1%, 10 kΩ	110-10k-1
R7	MF, 1/4W, 1%, 1 kΩ	110-1k-1
R8	MF, 1/4W, 1%, 10 kΩ	110-10k-1
R9	MF, 1/4W, 1%, 16.2 kΩ	110-16.2k-1
R10	MF, 1/4W, 1%, 10 kΩ	110-10k-1
R11	MF, 1/4W, 1%, 16.2 kΩ	110-16.2k-1
R12	MF, 1/4W, 1%, 10 kΩ	110-10k-1
R13	Variable, 1/2W, 10%, 2 kΩ	156-2k
R14	MF, 1/4W, 1%, 1 kΩ	110-1k-1
R15	MF, 1/4W, 1%, 1 kΩ	110-1k-1
R16	MF, 1/4W, 1%, 1 kΩ	110-1k-1
R17	MF, 1/4W, 1%, 1 MΩ	110-1M-1A
R18	MF, 1/4W, 1%, 1 MΩ	110-1M-1A
R19	MF, 1/4W, 1%, 10 kΩ	110-10k-1
R20	Variable, 1/2W, 10%, 2 kΩ	156-2k
R21	MF, 1/4W, 1%, 1 kΩ	110-1k-1
R22	MF, 1/4W, 1%, 1 kΩ	110-1k-1
R23	MF, 1/4W, 1%, 1 kΩ	110-1k-1
R24	MF, 1/4W, 1%, 1 MΩ	110-1M-1A
R25	MF, 1/4W, 1%, 1 MΩ	110-1M-1A
R26	MF, 1/4W, 1%, 10 kΩ	110-10k-1
R27	Variable, 1/2W, 10%, 2 kΩ	156-2k
R28	MF, 1/4W, 1%, 1 kΩ	110-1k-1
R29	MF, 1/4W, 1%, 1 kΩ	110-1k-1
R30	MF, 1/4W, 1%, 1 kΩ	110-1k-1
R31	MF, 1/4W, 1%, 1 MΩ	110-1M-1A
R32	MF, 1/4W, 1%, 1 MΩ	110-1M-1A
R33	MF, 1/4W, 1%, 17.8 kΩ	110-17.8k-1
R34	MF, 1/4W, 1%, 10 kΩ	110-10k-1
R35	MF, 1/4W, 1%, 10 kΩ	110-10k-1
R36	MF, 1/4W, 1%, 10 kΩ	110-10k-1
R37	MF, 1/4W, 1%, 24.9 kΩ	110-24.9k-1
R38	MF, 1/4W, 1%, 100 kΩ	110-100k-1
R39	MF, 1/4W, 1%, 100 kΩ	110-100k-1
R40	MF, 1/4W, 1%, 133 kΩ	110-133k-1
R41	MF, 1/4W, 1%, 100 kΩ	110-100k-1
R42	MF, 1/4W, 1%, 17.8 kΩ	110-17.8k-1
R43	MF, 1/4W, 1%, 10 kΩ	110-10k-1
R44	MF, 1/4W, 1%, 10 kΩ	110-10k-1
R45	MF, 1/4W, 1%, 10 kΩ	110-10k-1
R46	MF, 1/4W, 1%, 24.9 kΩ	110-24.9k-1
R47	MF, 1/4W, 1%, 100 kΩ	110-100k-1
R48	MF, 1/4W, 1%, 100 kΩ	110-100k-1
R49	MF, 1/4W, 1%, 133 kΩ	110-133k-1
R50	MF, 1/4W, 1%, 100 kΩ	110-100k-1
R51	MF, 1/4W, 1%, 1 kΩ	110-1k-1
R52	MF, 1/4W, 1%, 17.8 kΩ	110-17.8k-1
R53	MF, 1/4W, 1%, 10 kΩ	110-10k-1
R54	MF, 1/4W, 1%, 10 kΩ	110-10k-1
R55	MF, 1/4W, 1%, 10 kΩ	110-10k-1
R56	MF, 1/4W, 1%, 24.9 kΩ	110-24.9k-1
R57	MF, 1/4W, 1%, 4.99 kΩ	110-4.99k-1
R58	MF, 1/4W, 1%, 200 kΩ	110-200k-1
R59	MF, 1/4W, 1%, 12.4 kΩ	110-12.4k-1
R60	MF, 1/4W, 1%, 887Ω	110-887-1
R61	MF, 1/4W, 1%, 20 kΩ	110-20k-1
R62	Variable, 1/2W, 10%, 200 kΩ	156-200k
R63	MF, 1/4W, 1%, 19.6 kΩ	110-19.6k-1
R64	MF, 1/4W, 1%, 49.9 kΩ	110-49.9k-1
R65	MF, 1/4W, 1%, 10 kΩ	110-10k-1
R66	MF, 1/4W, 1%, 1.47 kΩ	110-1.47k-1
R67	MF, 1/4W, 1%, 10 kΩ	110-10k-1

R68	MF, 1/4W, 1%, 1 kΩ	110-1k-1
R69	MF, 1/4W, 1%, 20 kΩ	110-20k-1
R70	MF, 1/4W, 1%, 301 kΩ	110-301k
R71	MF, 1/4W, 1%, 10 kΩ	110-10k-1
R72	MF, 1/4W, 1%, 100 kΩ	110-100k-1
R73	MF, 1/4W, 1%, 10 kΩ	110-10k-1
R74	MF, 1/4W, 1%, 100 kΩ	110-100k-1
R75	MF, 1/4W, 1%, 1 MΩ	110-1M-1A
R76	MF, 1/4W, 1%, 10 kΩ	110-10k-1
R77	MF, 1/4W, 1%, 20 kΩ	110-20k-1
R78	MF, 1/4W, 1%, 100 kΩ	110-100k-1
R79	MF, 1/4W, 1%, 30.1 kΩ	110-30.1k-1
R80	MF, 1/4W, 1%, 10 kΩ	110-10k-1
R81	MF, 1/4W, 1%, 100 kΩ	110-100k-1
R82	MF, 1/4W, 1%, 100 kΩ	110-100k-1
R83	MF, 1/4W, 1%, 100 kΩ	110-100k-1
R84	MF, 1/4W, 1%, 178 kΩ	110-178k-1
R85	MF, 1/4W, 1%, 27.4 kΩ	110-27.4k-1
R86	MF, 1/4W, 1%, 5.11Ω	110-5.11-1
R87	MF, 1/4W, 1%, 10 kΩ	110-10k-1
R88	MF, 1/4W, 1%, 20 kΩ	110-20k-1
R89	MF, 1/4W, 1%, 10 kΩ	110-10k-1
R90	Variable, 1/2W, 10%, 200 kΩ	156-200k
R91	MF, 1/4W, 1%, 10 kΩ	110-10k-1
R92	MF, 1/4W, 1%, 20 kΩ	110-20k-1
R93	MF, 1/4W, 1%, 1 kΩ	110-1k-1
R94	MF, 1/4W, 1%, 1 kΩ	110-1k-1
R95	MF, 1/4W, 1%, 1 kΩ	110-1k-1

INTEGRATED CIRCUITS

REF. DES.	DESCRIPTION	WILTRON PART NO.
U1	Octal Latch, 74LS374	54-41
U2	Quad NAND Gate, 74LS01	54-74LS01
U3	Op Amp, TL072CP	54-53
U4	Not Used	
U5	8 Bit DAC, AD7524	54-129
U6	8 Bit DAC, AD7524	54-129
U7	8 Bit DAC, AD7524	54-129
U8	Quad Op Amp, RC4136	54-RC4136
U9	Quad Op Amp, RC4136	54-RC4136
U10	Quad Op Amp, RC4136	54-RC4136
U11	Quad AND Gate, 74LS09	54-96
U12	Voltage Comparator, LM311	54-30
U13	Op Amp, TL072CP	54-53
U14	Op Amp, LM339	54-45
U15	Dual Flip-Flop, 74LS74	54-44
U16	Dual One-Shot, 96L02	54-96L02
U17	2-input NAND, 74LS10	54-42
U18	8 Bit ADC, ADC0804LCN	54-161
U19	Octal Latch, 74LS374	54-41

MISCELLANEOUS

REF. DES.	DESCRIPTION	WILTRON PART NO.
TP1 thru TP19	Test Points	706-44
---	Ejector, PCB	553-96

Table 6-4. A4 ALC (660-D-8004)

CAPACITORS			RESISTORS		
REF. DES.	DESCRIPTION	WILTRON PART NO.	REF. DES.	DESCRIPTION	WILTRON PART NO.
C1	Ceramic Disc, .1 μ F	230-37	R1	MF, 1/4W, 1%, 10 k Ω	110-10k-1
C2	Ceramic Disc, .1 μ F	230-37	R2	MF, 1/4W, 1%, 8.25 k Ω	110-8.25k-1
C3	Tantalum, 25V, 10 μ F	250-42	R3	Variable, Single-Turn, 10 k Ω	156-10k
C4	Tantalum, 25V, 10 μ F	250-42	R4	MF, 1/4W, 1%, 3.01 k Ω	110-3.01k-1
C5	Tantalum, 6V, 68 μ F	250-58	R5	Variable, Multi-turn, 20 k Ω	157-20k
C6	Ceramic Disc, .1 μ F	230-37	R6	MF, 1/4W, 1%, 3.01 k Ω	110-3.01k-1
C7	Ceramic Disc, .1 μ F	230-37	R7	MF, 1/4W, 1%, 13.3 k Ω	110-13.3k-1
C8	Ceramic Disc, .1 μ F	230-37	R8	MF, 1/4W, 1%, 54.9 k Ω	110-54.9k-1
C9	Ceramic Disc, .1 μ F	230-37	R9	Variable, Single-Turn, 20 k Ω	156-20k
C10	Mica, 27 pF	220-27	R10	MF, 1/4W, 1%, 5.49 k Ω	110-5.49k-1
C11	Ceramic Disc, .1 μ F	230-37	R11	Variable, Multi-turn, 20 k Ω	157-20k
C12	Ceramic Disc, .1 μ F	230-37	R12	MF, 1/4W, 1%, 8.25 k Ω	110-8.25k-1
C13	Ceramic Disc, .1 μ F	230-37	R13	MF, 1/4W, 1%, 64.9 k Ω	110-64.9k-1
C14	Ceramic Disc, .1 μ F	230-37	R14	MF, 1/4W, 1%, 316 k Ω	110-316k-1
C15	Polycarbonate, .0047 μ F	210-50	R15	MF, 1/4W, 1%, 20 k Ω	110-20k-1
C16	Polycarbonate, .0047 μ F	210-50	R16	MF, 1/4W, 1%, 64.9 k Ω	110-64.9k-1
C17	Ceramic Disc, .1 μ F	230-37	R17	MF, 1/4W, 1%, 5.49 k Ω	110-5.49k-1
C18	Ceramic Disc, .01 μ F	230-11	R18	MF, 1/4W, 1%, 5.49 k Ω	110-5.49k-1
C19	Ceramic Disc, .0047 μ F	230-36	R19	Variable, Multi-turn, 20 k Ω	157-20k
C20	Ceramic Disc, .02 μ F	230-27	R20	MF, 1/4W, 1%, 64.9 k Ω	110-64.9k-1
C21	Ceramic Disc, .1 μ F	230-37	R21	MF, 1/4W, 1%, 10 k Ω	110-10k-1
C22	Ceramic Disc, .1 μ F	230-37	R22	MF, 1/4W, 1%, 20 k Ω	110-20k-1
C23	Aluminum, 63V, 47 μ F	250-51	R23	MF, 1/4W, 1%, 10 k Ω	110-10k-1
C24	Not Used		R24	MF, 1/4W, 1%, 10 k Ω	110-10k-1
C25	Ceramic Disc, .01 μ F	230-11	R25	MF, 1/4W, 1%, 1.07 k Ω	110-1.07k-1
			R26	MF, 1/4W, 1%, 19.6 k Ω	110-19.6k-1
			R27	MF, 1/4W, 1%, 12.1 k Ω	110-12.1k-1
			R28	MF, 1/4W, 1%, 10.2 k Ω	110-10.2k-1
			R29	MF, 1/4W, 1%, 16.5 k Ω	110-16.5k-1
			R31	MF, 1/4W, 1%, 51.1 Ω	110-51.1-1
			R32	MF, 1/4W, 1%, 51.1 Ω	110-51.1-1
			R34	MF, 1/4W, 1%, 511 Ω	110-511-1
			R35	MF, 1/4W, 1%, 100 k Ω	110-100k-1
			R36	MF, 1/4W, 1%, 10 k Ω	110-10k-1
			R37	MF, 1/4W, 1%, 511 Ω	110-511-1
			R38	MF, 1/4W, 1%, 100 k Ω	110-100k-1
			R39	MF, 1/4W, 1%, 10 k Ω	110-10k-1
			R40	MF, 1/4W, 0.1%, 900 Ω	113-900-0.1
			R41	MF, 1/4W, 0.1%, 900 Ω	113-900-0.1
			R42	MF, 1/4W, 1%, 12.4 k Ω	110-12.4k-1
			R43	MF, 1/4W, 1%, 261 Ω	110-261-1
			R44	MF, 1/4W, 1%, 261 Ω	110-261-1
			R45	MF, 1/4W, 1%, 12.4 k Ω	110-12.4k-1
			R46	MF, 1/4W, 1%, 604 Ω	110-604-1
			R47	MF, 1/4W, 1%, 576 Ω	110-576-1
			R48	MF, 1/4W, 1%, 12.4 k Ω	110-12.4k-1
			R49	MF, 1/4W, 1%, 1.82 k Ω	110-1.82k-1
			R50	MF, 1/4W, 1%, 953 Ω	110-953-1
			R51	MF, 1/4W, 1%, 4.99 k Ω	110-4.99k-1
			R52	MF, 1/4W, 1%, 54.9 k Ω	110-54.9k-1
			R53	MF, 1/4W, 1%, 15 k Ω	110-15k-1
			R54	MF, 1/4W, 1%, 12.4 k Ω	110-12.4k-1
			R55	MF, 1/4W, 1%, 487 Ω	110-487-1
			R56	MF, 1/4W, 1%, 464 Ω	110-464-1
			R57	MF, 1/4W, 1%, 12.4 k Ω	110-12.4k-1
			R58	MF, 1/4W, 1%, 2.43 k Ω	110-2.43k-1
			R59	MF, 1/4W, 1%, 2.05 k Ω	110-2.05k-1
			R60	MF, 1/4W, 1%, 12.4 k Ω	110-12.4k-1
			R61	MF, 1/4W, 1%, 12.4 k Ω	110-12.4k-1
			R62	MF, 1/4W, 0.1%, 20 k Ω	113-20k-0.1
			R63	MF, 1/4W, 0.1%, 20 k Ω	113-20k-0.1
			R64	MF, 1/4W, 0.1%, 20 k Ω	113-20k-0.1
			R65	MF, 1/4W, 0.1%, 20 k Ω	113-20k-0.1

DIODES		
REF. DES.	DESCRIPTION	WILTRON PART NO.
CR1	Silicon, 1N4446	10-1N4446
CR2	Silicon, 1N4446	10-1N4446
CR3	Silicon, 1N4446	10-1N4446
CR4	Silicon, 1N4446	10-1N4446
CR5	Silicon, 1N4446	10-1N4446
CR6	Silicon, 1N4446	10-1N4446
CR7	Reference, 6.2V, 1N823	10-1N823
CR8	Zener, 5.1V, 0.4W, 1N751A	10-1N751A
CR9	Silicon, 1N4446	10-1N4446
CR10	Silicon, 1N4446	10-1N4446
CR11	Silicon, 1N4446	10-1N4446
CR12	Silicon, 1N4446	10-1N4446
CR13	Silicon, 1N4446	10-1N4446
CR14	Silicon, 1N4446	10-1N4446
CR15	MBD-501	10-4
CR16	Silicon, 1N4446	10-1N4446
CR17	Silicon, 1N4446	10-1N4446
CR18	MBD-501	10-4
CR19	Silicon, 1N4446	10-1N4446
CR20	Silicon, 1N4446	10-1N4446

TRANSISTORS		
REF. DES.	DESCRIPTION	WILTRON PART NO.
Q1	NPN, .5W, 2N2222A	20-2N2222A
Q2	PNP, .4W, 2N4249	20-2N4249
Q3	PNP, .4W, 2N4249	20-2N4249
Q4	NPN, .4W, 2N3694	20-2N3694
Q5	NPN, .4W, 2N3694	20-2N3694

R66	Variable, Multi-turn, 2 k Ω	157-2k
R67	MF, 1/4W, 1%, 2.37 k Ω	110-2.37k-1
R68	Variable, Multi-turn, 2 k Ω	157-2k
R69	MF, 1/4W, 1%, 1.47 k Ω	110-1.47k-1
R70	Variable, Multi-turn, 2 k Ω	157-2k
R71	MF, 1/4W, 1%, 6.19 k Ω	110-6.19k-1
R72	Variable, Multi-turn, 2 k Ω	157-2k
R73	MF, 1/4W, 1%, 7.87 k Ω	110-7.87k-1
R74	MF, 1/4W, 1%, 10 k Ω	110-10k-1
R75	MF, 1/4W, 1%, 10 k Ω	110-10k-1
R76	CC, 1/4W, 5%, 10 M Ω	101-10M-5
R77	MF, 1/4W, 1%, 133 k Ω	110-133k-1
R78	MF, 1/4W, 1%, 2.49 k Ω	110-2.49k-1
R79	MF, 1/4W, 1%, 8.66 k Ω	110-8.66k-1
R80	Variable, Single-Turn, 2 k Ω	156-2k
R81	MF, 1/4W, 1%, 6.49 k Ω	110-6.49k-1
R82	Variable, Single-Turn, 2 k Ω	156-2k
R83	MF, 1/4W, 1%, 11.3 k Ω	110-11.3k-1
R84	Variable, Single-Turn, 2 k Ω	156-2k
R85	MF, 1/4W, 1%, 8.25 k Ω	110-8.25k-1
R86	Variable, Single-Turn, 2 k Ω	156-2k
R87	MF, 1/4W, 1%, 8.66 k Ω	110-8.66k-1
R88	Variable, Single-Turn, 2 k Ω	156-2k
R89	MF, 1/4W, 1%, 11 k Ω	110-11k-1
R90	Variable, Single-Turn, 5 k Ω	156-5k
R91	MF, 1/4W, 1%, 1 M Ω	110-1M-1A
R92	MF, 1/4W, 1%, 1 M Ω	110-1M-1A
R93	MF, 1/4W, 1%, 10 k Ω	110-10k-1
R94	MF, 1/4W, 1%, 1 M Ω	110-1M-1A
R95	MF, 1/4W, 1%, 1 M Ω	110-1M-1A
R96	MF, 1/4W, 1%, 1 M Ω	110-1M-1A
R97	MF, 1/4W, 1%, 10 k Ω	110-10k-1
R98	MF, 1/4W, 1%, 1 M Ω	110-1M-1A
R99	MF, 1/4W, 1%, 26.7 k Ω	110-26.7k-1
R100	MF, 1/4W, 1%, 42.2 k Ω	110-42.2k-1
R101	MF, 1/4W, 1%, 30.1 k Ω	110-30.1k-1
R102	MF, 1/4W, 1%, 30.1 k Ω	110-30.1k-1
R103	Variable, Multi-turn, 5 k Ω	157-5k
R104	MF, 1/4W, 1%, 301 k Ω	110-301k-1
R105	MF, 1/4W, 1%, 10 k Ω	110-10k-1
R106	MF, 1/4W, 1%, 9.76 k Ω	110-9.76k-1
R107	MF, 1/4W, 1%, 10 k Ω	110-10k-1
R108	MF, 1/4W, 1%, 511 k Ω	110-511k-1
R109	MF, 1/4W, 1%, 10 k Ω	110-10k-1
R110	MF, 1/4W, 1%, 10 k Ω	110-10k-1
R111	MF, 1/4W, 1%, 10 k Ω	110-10k-1
R112	MF, 1/4W, 1%, 10 k Ω	110-10k-1
R113	MF, 1/4W, 1%, 20 k Ω	110-20k-1
R114	MF, 1/4W, 1%, 20 k Ω	110-20k-1
R115	Variable, Single-Turn, 20 k Ω	156-20k
R116	MF, 1/4W, 1%, 16.5 k Ω	110-16.5k-1
R117	MF, 1/4W, 1%, 7.5 k Ω	110-7.5k-1
R118	MF, 1/4W, 1%, 5.11 k Ω	110-5.11k-1
R119	MF, 1/4W, 1%, 2 k Ω	110-2k-1
R120	MF, 1/4W, 1%, 15 k Ω	110-15k-1
R121	MF, 1/4W, 1%, 2 k Ω	110-2k-1
R122	MF, 1/4W, 1%, 511 Ω	110-511-1
R123	Variable, Single-Turn, 2 k Ω	156-2k
R124	Variable, Single-Turn, 2 k Ω	156-2k
R125	MF, 1/4W, 1%, 1 k Ω	110-1k-1
R126	MF, 1/4W, 1%, 1 k Ω	110-1k-1
R127	MF, 1/4W, 1%, 100 k Ω	110-100k-1
R128	MF, 1/4W, 1%, 10 k Ω	110-10k-1

R129	MF, 1/4W, 1%, 10 k Ω	110-10k-1
R130	MF, 1/4W, 1%, 4.02 k Ω	110-4.02k-1
R131	MF, 1/4W, 1%, 1 k Ω	110-1k-1
R132	MF, 1/4W, 1%, 4.02 k Ω	110-4.02k-1
R133	MF, 1/4W, 1%, 4.02 k Ω	110-4.02k-1
R134	MF, 1/4W, 1%, 20 k Ω	110-20k-1
R135	MF, 1/4W, 1%, 4.02 k Ω	110-4.02k-1
R136	MF, 1/4W, 1%, 1 k Ω	110-1k-1
R137	MF, 1/4W, 1%, 1 k Ω	110-1k-1
R138	MF, 1/4W, 1%, 4.99 k Ω	110-4.99k-1
R139	MF, 1/4W, 1%, 649 Ω	110-649-1
R140	MF, 1/4W, 1%, 4.99 k Ω	110-4.99k-1
R141	MF, 1/4W, 1%, 887 Ω	110-887-1
R142	Variable, Single-Turn, 20 k Ω	156-20k
R143	MF, 1/4W, 1%, 4.99 k Ω	110-4.99k-1
R144	MF, 1/4W, 1%, 15 k Ω	110-15k-1
R145	MF, 1/4W, 1%, 1 k Ω	110-1k-1
R146	MF, 1/4W, 1%, 10 k Ω	110-10k-1
R147	MF, 1/4W, 1%, 3.01 k Ω	110-3.01k-1
R148	MF, 1/4W, 1%, 10 k Ω	110-10k-1
RP1	Package, 1 k Ω	123-1

INTEGRATED CIRCUITS

REF. DES.	DESCRIPTION	WILTRON PART NO.
U1	Quad NAND, 74LS00	54-74LS00
U2	Hex Inverter, 74LS04	54-74LS04
U3	Triple NAND, 74LS10	54-42
U4	Op Amp, LF356N	50-9
U5	Switch, DG201	54-24
U6	Op Amp, LF356N	50-9
U7	Op Amp, LF356N	50-9
U8	Op Amp, TL072	54-53
U9	Op Amp, TL072	54-53
U10	Op Amp, TL072	54-53
U11	Quad Comparator, MC3302P	54-MC3302P
U12	Transistor Array, CA3054	54-6
U13	Transistor Array, CA3054	54-6
U14	Op Amp, LF356N	50-9
U15	Transistor Array, CA3054	54-6
U16	Op Amp, TL072	54-53
U17	Switch, DG201	54-24
U18	Op Amp, TL074	54-132
U19	Op Amp, TL074	54-132
U20	Switch, DG201	54-24
U21	Op Amp, LF356N	50-9
U22	8 Bit DAC, AD 7524	54-129
U23	Quad Schmitt NAND, 74LS132	54-74LS132
U24	Octal Latch, 74LS374	54-41
U25	Quad Transparent Latch, 74LS75	54-74LS75

MISCELLANEOUS

REF. DES.	DESCRIPTION	WILTRON PART NO.
TP1 thru TP7	Pin, Test Point	706-44
---	Ejector, PC Board	553-96

Table 6-5. A5 Frequency Instruction (660-D-8005)

<u>CAPACITORS</u>					
REF DES.	DESCRIPTION	WILTRON PART NO.			
C1	Mica, 100 pF	220-100			
C2	Mica, 100 pF	220-100			
C3	Disc Ceramic, 0.001 μF	230-30			
C4	Monolithic, 0.1 μF	230-37			
C5	Tantalum, 4.7 μF, 35V	250-39			
C6	Monolithic, 0.1 μF	230-37			
C7	Tantalum, 4.7 μF, 35V	250-39			
C8	Monolithic, 0.1 μF	230-37			
C9	Monolithic, 0.1 μF	230-37			
C10	Monolithic, 0.1 μF	230-37			
C11	Monolithic, 0.1 μF	230-37			
C12	Tantalum, 4.7 μF, 35V	250-39			
C13	Tantalum, 4.7 μF, 35V	250-39			
C14	Monolithic, 0.1 μF	230-37			
C15	Monolithic, 0.1 μF	230-37			
C16	Tantalum, 4.7 μF, 35V	250-39			
C17	Tantalum, 4.7 μF, 35V	250-39			
C18	Monolithic, 0.1 μF	230-37			
C19	Monolithic, 0.1 μF	230-37			
C20	Tantalum, 4.7 μF, 35V	250-39			
C21	Tantalum, 4.7 μF, 35V	250-39			
C22	Monolithic, 0.1 μF	230-37			
C23	Monolithic, 0.1 μF	230-37			
C24	Monolithic, 0.1 μF	230-37			
C25	Disc Ceramic, 0.001 μF	230-30			
C26	Mica, 100 pF	220-100			
C27	Disc Ceramic, 0.001 μF	230-30			
<u>DIODES</u>					
REF DES.	DESCRIPTION	WILTRON PART NO.			
CR1	Schottky, MBD-501	10-4			
CR2	Schottky, MBD-501	10-4			
CR3	Silicon, 1N4446	10-1N4446			
CR4	Silicon, 1N4446	10-1N4446			
CR5	Zener, 12V, 0.4W, 1N759A	10-1N759A			
CR6	Reference, 6.2V, 1N823	10-1N823			
CR7	Silicon, 1N4446	10-1N4446			
CR8	Silicon, 1N4446	10-1N4446			
CR9	Zener, 11V, 1N962B	10-1N962B			
CR10	Zener, 11V, 1N962B	10-1N962B			
<u>TRANSISTORS</u>					
REF DES.	DESCRIPTION	WILTRON PART NO.			
Q1	PNP, 2N6041	20-2N6041			
Q2	PNP, 2N2907A	20-2N2907A			
Q3	NPN, 2N2222A	20-2N2222A			
<u>RESISTORS</u>					
REF. DES.	DESCRIPTION	WILTRON PART NO.			
A1	Resistor Pack				
	a. 6609A	660-A-8145-1			
	b. 6617A	660-A-8145-2			
	c. 6621A	SPCL-A-11552			
			d. 6621A-40		SPCL-A-13074
			e. 6629A		SPCL-A-11587
			f. 6629A-40		SPCL-A-13081
			g. 6637A		660-A-8145-3
			h. 6637A-40		660-A-8145-3
			i. 6638A		660-A-8145-4
			j. 6642A		SPCL-A-11623
			k. 6647A		660-A-8145-3
			l. 6648A		660-A-8145-4
			m. 6653A		660-A-8145-5
			n. 6659A		660-A-8145-5
			A2	Resistor Pack	
			a. 6609A		660-A-12632-1
			b. 6617A		660-A-12732-2
			c. 6621A		SPCL-B-13091-5
			d. 6621A-40		SPCL-B-13091-5
			e. 6629A		SPCL-B-13091-9
			f. 6629A-40		SPCL-B-13091-9
			g. 6637A		660-A-12632-3
			h. 6637A-40		660-A-12632-3
			i. 6638A		660-A-12632-5
			j. 6642A		SPCL-B-13091-13
			k. 6647A		660-A-12632-4
			l. 6648A		660-A-12632-6
			m. 6653A		660-A-12632-9
			n. 6659A		660-A-12632-10
			RP1	Resistor Pack, 10 kΩ	123-6
			R1	MF, 1/4W, 1%, 10 kΩ	110-10k-1
			R2	MF, 1/4W, 1%, 2.37 kΩ	110-2.37k-1
			R3	MF, 1/4W, 1%, 2.37 kΩ	110-2.37k-1
			R4	MF, 1/4W, 1%, 3.92 kΩ	110-3.92k-1
			R5	MF, 1/4W, 1%, 392Ω	110-392-1
			R6	Part of A2	
			R7	Part of A2	
			R8	Variable, Multi-turn, 50 kΩ	157-50k
			R9	MF, 1/4W, 1%, 348 kΩ	110-348k-1
			R10	Variable, Multi-turn, 20 kΩ	157-20k
			R11	MF, 1/4W, 0.1%, 30 kΩ	113-30k-0.1
			R12	MF, 1/4W, 1%, 511Ω	110-511-1
			R13	Variable, Single-Turn, 500Ω	156-500
			R14	MF, 1/4W, 1%, 10 kΩ	110-10k-1
			R15	MF, 1/4W, 0.1%, 30 kΩ	113-30k-0.1
			R16	MF, 1/4W, 1%, 10 kΩ	110-10k-1
			R17	MF, 1/4W, 1%, 10 kΩ	110-10k-1
			R18	Part of A2	
			R19	Part of A2	
			R20	Part of A2	
			R21	Part of A2	
			R22	Part of A2	
			R23	MF, 1/4W, 0.1%, 30 kΩ	113-30k-0.1
			R24	MF, 1/4W, 1%, 511Ω	110-511-1
			R25	MF, 1/4W, 1%, 1 kΩ	110-1k-1
			R26	MF, 1/4W, 0.1%, 10 kΩ	113-10k-0.1
			R27	MF, 1/4W, 0.1%, 10 kΩ	113-10k-0.1
			R28	MF, 1/4W, 0.1%, 10 kΩ	113-10k-0.1
			R29	Variable, Multi-turn, 500Ω	157-500
			R30	MF, 1/4W, 0.1%, 30 kΩ	113-30k-0.1
			R31	MF, 1/4W, 0.1%, 10 kΩ	113-10k-0.1
			R32	MF, 1/4W, 0.1%, 10 kΩ	113-10k-0.1
			R33	MF, 1/4W, 0.1%, 10 kΩ	113-10k-0.1
			R34	MF, 1/4W, 0.1%, 10 kΩ	113-10k-0.1
			R35	MF, 1/4W, 1%, 27.4 kΩ	110-27.4k-1
			R36	MF, 1/4W, 0.1%, 10 kΩ	113-10k-0.1
			R37	Part of A2	
			R38	Part of A2	
			R39	MF, 1/4W, 1%, 511Ω	110-511-1
			R40	Variable, Multi-turn, 20k	157-20k
			R41	MF, 1/4W, 0.1%, 10 kΩ	113-10k-0.1

R42	MF, 1/4W, 1%, 10 kΩ	110-10k-1
R43	MF, 1/4W, 0.1%, 10 kΩ	113-10k-0.1
R44	MF, 1/4W, 0.1%, 10 kΩ	113-10k-0.1
R45	MF, 1/4W, 0.1%, 10 kΩ	113-10k-0.1
R46	Variable, Multi-turn, 20k	157-20k
R47	MF, 1/4W, 1%, 10Ω	110-10-1
R48	MF, 1/4W, 1%, 1 kΩ	110-1k-1
R49	Variable, Single-Turn, 1 kΩ	157-1k
R50	MF, 1/4W, 1%, 6.49 kΩ	110-6.49k-1
R51	MF, 1/4W, 1%, 4.32 kΩ	110-4.32k-1
R52	MF, 1/4W, 1%, 422Ω	110-422-1
R53	MF, 1/4W, 1%, 10 kΩ	110-10k-1
R54	MF, 1/4W, 1%, 1 kΩ	110-1k-1
R55	Variable, Single-Turn, 1 kΩ	157-1k
R56	MF, 1/4W, 1%, 3.83 kΩ	110-3.83k-1
R57	MF, 1/4W, 1%, 1.87 kΩ	110-1.87k-1
R58	MF, 1/4W, 1%, 10Ω	110-10-1
R59	MF, 1/4W, 0.1%, 10 kΩ	113-10k-0.1
R60	MF, 1/4W, 1%, 3.92 kΩ	110-3.92k-1
R61	MF, 1/4W, 1%, 10 kΩ	110-10k-1
R62	Variable, Single-Turn, 5k	156-5k
R63	MF, 1/4W, 1%, 10 kΩ	110-10k-1
R64	MF, 1/4W, 1%, 10 kΩ	110-10k-1
R65	MF, 1/4W, 1%, 10 kΩ	110-10k-1
R66	MF, 1/4W, 1%, 10 kΩ	110-10k-1
R67	MF, 1/4W, 1%, 100 kΩ	110-100k-1
R68	Variable, Multi-turn, 2 kΩ	157-2k
R69	Variable, Multi-turn, 2 kΩ	157-2k
R70	MF, 1/4W, 1%, 49.9 kΩ	110-49.9k-1
R71	Part of A2	
R72	Part of A2	
R73	Part of A2	
R74	MF, 1/4W, 1%, 49.9 kΩ	110-49.9k-1
R75	Variable, Single-Turn, 5 kΩ	156-5k
R76	MF, 1/4W, 1%, 3.16 kΩ	110-3.16k-1
R77	Variable, Single-Turn, 5 kΩ	156-5k
R78	MF, 1/4W, 1%, 2.49 kΩ	110-2.49k-1
R79	Variable, Single-Turn, 5 kΩ	156-5k
R80	MF, 1/4W, 1%, 6.81 kΩ	110-6.81k-1
R81	Variable, Single-Turn, 5 kΩ	156-5k
R82	MF, 1/4W, 1%, 3.01 kΩ	110-3.01k-1
R83	MF, 1/4W, 1%, 10 kΩ	110-10k-1
R84	MF, 1/4W, 1%, 10 kΩ	110-10k-1
R85	Part of A2	
R86	Part of A2	
R87	MF, 1/4W, 1%, 49.9 kΩ	110-49.9k-1
R88	MF, 1/4W, 1%, 10 kΩ	110-10k-1
R89	MF, 1/4W, 1%, 10 kΩ	110-10k-1

INTEGRATED CIRCUITS

REF. DES.	DESCRIPTION	WILTRON PART NO.
U1	Hex Inverter, 74LS00	54-74LS00

U2	8 Bit Multiplying DAC, MC1408L8	54-148
U3	Op Amp, 356	50-9
U4	8 Bit Multiplying DAC, MC1408L8	54-148
U5	Octal Latch, 74LS374	54-41
U6	Op Amp, OP05	50-87
U7	16 Bit DAC	54-150
U8	Octal Latch, 74LS374	54-41
U9	Octal Latch, 74LS374	54-41
U10	Dual FET-Input Op Amp, TL072	54-53
U11	Dual Analog Switch, DG200BA	50-DG200BA
U12	Op Amp, 301A	50-8
U13	Op Amp, 356	50-9
U14	Op Amp, 356	50-9
U15	Octal Latch, 74LS374	54-41
U16	Octal Latch, 74LS374	54-41
U17	Octal Latch, 74LS374	54-41
U18	Octal Latch, 74LS374	54-41
U19	12 Bit Multiplying DAC	54-149
U20	Op Amp, 356	50-9
U21	Dual FET-Input Op Amp, TL072	54-53
U22	Quad Analog Switch, LF13201N	54-20
U23	Op Amp, 356	50-9
U24	12 Bit Multiplying DAC	54-149
U25	Op Amp, 356	50-9
U26	Op Amp, OP05	50-87
U27	Dual FET-Input Op Amp, TL072	54-53
U28	Quad Analog Switch, LF13201N	54-20
U29	Triple NAND, 74LS10	54-42
U30	Op AMP, 356	50-9
U31	Quad D Flip-Flop, 74LS175	54-74LS175
U32	Octal Latch, 74LS374	54-41
U33	Quad Analog-Switch, LF13201N	54-20
U34	Quad Analog-Switch, LF13201N	54-20
U35	Dual FET-Input Op Amp, TL074	54-132

MISCELLANEOUS

REF. DES.	DESCRIPTION	WILTRON PART NO.
P2	Connector, 3-Pin	551-238
S1	Switch, DPDT	420-14
TP1 thru TP10	Pin, Test Point	706-44
----	Socket, I.C., 14-Pin	553-63
----	Socket, I.C. 24-Pin	553-67
----	Ejector, P.C. Board	553-96

Table 6-6. A6 HET/YIG Driver, .01 - 2 GHz, 6609A (660-D-8007-4)

CAPACITORS					
REF. DES.	DESCRIPTION	WILTRON PART NO.			
C1	Monolithic, .1 μF	230-37	C6	Monolithic, .1 μF	230-37
C2	Monolithic, .1 μF	230-37	C7	Tantalum, 35V, 6.8 μF	250-41
C3	Tantalum, 35V, 6.8 μF	250-41	C8	Monolithic, .1 μF	230-37
C4	Monolithic, .1 μF	230-37	C9	Ceramic, .01 μF	230-11
C5	Tantalum, 35V, 6.8 μF	250-41	C10	Ceramic, .001 μF	230-30
			C11	Tantalum, 1 μF, 35V	250-19
			C12	Tantalum, 1 μF, 35V	250-19
			C13	Monolithic, 1 μF	230-41
			C14	Monolithic, .1 μF	230-37
			C15	Mica, 300 pF	220-300

C16	Tantalum, 35V, 6.8 μ F	250-41
C18	Ceramic, .01 μ F	230-11
C19	Tantalum, 35V, 6.8 μ F	250-41
C21	Mica, 8.2 pF	221-8.2
C22	Mica, 820 pF	220-820
C23	Ceramic, .01 μ F	230-11
C24	Ceramic, .01 μ F	230-11
C25	Ceramic, .01 μ F	230-11

DIODES

REF. DES.	DESCRIPTION	WILTRON PART NO.
CR1	Silicon, 1N4446	10-1N4446
CR2	Silicon, 1N4446	10-1N4446
CR3	Silicon, 1N4446	10-1N4446
CR4	Silicon, SI2	10-SI2
CR5	Zener, 24V, 1W, 1N4749A	10-1N4749A
CR6	Silicon, 1N4446	10-1N4446
CR7	Silicon, 1N4446	10-1N4446
CR8	Zener, 6.8V, 1W, 1N4736A	10-1N4736A
CR9	Silicon, 1N4446	10-1N4446
CR10	Silicon, 1N4446	10-1N4446
CR11	Silicon, 1N4446	10-1N4446

TRANSISTORS

REF. DES.	DESCRIPTION	WILTRON PART NO.
Q1	PNP, MPSA92	20-MPSA92
Q2	PNP, MPSA92	20-MPSA92
Q3	NPN, 2N2222A	20-2N2222A
Q4	PNP, 2N2907A	20-2N2907A
Q5	NPN, 2N2222A	20-2N2222A
Q6	NPN, 2N3694	20-2N3694
Q7	NPN, MPSU04	20-MPSU04
Q8	PNP, 2N2907A	20-2N2907A
Q9	NPN, 2N2222A	20-2N2222A

RESISTORS

REF. DES.	DESCRIPTION	WILTRON PART NO.
R1	Variable, 1-Turn, 20 k Ω	156-20K
R2	MF, 1/4W, 1%, 61.9 k Ω	110-61.9k-1
R3	Variable, 10-Turn 1 k Ω	157-1k
R4	MF, 1/4W, 1%, 11 k Ω	110-11k-1
R5	MF, 1/4W, 1%, 5.11 k Ω	110-5.11k-1
R6	MF, 1/4W, 1%, 5.11 Ω	110-5.11-1
R7	Variable, 10-Turn, 1 k Ω	157-1k
R8	MF, 1/4W, 1%, 11 k Ω	110-11k-1
R9	Variable, 10-Turn, 20 k Ω	157-20k
R10	MF, 1/4W, 1%, 23.7 k Ω	110-23.7k-1
R11	MF, 1/4W, 1%, 511 Ω	110-511-1
R12	MF, 1/4W, 1%, 1 k Ω	110-1k-1
R13	MF, 1/4W, 1%, 9.09 k Ω	110-9.09k-1
R14	MF, 1/4W, 1%, 1.10 k Ω	110-1.10k-1
R15	WW, 5W, 5 Ω	131-3
R16	MF, 1/4W, 1%, 511 Ω	110-511-1

R17	MF, 1/4W, 1%, 5.11 k Ω	110-5.11k-1
R18	MF, 1/4W, 1%, 5.11 k Ω	110-5.11k-1
R19	MF, 1/4W, 1%, 1 k Ω	110-1k-1
R20	MF, 1/4W, 1%, 10 k Ω	110-10k-1
R21	MF, 1/4W, 1%, 23.7 k Ω	110-23.7k-1
R22	MF, 1/4W, 1%, 1 k Ω	110-1k-1
R23	MF, 1/4W, 1%, 121 Ω	110-121-1
R24	MF, 1/4W, 1%, 1 k Ω	110-1k-1
R25	MF, 1/4W, 1%, 7.5 k Ω	110-7.5k-1
R26	MF, 1/4W, 1%, 5.11 Ω	110-5.11-1
R27	MF, 1/4W, 1%, 5.11 k Ω	110-5.11k-1
R41	MF, 1/4W, 1%, 10 k Ω	110-10k-1
R42	MF, 1/4W, 1%, 15 k Ω	110-15k-1
R43	MF, 1/4W, 1%, 11 k Ω	110-11k-1
R44	MF, 1/4W, 1%, 3.24 k Ω	110-3.24k-1
R45	MF, 1/4W, 1%, 3.24 k Ω	110-3.24k-1
R46	MF, 1/4W, 1%, 1 k Ω	110-1k-1
R47	MF, 1/4W, 1%, 511 Ω	110-511-1
R48	MF, 1/4W, 1%, 5.11 Ω	110-5.11-1
R49	MF, 1/4W, 1%, 5.11 Ω	110-5.11-1
R50	MF, 1/4W, 1%, 2.74 k Ω	110-2.74k-1
R51	MF, 1/4W, 1%, 15 k Ω	110-15k-1
R66	Variable, 1-Turn, 500 k Ω	156-500k
R67	MF, 1/4W, 1%, 20 k Ω	110-20k-1
R70	MF, 1/4W, 1%, 15 k Ω	110-15k-1
R71	MF, 1/4W, 1%, 1.30 k Ω	110-1.30k-1
R72	MF, 1/4W, 1%, 8.87 k Ω	110-8.87k-1
R73	MF, 1/4W, 1%, 3.40 k Ω	110-3.40k-1
R74	MF, 1/4W, 1%, 5.11 k Ω	110-5.11k-1
R75	MF, 1/4W, 1%, 301 Ω	110-301-1
R76	MF, 1/4W, 1%, 1.21 k Ω	110-1.21k-1
R77	MF, 1/4W, 1%, 17.8 k Ω	110-17.8k-1
R78	MF, 1/4W, 1%, 511 Ω	110-511-1
R79	MF, 1/4W, 1%, 10 k Ω	110-10k-1
R80	MF, 1/4W, 1%, 10 k Ω	110-10k-1
R81	MF, 1/4W, 1%, 23.7 k Ω	110-23.7k-1
R82	MF, 1/4W, 1%, 2 k Ω	110-2k-1
R88	Variable, 1-Turn, 20 Ω	156-20
R89	MF, 1/4W, 1%, 15 k Ω	110-15k-1

INTEGRATED CIRCUITS

REF. DES.	DESCRIPTION	WILTRON PART NO.
U4	Op-Amp, OP05	54-87
U5	2k x 8 EPROM, 2716	Not Field-Replaceable
U8	Dual Op-Amp, TL072	54-53
U10	Input NAND Gate, 74LS10	54-42

MISCELLANEOUS

REF. DES.	DESCRIPTION	WILTRON PART NO.
---	Ejector, P.C. Board	553-96
TP1	Pin, Test Point	706-44
thru	Relay, 2 Form C	690-28
TP5	Socket, I.C., 24-Pin	553-67
K1		

Table 6-7. A6 HET/YIG Driver, 2-8 GHz, 6617A (660-D-8007-6)

<u>CAPACITORS</u>			<u>RESISTORS</u>		
REF. DES.	DESCRIPTION	WILTRON PART NO.	REF. DES.	DESCRIPTION	WILTRON PART NO.
C1	Monolithic, .1 μ F	230-37	R1	Variable, 1-Turn, 20 k Ω	156-20K
C2	Monolithic, .1 μ F	230-37	R2	MF, 1/4W, 1%, 61.9 k Ω	110-61.9k-1
C3	Tantalum, 35V, 6.8 μ F	250-41A	R3	Variable, 10-Turn 1 k Ω	157-1k
C4	Monolithic, .1 μ F	230-37	R4	MF, 1/4W, 1%, 11 k Ω	110-11k-1
C5	Tantalum, 35V, 6.8 μ F	250-41A	R5	Variable, 10-Turn, 50 k Ω	157-50k
C6	Monolithic, .1 μ F	230-37	R6	CC, 1/4W, 5%, 3.6 M Ω	101-3.6M-5
C7	Tantalum, 35V, 6.8 μ F	250-41A	R7	Variable, 10-Turn, 1 k Ω	157-1k
C8	Monolithic, .1 μ F	230-37	R8	MF, 1/4W, 1%, 11 k Ω	110-11k-1
C9	Ceramic, .01 μ F	230-11	R9	Variable, 10-Turn, 20 k Ω	157-20k
C10	Ceramic, .001 μ F	230-30	R10	MF, 1/4W, 1%, 100 k Ω	110-100k-1
C11	Tantalum, 1 μ F, 35V	250-19	R11	MF, 1/4W, 1%, 100 k Ω	110-100k-1
C12	Tantalum, 1 μ F, 35V	250-19	R12	Variable, 10-Turn, 5 k Ω	157-5k
C13	Monolithic, 1 μ F	230-41	R13	MF, 1/4W, 1%, 56.3 k Ω	110-56.3k-1
C14	Monolithic, .1 μ F	230-37	R14	MF, 1/4W, 1%, 4.22 k Ω	110-4.22k-1
C15	Mica, 300 pF	220-300	R15	WW, 5W, 5 Ω	131-3
C16	Tantalum, 35V, 6.8 μ F	250-41A	R16	MF, 1/4W, 1%, 100 k Ω	110-100k-1
C17	Ceramic, .001 μ F	230-30	R17	MF, 1/4W, 1%, 3.24 k Ω	110-3.24k-1
C18	Ceramic, .01 μ F	230-11	R18	MF, 1/4W, 1%, 10 k Ω	110-10k-1
C19	Tantalum, 35V, 4.7 μ F	250-39	R19	MF, 1/4W, 1%, 10 k Ω	110-10k-1
C21	Mica, 8.2 pF	221-8.2	R20	MF, 1/4W, 1%, 10 k Ω	110-10k-1
C22	Ceramic, .01 μ F	230-11	R21	MF, 1/4W, 1%, 23.7 k Ω	110-23.7k-1
C23	Ceramic, .01 μ F	230-11	R22	MF, 1/4W, 1%, 1 k Ω	110-1k-1
C24	Ceramic, .01 μ F	230-11	R23	MF, 1/4W, 1%, 121 Ω	110-121-1
C25	Ceramic, .01 μ F	230-11	R24	MF, 1/4W, 1%, 1 k Ω	110-1k-1
C26	Monolithic, .1 μ F	230-37	R25	MF, 1/4W, 1%, 7.5 k Ω	110-7.5k-1
			R26	MF, 1/4W, 1%, 5.11 Ω	110-5.11-1
			R27	MF, 1/4W, 1%, 5.11 k Ω	110-5.11k-1
			R28	MF, 1/4W, 1%, 18.7 k Ω	110-18.7k-1
			R29	MF, 1/4W, 1%, 562 k Ω	110-562k-1
			R30	MF, 1/4W, 1%, 18.7 k Ω	110-18.7k-1
			R31	MF, 1/4W, 1%, 18.7 k Ω	110-18.7k-1
			R32	MF, 1/4W, 1%, 18.7 k Ω	110-18.7k-1
			R33	MF, 1/4W, 1%, 18.7 k Ω	110-18.7k-1
			R34	MF, 1/4W, 1%, 18.7 k Ω	110-18.7k-1
			R35	MF, 1/4W, 1%, 562 k Ω	110-562k-1
			R36	Variable, 10-Turn, 2 k Ω	157-2k
			R37	MF, 1/4W, 1%, 20 k Ω	110-20k-1
			R38	Variable, 10-Turn, 50 k Ω	157-50k
			R39	MF, 1/4W, 1%, 205 k Ω	110-205k-1
			R40	MF, 1/4W, 1%, 75 k Ω	110-75k-1
			R41	MF, 1/4W, 1%, 10 k Ω	110-10k-1
			R42	MF, 1/4W, 1%, 15 k Ω	110-15k-1
			R43	MF, 1/4W, 1%, 11 k Ω	110-11k-1
			R44	MF, 1/4W, 1%, 3.24 k Ω	110-3.24k-1
			R45	MF, 1/4W, 1%, 3.24 k Ω	110-3.24k-1
			R46	MF, 1/4W, 1%, 1 k Ω	110-1k-1
			R47	MF, 1/4W, 1%, 511 Ω	110-511-1
			R48	MF, 1/4W, 1%, 5.11 Ω	110-5.11-1
			R49	MF, 1/4W, 1%, 5.11 Ω	110-5.11-1
			R50	MF, 1/4W, 1%, 2.74 k Ω	110-2.74k-1
			R51	MF, 1/4W, 1%, 10 k Ω	110-10k-1
			R52	MF, 1/4W, 1%, 750 k Ω	110-750k-1
			R53	MF, 1/4W, 1%, 14.7 k Ω	110-14.7k-1
			R54	MF, 1/4W, 1%, 10 k Ω	110-10k-1
			R55	MF, 1/4W, 1%, 750 k Ω	110-750k-1
			R56	MF, 1/4W, 1%, 14.7 k Ω	110-14.7k-1
			R57	MF, 1/4W, 1%, 5.11 Ω	110-5.11-1
			R58	Variable, 10-Turn, 500 Ω	157-500
			R59	MF, 1/4W, 1%, 2 k Ω	110-2k-1
			R60	MF, 1/4W, 1%, 10 k Ω	110-10k-1
			R61	MF, 1/4W, 1%, 750 k Ω	110-750k-1
			R62	MF, 1/4W, 1%, 14.7 k Ω	110-14.7k-1

<u>DIODES</u>		
REF. DES.	DESCRIPTION	WILTRON PART NO.
CR1	Silicon, 1N4446	10-1N4446
CR2	Silicon, 1N4446	10-1N4446
CR3	Silicon, 1N4446	10-1N4446
CR4	Silicon, SI2	10-SI2
CR5	Zener, 24V, 1W, 1N4749A	10-1N4749A
CR6	Silicon, 1N4446	10-1N4446
CR7	Silicon, 1N4446	10-1N4446
CR8	Zener, 6.8V, 1W, 1N4736A	10-1N4736A
CR9	Silicon, 1N4446	10-1N4446
CR10	Silicon, 1N4446	10-1N4446
CR11	Silicon, 1N4446	10-1N4446

<u>TRANSISTORS</u>		
REF. DES.	DESCRIPTION	WILTRON PART NO.
Q1	PNP, MPSA92	20-MPSA92
Q2	PNP, MPSA92	20-MPSA92
Q3	PNP, 2N2907A	20-2N2907A
Q4	NPN, 2N2222A	20-2N2222A
Q5	PNP, 2N2907A	20-2N2907A
Q6	NPN, 2N3694	20-2N3694
Q7	NPN, MPSU04	20-MPSU04
Q8	PNP, 2N2907A	20-2N2907A
Q9	NPN, 2N2222A	20-2N2222A

R63	MF, 1/4W, 1%, 6.49 kΩ	110-6.49k-1
R64	MF, 1/4W, 1%, 2 kΩ	110-2k-1
R65	Variable, 10-Turn, 500Ω	157-500
R66	Variable, 1-Turn, 500 kΩ	156-500k
R67	MF, 1/4W, 1%, 20 kΩ	110-20k-1
R68	MF, 1/4W, 1%, 10 kΩ	110-10k-1
R69	MF, 1/4W, 1%, 10 kΩ	110-10k-1
R70	MF, 1/4W, 1%, 15 kΩ	110-15k-1
R71	MF, 1/4W, 1%, 1.30 kΩ	110-1.30k-1
R72	MF, 1/4W, 1%, 8.87 kΩ	110-8.87k-1
R73	MF, 1/4W, 1%, 3.40 kΩ	110-3.40k-1
R74	MF, 1/4W, 1%, 5.11 kΩ	110-5.11k-1
R75	MF, 1/4W, 1%, 301Ω	110-301-1
R76	MF, 1/4W, 1%, 1.21 kΩ	110-1.21k-1
R77	MF, 1/4W, 1%, 17.8 kΩ	110-17.8k-1
R78	MF, 1/4W, 1%, 511Ω	110-511-1
R79	MF, 1/4W, 1%, 10 kΩ	110-10k-1
R80	MF, 1/4W, 1%, 10 kΩ	110-10k-1
R81	MF, 1/4W, 1%, 110 kΩ	110-110k-1
R82	MF, 1/4W, 1%, 2 kΩ	110-2k-1
R83	MF, 1/4W, 1%, 5.11 kΩ	110-5.11k-1
R84	MF, 1/4W, 1%, 1 MΩ	110-1M-1
R85	MF, 1/4W, 1%, 100 kΩ	110-100k-1
R86	MF, 1/4W, 1%, 5.11Ω	110-5.11-1
R87	MF, 1/4W, 1%, 5.11 kΩ	110-5.11k-1
R88	Variable, 1-Turn, 20Ω	156-20
R89	MF, 1/4W, 1%, 14.7 kΩ	110-14.7k-1
R91	MF, 1/4W, 1%, 20 kΩ	110-20k-1
R92	MF, 1/4W, 1%, 511Ω	110-511-1
R93	MF, 1/4W, 1%, 511Ω	110-511-1
R94	MF, 1/4W, 1%, 5.11 kΩ	110-5.11k-1
R95	MF, 1/4W, 1%, 5.11 kΩ	110-5.11k-1
R96	MF, 1/4W, 1%, 1 kΩ	110-1k-1

R97	MF, 1/4W, 1%, 15 kΩ	110-15k-1
R98	MF, 1/4W, 1%, 10 kΩ	110-10k-1
R99	MF, 1/4W, 1%, 750 kΩ	110-750k-1
R100	MF, 1/4W, 1%, 14.7 kΩ	110-14.7k-1

INTEGRATED CIRCUITS

REF. DES.	DESCRIPTION	WILTRON PART NO.
U1	Quad EX-OR Gate, 74LS86	54-125
U2	Quad Op Amp, TL074	54-132
U3	Quad Analog Switch, LF13201	54-20
U4	Op-Amp, OP05	54-87
U5	2k x 8 EPROM	Not Field-Replaceable
U7	Dual Analog Switch, DG200	50-DG200BA
U8	Dual Op-Amp, TL072	54-53
U9	Quad Volt Comparator, MC3302P	54-MC3302P
U10	Input NAND Gate, 74LS10	54-42

MISCELLANEOUS

REF. DES.	DESCRIPTION	WILTRON PART NO.
---	Ejector, P.C. Board	553-96
TP1	thru	
TP5	Pin, Test Point	706-44
K1	Relay, 2 Form C	690-28
---	Socket, I.C., 24-Pin	553-67

Table 6-8. A6 HET/YIG Driver, 2-8 GHz, 6621A/6637A/6638A/6647A/6648A (660-D-8007-3, -5, -99-91)

CAPACITORS			DIODES		
REF. DES.	DESCRIPTION	WILTRON PART NO.	REF. DES.	DESCRIPTION	WILTRON PART NO.
C1	Monolithic, .1 μF	230-37	CR1	Silicon, 1N4446	10-1N4446
C2	Monolithic, .1 μF	230-37	CR2	Silicon, 1N4446	10-1N4446
C3	Tantalum, 35V, 6.8 μF	250-41	CR3	Silicon, 1N4446	10-1N4446
C4	Monolithic, .1 μF	230-37	CR4	Silicon, SI2	10-SI2
C5	Tantalum, 35V, 6.8 μF	250-41	CR5	Zener, 24V, 1W, 1N4749A	10-1N4749A
C6	Monolithic, .1 μF	230-37	CR6	Silicon, 1N4446	10-1N4446
C7	Tantalum, 35V, 6.8 μF	250-41	CR7	Silicon, 1N4446	10-1N4446
C8	Monolithic, .1 μF	230-37	CR8	Zener, 6.8V, 1W, 1N4736A	10-1N4736A
C9	Ceramic, .01 μF	230-11	CR9	Silicon, 1N4446	10-1N4446
C10	Ceramic, .001 μF	230-30	CR10	Silicon, 1N4446	10-1N4446
C11	Tantalum, 1 μF, 35V	250-19	CR11	Silicon, 1N4446	10-1N4446
C12	Tantalum, 1 μF, 35V	250-19			
C13	Monolithic, 1 μF	230-41			
C14	Monolithic, .1 μF	230-37			
C15	Mica, 300 pF	220-300			
C16	Tantalum, 35V, 6.8 μF	250-41			
C18	Ceramic, .01 μF	230-11			
C19	Tantalum, 35V, 6.8 μF	250-41			
C21	Mica, 8.2 pF	221-8.2			
C22	Mica, 820 pF	220-820			
C23	Ceramic, .01 μF	230-11			
C24	Ceramic, .01 μF	230-11			
C25	Ceramic, .01 μF	230-11			

TRANSISTORS		
REF. DES.	DESCRIPTION	WILTRON PART NO.
Q1	PNP, MPSA92	20-MPSA92
Q2	PNP, MPSA92	20-MPSA92
Q3	PNP, 2N2907A	20-2N2907A
Q4	NPN, 2N2222A	20-2N2222A
Q5	PNP, 2N2907A	20-2N2907A
Q6	NPN, 2N3694	20-2N3694

Q7	NPN, MPSU04	20-MPSU04
Q8	PNP, 2N2907A	20-2N2907A
Q9	NPN, 2N2222A	20-2N2222A

RESISTORS

REF. DES.	DESCRIPTION	WILTRON PART NO.
R1	Variable, 1-Turn, 20 kΩ	156-20k
R2	MF, 1/4W, 1%, 61.9 kΩ	110-61.9k-1
R3	Variable, 10-Turn 1 kΩ	157-1k
R4	MF, 1/4W, 1%, 11 kΩ	110-11k-1
R5	MF, 1/4W, 1%, 5.11 kΩ	110-5.11k-1
R6	CC, 1/4W, 5%, 3.6 MΩ	101-3.6M-5
R7	Variable, 10-Turn, 1 kΩ	157-1k
R8	MF, 1/4W, 1%, 11 kΩ	110-11k-1
R9	Variable, 10-Turn, 200 kΩ	157-200k
R10	MF, 1/4W, 1%, 205 kΩ	110-205k-1
R11	MF, 1/4W, 1%, 100 kΩ	110-100k-1
R12	Variable, 10-Turn, 20 kΩ	157-20k
R13	MF, 1/4W, 1%, 75 kΩ	110-75k-1
R14 ¹	MF, 1/4W, 1%, 9.76 kΩ	110-9.76k-1
R14 ²	MF, 1/4W, 1%, 10.2k	110-10.2k-1
R14 ³	MF, 1/4W, 1%, 6.65k	110-6.65k-1
R15	WW, 5W, 5Ω	131-3
R16	MF, 1/4W, 1%, 100 kΩ	110-100k-1
R17 ¹	MF, 1/4W, 1%, 3.24 kΩ	110-3.24k-1
R17 ²	MF, 1/4W, 1%, 3.16k	110-3.16k-1
R17 ³	MF, 1/4W, 1%, 3.24k	110-3.24k-1
R18	MF, 1/4W, 1%, 10 kΩ	110-10k-1
R19	MF, 1/4W, 1%, 10 kΩ	110-10k-1
R20	MF, 1/4W, 1%, 10 kΩ	110-10k-1
R21	MF, 1/4W, 1%, 23.7 kΩ	110-23.7k-1
R22	MF, 1/4W, 1%, 1 kΩ	110-1k-1
R23	MF, 1/4W, 1%, 121Ω	110-121-1
R24	MF, 1/4W, 1%, 1 kΩ	110-1k-1
R25	MF, 1/4W, 1%, 7.5 kΩ	110-7.5k-1
R26	MF, 1/4W, 1%, 5.11Ω	110-5.11-1
R27	MF, 1/4W, 1%, 5.11 kΩ	110-5.11k-1
R28	MF, 1/4W, 1%, 18.7 kΩ	110-18.7k-1
R29 ¹	MF, 1/4W, 1%, 536 kΩ	110-536k-1
R29 ²	MF, 1/4W, 1%, 526Ω	110-526-1
R30	MF, 1/4W, 1%, 18.7 kΩ	110-18.7k-1
R31	MF, 1/4W, 1%, 18.7 kΩ	110-18.7k-1
R32	MF, 1/4W, 1%, 18.7 kΩ	110-18.7k-1
R33	MF, 1/4W, 1%, 18.7 kΩ	110-18.7k-1
R34	MF, 1/4W, 1%, 18.7 kΩ	110-18.7k-1
R35 ¹	MF, 1/4W, 1%, 536 kΩ	110-536k-1
R35 ²	MF, 1/4W, 1%, 526Ω	110-526-1
R36	Variable, 10-Turn, 2 kΩ	157-2k
R37	MF, 1/4W, 1%, 20 kΩ	110-20k-1
R38	Variable, 10-Turn, 50 kΩ	157-50k
R39	MF, 1/4W, 1%, 205 kΩ	110-205k-1
R40	MF, 1/4W, 1%, 75 kΩ	110-75k-1
R41	MF, 1/4W, 1%, 10 kΩ	110-10k-1
R42	MF, 1/4W, 1%, 15 kΩ	110-15k-1
R43	MF, 1/4W, 1%, 11 kΩ	110-11k-1
R44	MF, 1/4W, 1%, 3.24 kΩ	110-3.24k-1
R45	MF, 1/4W, 1%, 3.24 kΩ	110-3.24k-1
R46	MF, 1/4W, 1%, 1 kΩ	110-1k-1
R47	MF, 1/4W, 1%, 511Ω	110-511-1
R48	MF, 1/4W, 1%, 5.11Ω	110-5.11-1
R49	MF, 1/4W, 1%, 5.11Ω	110-5.11-1
R50	MF, 1/4W, 1%, 2.74 kΩ	110-2.74k-1
R51	MF, 1/4W, 1%, 10 kΩ	110-10k-1

¹Used on 660-D-8007-3 assembly.

²Used on 660-D-8007-5 assembly.

³Used on 660-D-8007-99-91 assembly.

R52	MF, 1/4W, 1%, 750 kΩ	110-750k-1
R53	MF, 1/4W, 1%, 14.7 kΩ	110-14.7k-1
R54	MF, 1/4W, 1%, 10 kΩ	110-10k-1
R55	MF, 1/4W, 1%, 750 kΩ	110-750k-1
R56	MF, 1/4W, 1%, 14.7 kΩ	110-14.7k-1
R57 ¹	MF, 1/4W, 1%, 2.74 kΩ	110-2.74k-1
R57 ²	MF, 1/4W, 1%, 3.16k	110-3.16k-1
R57 ³	MF, 1/4W, 1%, 2.74k	110-2.74k-1
R58	Variable, 10-Turn, 500Ω	157-500
R59	MF, 1/4W, 1%, 2 kΩ	110-2k-1
R60	MF, 1/4W, 1%, 10 kΩ	110-10k-1
R61	MF, 1/4W, 1%, 750 kΩ	110-750k-1
R62	MF, 1/4W, 1%, 14.7 kΩ	110-14.7k-1
R63 ¹	MF, 1/4W, 1%, 18.2 kΩ	110-18.2k-1
R63 ²	MF, 1/4W, 1%, 20k	110-20k-1
R64	MF, 1/4W, 1%, 2 kΩ	110-2k-1
R65	Variable, 10-Turn, 500Ω	157-500
R66	Variable, 1-Turn, 500 kΩ	156-500k
R67	MF, 1/4W, 1%, 20 kΩ	110-20k-1
R68	MF, 1/4W, 1%, 10 kΩ	110-10k-1
R69	MF, 1/4W, 1%, 10 kΩ	110-10k-1
R70	MF, 1/4W, 1%, 15 kΩ	110-15k-1
R71	MF, 1/4W, 1%, 1.30 kΩ	110-1.30k-1
R72	MF, 1/4W, 1%, 8.87 kΩ	110-8.87k-1
R73	MF, 1/4W, 1%, 3.40 kΩ	110-3.40k-1
R74	MF, 1/4W, 1%, 5.11 kΩ	110-5.11k-1
R75	MF, 1/4W, 1%, 301Ω	110-301-1
R76	MF, 1/4W, 1%, 1.21 kΩ	110-1.21k-1
R77	MF, 1/4W, 1%, 17.8 kΩ	110-17.8k-1
R78	MF, 1/4W, 1%, 511Ω	110-511-1
R79	MF, 1/4W, 1%, 10 kΩ	110-10k-1
R80	MF, 1/4W, 1%, 10 kΩ	110-10k-1
R81	MF, 1/4W, 1%, 205 kΩ	110-205k-1
R82	MF, 1/4W, 1%, 2 kΩ	110-2k-1
R83	MF, 1/4W, 1%, 5.11 kΩ	110-5.11k-1
R84	MF, 1/4W, 1%, 1 MΩ	110-1M-1
R85	Variable, 1-Turn, 100k	156-100k
R86	MF, 1/4W, 1%, 5.11Ω	110-5.11-1
R87	MF, 1/4W, 1%, 5.11 kΩ	110-5.11k-1
R88	Variable, 1-Turn, 20Ω	156-20
R89	MF, 1/4W, 1%, 15 kΩ	110-15k-1
R90	MF, 1/4W, 1%, 33.2 kΩ	110-33.2k-1
R90 ³	MF, 1/4W, 1%, 31.6k	110-31.6k-1
R91	MF, 1/4W, 1%, 33.2 kΩ	110-33.2k-1
R91 ³	MF, 1/4W, 1%, 20k	110-20k-1
R92	MF, 1/4W, 1%, 511Ω	110-511-1
R93	MF, 1/4W, 1%, 511Ω	110-511-1
R94	MF, 1/4W, 1%, 5.11 kΩ	110-5.11k-1
R95	MF, 1/4W, 1%, 5.11 kΩ	110-5.11k-1
R96	MF, 1/4W, 1%, 1 kΩ	110-1k-1
R97	MF, 1/4W, 1%, 15 kΩ	110-15k-1
R98	MF, 1/4W, 1%, 10 kΩ	110-10k-1
R99	MF, 1/4W, 1%, 750 kΩ	110-750k-1
R100	MF, 1/4W, 1%, 14.7 kΩ	110-14.7k-1

INTEGRATED CIRCUITS

REF. DES.	DESCRIPTION	WILTRON PART NO.
U1	Quad EX-OR Gate, 74LS86	54-125
U2	Quad Op Amp, TL074	54-132
U3	Quad Analog Switch, LF13201	54-20
U4	Op-Amp, OP05	54-87
U5	2k x 8 EPROM, 2716	Not Field-Replaceable
U7	Dual Analog Switch, DG200	50-DG200BA
U8	Dual Op-Amp, TL072	54-53
U9	Quad Volt Comparator, MC3302P	54-MC3302P
U10	Input NAND Gate, 74LS10	54-42

MISCELLANEOUS

REF. DES.	DESCRIPTION	WILTRON PART NO.
---	Ejector, P.C. Board	553-96

TP1 thru TP5	Pin, Test Point	706-44
K1	Relay, 2 Form C	690-28
---	Socket, I.C., 24-Pin	553-67

Table 6-9. A6 YIG Driver, 2-8 GHz, 6621A-40/6637A-40 (660-D-12868-3, -99-91)

<u>CAPACITORS</u>			Q8	PNP, 2N2907A	20-2N2907A
REF. DES.	DESCRIPTION	WILTRON PART NO.	Q9	NPN, 2N2222A	20-2N2222A
C1	Monolithic, .1 μ F	230-37	<u>RESISTORS</u>		
C2	Monolithic, .1 μ F	230-37	REF. DES.	DESCRIPTION	WILTRON PART NO.
C3	Tantalum, 35V, 6.8 μ F	250-41	R1	Variable, 1-Turn, 20 k Ω	156-20k
C4	Monolithic, .1 μ F	230-37	R2	MF, 1/4W, 1%, 61.9 k Ω	110-61.9k-1
C5	Tantalum, 35V, 6.8 μ F	250-41	R3	Variable, 10-Turn, 1 k Ω	157-1k
C6	Monolithic, .1 μ F	230-37	R4	MF, 1/4W, 1%, 11 k Ω	110-11k-1
C7	Tantalum, 35V, 6.8 μ F	250-41	R5	MF, 1/4W, 1%, 50 k Ω	110-50k-1
C8	Monolithic, .1 μ F	230-37	R6	CC, 1/4W, 5%, 3.6 M Ω	101-3.6M-5
C9	Ceramic, .01 μ F	230-11	R7	Variable, 10-Turn, 1 k Ω	157-1k
C10	Ceramic, .001 μ F	230-30	R8	MF, 1/4W, 1%, 11 k Ω	110-11k-1
C11	Tantalum, 1 μ F, 35V	250-19	R9	Variable, 10-Turn, 200 k Ω	157-200k
C12	Tantalum, 1 μ F, 35V	250-19	R10	MF, 1/4W, 1%, 205 k Ω	110-205k-1
C13	Monolithic, 1 μ F	230-41	R11	MF, 1/4W, 1%, 100 k Ω	110-100k-1
C14	Monolithic, .1 μ F	230-37	R12	Variable, 10-Turn, 20 k Ω	157-20k
C15	Mica, 300 pF	220-300	R13	MF, 1/4W, 1%, 75 k Ω	110-75k-1
C16	Tantalum, 35V, 6.8 μ F	250-41	R14	MF, 1/4W, 1%, 9.76 k Ω	110-9.76k-1
C17	Ceramic, .001 μ F	230-30	R14 ¹	MF, 1/4W, 1%, 6.65k	110-6.65k-1
C18	Ceramic, .01 μ F	230-11	R15	WW, 5W, 5 Ω	131-3
C19	Tantalum, 35V, 6.8 μ F	250-41	R16	MF, 1/4W, 1%, 100 k Ω	110-100k-1
C21	Mica, 8.2 pF	221-8.2	R17	MF, 1/4W, 1%, 3.24 k Ω	110-3.24k-1
C22	Mica, 820 pF	220-820	R18	MF, 1/4W, 1%, 10 k Ω	110-10k-1
C23	Ceramic, .01 μ F	230-11	R19	MF, 1/4W, 1%, 10 k Ω	110-10k-1
C24	Ceramic, .01 μ F	230-11	R20	MF, 1/4W, 1%, 10 k Ω	110-10k-1
C25	Ceramic, .01 μ F	230-11	R21	MF, 1/4W, 1%, 23.7 k Ω	110-23.7k-1
C26	Monolithic, .1 μ F	230-37	R22	MF, 1/4W, 1%, 1 k Ω	110-1k-1
<u>DIODES</u>			R23	MF, 1/4W, 1%, 121 Ω	110-121-1
REF. DES.	DESCRIPTION	WILTRON PART NO.	R24	MF, 1/4W, 1%, 1 k Ω	110-1k-1
CR1	Silicon, 1N4446	10-1N4446	R25	MF, 1/4W, 1%, 7.5 k Ω	110-7.5k-1
CR2	Silicon, 1N4446	10-1N4446	R26	MF, 1/4W, 1%, 5.11 Ω	110-5.11-1
CR3	Silicon, 1N4446	10-1N4446	R27	MF, 1/4W, 1%, 5.11 k Ω	110-5.11k-1
CR4	Silicon, SI2	10-SI2	R28	MF, 1/4W, 1%, 18.7 k Ω	110-18.7k-1
CR5	Zener, 24V, 1W, 1N4749A	10-1N4749A	R29	MF, 1/4W, 1%, 536 k Ω	110-536k-1
CR6	Silicon, 1N4446	10-1N4446	R30	MF, 1/4W, 1%, 18.7 k Ω	110-18.7k-1
CR7	Silicon, 1N4446	10-1N4446	R31	MF, 1/4W, 1%, 18.7 k Ω	110-18.7k-1
CR8	Zener, 6.8V, 1W, 1N4736A	10-1N4736A	R32	MF, 1/4W, 1%, 18.7 k Ω	110-18.7k-1
CR9	Silicon, 1N4446	10-1N4446	R33	MF, 1/4W, 1%, 18.7 k Ω	110-18.7k-1
CR10	Silicon, 1N4446	10-1N4446	R34	MF, 1/4W, 1%, 18.7 k Ω	110-18.7k-1
CR11	Silicon, 1N4446	10-1N4446	R35	MF, 1/4W, 1%, 536 k Ω	110-536k-1
<u>TRANSISTORS</u>			R36	Variable, 10-Turn, 2 k Ω	110-2k-1
REF. DES.	DESCRIPTION	WILTRON PART NO.	R37	MF, 1/4W, 1%, 20 k Ω	110-20k-1
Q1	PNP, MPSA92	20-MPSA92	R38	Variable, 10-Turn, 50 k Ω	110-50k-1
Q2	PNP, MPSA92	20-MPSA92	R39	MF, 1/4W, 1%, 205 k Ω	110-205k-1
Q3	PNP, 2N2907A	20-2N2907A	R40	MF, 1/4W, 1%, 75 k Ω	110-75k-1
Q4	NPN, 2N2222A	20-2N2222A	R41	MF, 1/4W, 1%, 10 k Ω	110-10k-1
Q5	PNP, 2N2907A	20-2N2907A	R42	MF, 1/4W, 1%, 9.53 k Ω	110-9.53k-1
Q6	NPN, 2N3694	20-2N3694	R43	MF, 1/4W, 1%, 11 k Ω	110-11k-1
Q7	NPN, MPSU04	20-MPSU04	R44	MF, 1/4W, 1%, 3.24 k Ω	110-3.24k-1
			R45	MF, 1/4W, 1%, 3.24 k Ω	110-3.24k-1
			R46	MF, 1/4W, 1%, 1 k Ω	110-1k-1
			R47	MF, 1/4W, 1%, 511 Ω	110-511-1
			R48	MF, 1/4W, 1%, 5.11 Ω	110-5.11-1
			R49	MF, 1/4W, 1%, 5.11 Ω	110-5.11-1
			R50	MF, 1/4W, 1%, 2.74 k Ω	110-2.74k-1
			R51	MF, 1/4W, 1%, 10 k Ω	110-10k-1

¹ Used on 660-D-12868-99-91

R52	MF, 1/4W, 1%, 750 k Ω	110-750k-1	R88	Variable, 1-Turn 20 Ω	156-20
R53	MF, 1/4W, 1%, 14.7 k Ω	110-14.7k-1	R89	MF, 1/4W, 1%, 15k	110-15k-1
R54	MF, 1/4W, 1%, 10 k Ω	110-10k-1	R90	MF, 1/4W, 1%, 33.2 k Ω	110-33.2k-1
R55	MF, 1/4W, 1%, 750 k Ω	110-750k-1	R90 ¹	MF, 1/4W, 1%, 31.6 k Ω	110-31.6k-1
R56	MF, 1/4W, 1%, 14.7 k Ω	110-14.7k-1	R91	MF, 1/4W, 1%, 33.2 k Ω	110-33.2k-1
R57	MF, 1/4W, 1%, 2.74 k Ω	110-2.74k-1	R91 ¹	MF, 1/4W, 1%, 31.6 k Ω	110-31.6k-1
R58	Variable, 10-Turn, 500 Ω	157-500	R92	MF, 1/4W, 1%, 511 Ω	110-511-1
R59	MF, 1/4W, 1%, 2 k Ω	110-2k-1	R93	MF, 1/4W, 1%, 511 Ω	110-511-1
R60	MF, 1/4W, 1%, 10 k Ω	110-10k-1	R94	Variable, 10-Turn, 20 k Ω	157-20k
R61	MF, 1/4W, 1%, 750 k Ω	110-750k-1	R95	MF, 1/4W, 1%, 5.11 Ω	110-5.11-1
R62	MF, 1/4W, 1%, 14.7 k Ω	110-14.7k-1	R96	MF, 1/4W, 1%, 10 k Ω	110-10k-1
R63	MF, 1/4W, 1%, 18.2 k Ω	110-18.2k-1	R97	MF, 1/4W, 1%, 750 k Ω	110-750k-1
R64	MF, 1/4W, 1%, 2 k Ω	110-2k-1	R98	MF, 1/4W, 1%, 14.7 k Ω	110-14.7k-1
R65	Variable, 10-Turn, 500 Ω	157-500			
R66	Variable, 1-Turn, 500 k Ω	156-500k			
R67	MF, 1/4W, 1%, 20 k Ω	110-20k-1			
R68	MF, 1/4W, 1%, 10 k Ω	110-10k-1			
R69	MF, 1/4W, 1%, 10 k Ω	110-10k-1			
R70	MF, 1/4W, 1%, 15 k Ω	110-15k-1			
R71	MF, 1/4W, 1%, 1.30 k Ω	110-1.30k-1			
R72	MF, 1/4W, 1%, 8.87 k Ω	110-8.87k-1			
R73	MF, 1/4W, 1%, 3.40 k Ω	110-3.40k-1			
R74	MF, 1/4W, 1%, 5.11 k Ω	110-5.11k-1			
R75	MF, 1/4W, 1%, 301 Ω	110-301-1			
R76	MF, 1/4W, 1%, 1.21 k Ω	110-1.21k-1			
R77	MF, 1/4W, 1%, 17.8 k Ω	110-17.8k-1			
R78	MF, 1/4W, 1%, 511 Ω	110-511-1			
R79	MF, 1/4W, 1%, 10 k Ω	110-10k-1			
R80	MF, 1/4W, 1%, 10 k Ω	110-10k-1			
R81	MF, 1/4W, 1%, 205 k Ω	110-205k-1			
R82	MF, 1/4W, 1%, 2 k Ω	110-2k-1			
R83	MF, 1/4W, 1%, 5.11 k Ω	110-5.11k-1			
R84	MF, 1/4W, 1%, 1 M Ω	110-1M-1			
R85	Variable, 1-Turn, 100 k Ω	156-100k			
R86	MF, 1/4W, 1%, 5.11 Ω	110-5.11-1			
R87	MF, 1/4W, 1%, 5.11 k Ω	110-5.11k-1			

<u>INTEGRATED CIRCUITS</u>		
REF. DES.	DESCRIPTION	WILTRON PART NO.
U4	Op-Amp, OP05	54-87
U5	2k x 8 EPROM	Not Field-Replaceable
U8	Dual Op-Amp, TL072	54-53
U10	Input NAND Gate, 74LS10	54-42

<u>MISCELLANEOUS</u>		
REF. DES.	DESCRIPTION	WILTRON PART NO.
---	Ejector, P.C. Board	553-96
TP1 thru TP5	Pin, Test Point	706-44
K1	Relay, 2 Form C	690-28
---	Socket, I.C., 24-Pin	553-67

Table 6-10. A6 YIG Driver, 18-26.5 GHz, 6642A (660-D-8190-99-98)

<u>CAPACITORS</u>			<u>DIODES</u>		
REF. DES.	DESCRIPTION	WILTRON PART NO.	REF. DES.	DESCRIPTION	WILTRON PART NO.
C1	Tantalum, 4.7 μ F	250-39	CR1	Silicon, 1N4446	10-1N4446
C2	Tantalum, 4.7 μ F	250-39	CR2	Silicon, 1N4446	10-1N4446
C3	Tantalum, 4.7 μ F	250-39	CR3	Silicon, SI2	10-SI2
C4	Disc Ceramic, .01 μ F	230-11	CR4	Zener, 24V, 1W, 1N4749A	10-1N4749A
C5	Disc Ceramic, .001 μ F	230-30	CR5	Silicon, SI2	10-SI2
C6	Tantalum, 1 μ F	250-19	CR6	Silicon, 1N4446	10-1N4446
C7	Tantalum, 1 μ F	250-19	CR7	Silicon, 1N4446	10-1N4446
C8	Monolithic, 1.0 μ F	230-41	CR8	Silicon, 1N4446	10-1N4446
C9	Mica, 300 pF	220-300	CR9	Zener, 10V, 0.4W, 1N758A	10-1N758A
C10	Monolithic, .1 μ F	230-37	CR10	Silicon, 1N4446	10-1N4446
C11	Tantalum, 6.8 μ F	250-41			
C12	Mica, 5 pF	220-5			
C13	Monolithic, .1 μ F	230-37			
C14	Disc Ceramic, .01 μ F	230-11			
C16	Monolithic, .1 μ F	230-37			
C17	Disc Ceramic, .01 μ F	230-11			
C18	Disc Ceramic, .01 μ F	230-11			
C19	Disc Ceramic, .01 μ F	230-11			
C20	Mica, 820 pF	220-820			
C21	Mica, 39 pF	220-39			

<u>TRANSISTORS</u>		
REF. DES.	DESCRIPTION	WILTRON PART NO.
Q1	PNP, MPSA92	20-MPSA92
Q2	PNP, MPSA92	20-MPSA92
Q3	NPN, 2N4249	20-2N4249
Q4	NPN, MPSU55	20-30

¹Used on 660-D-12868-99-91

Q5	NPN, 2N2222A	20-2N2222A
Q6	PNP, 2N2907A	20-2N2907A
Q7	NPN, 2N2222A	20-2N2222A
Q8	NPN, 2N2222A	20-2N2222A

RESISTORS

REF. DES.	DESCRIPTION	WILTRON PART NO.
R1	CC, 1/4W, 5%, 3.3 kΩ	101-3.3M-5
R2	Variable, 10-Turn, 50 kΩ	157-50k
R3	CC, 1/4W, 5%, 3.6 MΩ	101-3.6M-5
R4	MF, 1/8W, 1%, 61.9 kΩ	110-61.9k-1
R5	Variable, 10-Turn, 1 kΩ	157-1k
R6	MF, 1/8W, 1%, 10 kΩ	110-10k-1
R7	Variable, 10-Turn, 1 kΩ	157-1k
R8	MF, 1/8W, 1%, 20 kΩ	110-20k-1
R9	Variable, 10-Turn, 200 kΩ	157-200k
R10	MF, 1/8W, 1%, 301 kΩ	110-301k-1
R11	MF, 1/8W, 1%, 6.19 kΩ	110-6.19k-1
R12	MF, 1/8W, 1%, 20 kΩ	110-20k-1
R13	Variable, 1-Turn, 20 kΩ	156-20k
R14	MF, 1/8W, 1%, 2.61 kΩ	110-2.61k-1
R15	MF, 1/8W, 1%, 10 kΩ	110-10k-1
R16	MF, 1/8W, 1%, 10 kΩ	110-10k-1
R17	MF, 1/8W, 1%, 10 kΩ	110-10k-1
R18	MF, 1/8W, 1%, 23.7 kΩ	110-23.7k-1
R19	MF, 1/8W, 1%, 1 kΩ	110-1k-1
R20	MF, 1/8W, 1%, 121Ω	110-121-1
R21	MF, 1/8W, 1%, 1 kΩ	110-1k-1
R22	MF, 1/8W, 1%, 7.5 kΩ	110-7.5k-1
R23	MF, 1/8W, 1%, 511Ω	110-511-1
R24	MF, 1/8W, 1%, 5.11 kΩ	110-5.11k-1
R25	WW, 5W, 5Ω	131-3
R26	MF, 1/8W, 1%, 15.4 kΩ	110-15.4k-1
R27	MF, 1/8W, 1%, 649Ω	110-649-1
R28	MF, 1/8W, 1%, 6.19 kΩ	110-6.19k-1
R29	MF, 1/8W, 1%, 1.37 kΩ	110-1.37k-1
R30	MF, 1/8W, 1%, 3.83 kΩ	110-3.83k-1
R31	MF, 1/8W, 1%, 1 kΩ	110-1k-1
R32	MF, 1/8W, 1%, 1.21 kΩ	110-1.21k-1
R33	MF, 1/8W, 1%, 17.8 kΩ	110-17.8k-1
R34	Variable, 1-Turn, 500 kΩ	156-500k
R35	MF, 1/8W, 1%, 49.9 kΩ	110-49.9k-1
R36	MF, 1/8W, 1%, 5.11 kΩ	110-5.11k-1
R37	MF, 1/8W, 1%, 5.11 kΩ	110-5.11k-1
R38	MF, 1/8W, 1%, 18.7 kΩ	110-18.7k-1
R39	MF, 1/8W, 1%, 18.7 kΩ	110-18.7k-1
R40	MF, 1/8W, 1%, 10 kΩ	110-10k-1
R41	MF, 1/8W, 1%, 133 kΩ	110-133k-1
R42	Variable, 10-Turn, 50 kΩ	157-50k
R43	MF, 1/8W, 1%, 18.7 kΩ	110-18.7k-1
R44	MF, 1/8W, 1%, 18.7 kΩ	110-18.7k-1
R45	MF, 1/8W, 1%, 10 kΩ	110-10k-1
R46	MF, 1/8W, 1%, 14.7 kΩ	110-14.7k-1
R47	Variable, 10-Turn, 1 kΩ	157-1k
R48	MF, 1/8W, 1%, 11 kΩ	110-11k-1
R49	MF, 1/8W, 1%, 10 kΩ	110-10k-1
R50	MF, 1/8W, 1%, 511Ω	110-511-1
R51	MF, 1/8W, 1%, 4.99 kΩ	110-4.99k-1
R52	MF, 1/8W, 1%, 3.83 kΩ	110-3.83k-1

R53	MF, 1/8W, 1%, 1 kΩ	110-1k-1
R54	MF, 1/8W, 1%, 511Ω	110-511-1
R55	CC, 1/2W, 5%, .5Ω	102-.5-5
R56	CC, 1/2W, 5%, .5Ω	102-.5-5
R57	MF, 1/8W, 1%, 5.11Ω	110-5.11-1
R58	MF, 1/8W, 1%, 5.11Ω	110-5.11-1
R60	MF, 1/8W, 1%, 2.15 kΩ	110-2.15k-1
R61	MF, 1/8W, 1%, 511Ω	110-511-1
R62	MF, 1/8W, 1%, 511Ω	110-511-1
R63	MF, 1/8W, 1%, 10 kΩ	110-10k-1
R64	MF, 1/8W, 1%, 10 kΩ	110-10k-1
R65	MF, 1/8W, 1%, 2 kΩ	110-750k-1
R66	MF, 1/8W, 1%, 14.7 kΩ	110-14.7k-1
R67	MF, 1/8W, 1%, 5.11Ω	110-5.11-1
R68	Variable, 10-Turn, 500Ω	157-500
R69	MF, 1/8W, 1%, 2 kΩ	110-2k-1
R70	MF, 1/8W, 1%, 10 kΩ	110-10k-1
R71	MF, 1/8W, 1%, 750 kΩ	110-750k-1
R72	MF, 1/8W, 1%, 14.7 kΩ	110-14.7k-1
R73	MF, 1/8W, 1%, 10 kΩ	110-10k-1
R74	MF, 1/8W, 1%, 10 kΩ	110-10k-1
R75	MF, 1/8W, 1%, 205 kΩ	110-205k-1
R76	MF, 1/8W, 1%, 511Ω	110-511-1
R77	Variable, 1-Turn, 20Ω	156-20
R78	MF, 1/8W, 1%, 2 kΩ	110-2k-1
R79	MF, 1/8W, 1%, 14.7 kΩ	110-14.7k-1
R80	MF, 1/8W, 1%, 23.7 kΩ	110-23.7k-1
R81	MF, 1/8W, 1%, 23.7 kΩ	110-23.7k-1
R82	MF, 1/8W, 1%, 20 kΩ	110-20k-1
R83	MF, 1/8W, 1%, 20 kΩ	110-20k-1
R84	MF, 1/8W, 1%, 5.11 kΩ	110-5.11k-1
R85	MF, 1/8W, 1%, 5.11 kΩ	110-5.11k-1
R86	MF, 1/8W, 1%, 511Ω	110-511-1

INTEGRATED CIRCUITS

REF. DES.	DESCRIPTION	WILTRON PART NO.
U1	Quad Analog Switch, LF13201	54-20
U2	NAND Gate, 74LS10	54-42
U3	Op Amp, OP05	54-87
U4	Dual Op Amp, TL072	54-53
U5	256 x 4 PROM,	Not Field-Replaceable
U7	Quad Op Amp, TL074	54-132
U8	Quad Ex. OR Gate 74LS86	54-125
U9	Dual Volt. Comp., LM393	54-158

MISCELLANEOUS

REF. DES.	DESCRIPTION	WILTRON PART NO.
—	Ejector, P.C. Board	553-96
TP1 thru TP4	Pin, Test Point	706-44
K1	Relay, 2 Form C	690-28
—	Socket, I.C., 24-Pin	553-67

Table 6-11. A6 HET/YIG Driver, 2-8 GHz, 6653A/6659A (660-D-8007-7)

<u>CAPACITORS</u>			<u>RESISTORS</u>		
REF. DES.	DESCRIPTION	WILTRON PART NO.	REF. DES.	DESCRIPTION	WILTRON PART NO.
C1	Monolithic, .1 μ F	230-37	R1	Variable, 1-Turn, 20 k Ω	156-20K
C2	Monolithic, .1 μ F	230-37	R2	MF, 1/4W, 1%, 61.9 k Ω	110-61.9k-1
C3	Tantalum, 35V, 6.8 μ F	250-41	R3	Variable, 10-Turn, 1 k Ω	157-1k
C4	Monolithic, .1 μ F	230-37	R4	MF, 1/4W, 1%, 11 k Ω	110-11k-1
C5	Tantalum, 35V, 6.8 μ F	250-41	R5	Variable, 10-Turn, 50 k Ω	157-50k
C6	Monolithic, .1 μ F	230-37	R6	CC, 1/4W, 5%, 3.6 M Ω	101-3.6M-5
C7	Tantalum, 35V, 6.8 μ F	250-41	R7	Variable, 10-Turn, 1 k Ω	157-1k
C8	Monolithic, .1 μ F	230-37	R8	MF, 1/4W, 1%, 11 k Ω	110-11k-1
C9	Ceramic, .01 μ F	230-11	R9	Variable, 10-Turn, 200 k Ω	157-200k
C10	Ceramic, .001 μ F	230-30	R10	MF, 1/4W, 1%, 205 k Ω	110-205k-1
C11	Tantalum, 1 μ F, 35V	250-19	R11	MF, 1/4W, 1%, 100 k Ω	110-100k-1
C12	Tantalum, 1 μ F, 35V	250-19	R12	Variable, 10-Turn, 20 k Ω	157-20k
C13	Monolithic, 1 μ F	230-41	R13	MF, 1/4W, 1%, 110 k Ω	110-110k-1
C14	Monolithic, .1 μ F	230-37	R14	MF, 1/4W, 1%, 14.0 k Ω	110-14.0k-1
C15	Mica, 300 pF	220-300	R15	WW, 5W, 5 Ω	131-3
C16	Tantalum, 35V, 6.8 μ F	250-41	R16	MF, 1/4W, 1%, 100 k Ω	110-100k-1
C17	Ceramic, .001 μ F	230-30	R17	MF, 1/4W, 1%, 3.16 k Ω	110-3.16k-1
C18	Ceramic, .01 μ F	230-11	R18	MF, 1/4W, 1%, 10 k Ω	110-10k-1
C19	Tantalum, 35V, 6.8 μ F	250-41	R19	MF, 1/4W, 1%, 10 k Ω	110-10k-1
C21	Mica, 8.2 pF	221-8.2	R20	MF, 1/4W, 1%, 10 k Ω	110-10k-1
C22	Mica, 820 pF	220-820	R21	MF, 1/4W, 1%, 23.7 k Ω	110-23.7k-1
C23	Ceramic, .01 μ F	230-11	R22	MF, 1/4W, 1%, 1 k Ω	110-1k-1
C24	Ceramic, .01 μ F	230-11	R23	MF, 1/4W, 1%, 121 Ω	110-121-1
C25	Ceramic, .01 μ F	230-11	R24	MF, 1/4W, 1%, 1 k Ω	110-1k-1
C26	Monolithic, .1 μ F	230-37	R25	MF, 1/4W, 1%, 7.5 k Ω	110-7.5k-1
			R26	MF, 1/4W, 1%, 5.11 Ω	110-5.11-1
			R27	MF, 1/4W, 1%, 5.11 k Ω	110-5.11k-1
			R28	MF, 1/4W, 1%, 18.7 k Ω	110-18.7k-1
			R29	MF, 1/4W, 1%, 536 k Ω	110-536k-1
			R30	MF, 1/4W, 1%, 18.7 k Ω	110-18.7k-1
			R31	MF, 1/4W, 1%, 18.7 k Ω	110-18.7k-1
			R32	MF, 1/4W, 1%, 18.7 k Ω	110-18.7k-1
			R33	MF, 1/4W, 1%, 18.7 k Ω	110-18.7k-1
			R34	MF, 1/4W, 1%, 18.7 k Ω	110-18.7k-1
			R35	MF, 1/4W, 1%, 536 k Ω	110-536k-1
			R36	Variable, 10-Turn, 2 k Ω	157-2k
			R37	MF, 1/4W, 1%, 20 k Ω	110-20k-1
			R38	Variable, 10-Turn, 50 k Ω	157-50k
			R39	MF, 1/4W, 1%, 205 k Ω	110-205k-1
			R40	MF, 1/4W, 1%, 75 k Ω	110-75k-1
			R41	MF, 1/4W, 1%, 10 k Ω	110-10k-1
			R42	MF, 1/4W, 1%, 15 k Ω	110-15k-1
			R43	MF, 1/4W, 1%, 11 k Ω	110-11k-1
			R44	MF, 1/4W, 1%, 3.24 k Ω	110-3.24k-1
			R45	MF, 1/4W, 1%, 3.24 k Ω	110-3.24k-1
			R46	MF, 1/4W, 1%, 1 k Ω	110-1k-1
			R47	MF, 1/4W, 1%, 511 Ω	110-511-1
			R48	MF, 1/4W, 1%, 5.11 Ω	110-5.11-1
			R49	MF, 1/4W, 1%, 5.11 Ω	110-5.11-1
			R50	MF, 1/4W, 1%, 2.74 k Ω	110-2.74k-1
			R51	MF, 1/4W, 1%, 10 k Ω	110-10k-1
			R52	MF, 1/4W, 1%, 750 k Ω	110-750k-1
			R53	MF, 1/4W, 1%, 14.7 k Ω	110-14.7k-1
			R54	MF, 1/4W, 1%, 10 k Ω	110-10k-1
			R55	MF, 1/4W, 1%, 750 k Ω	110-750k-1
			R56	MF, 1/4W, 1%, 14.7 k Ω	110-14.7k-1
			R57	MF, 1/4W, 1%, 5.11 k Ω	110-5.11k-1
			R58	Variable, 10-Turn, 500 Ω	157-500
			R59	MF, 1/4W, 1%, 2 k Ω	110-2k-1
			R60	MF, 1/4W, 1%, 10 k Ω	110-10k-1
			R61	MF, 1/4W, 1%, 750 k Ω	110-750k-1
			R62	MF, 1/4W, 1%, 14.7 k Ω	110-14.7k-1

<u>DIODES</u>		
REF. DES.	DESCRIPTION	WILTRON PART NO.
CR1	Silicon, 1N4446	10-1N4446
CR2	Silicon, 1N4446	10-1N4446
CR3	Silicon, 1N4446	10-1N4446
CR4	Silicon, SI2	10-SI2
CR5	Zener, 24V, 1W, 1N4749A	10-1N4749A
CR6	Silicon, 1N4446	10-1N4446
CR7	Silicon, 1N4446	10-1N4446
CR8	Zener, 6.8V, 1W, 1N4736A	10-1N4736A
CR9	Silicon, 1N4446	10-1N4446
CR10	Silicon, 1N4446	10-1N4446
CR11	Silicon, 1N4446	10-1N4446

<u>TRANSISTORS</u>		
REF. DES.	DESCRIPTION	WILTRON PART NO.
Q1	PNP, MPSA92	20-MPSA92
Q2	PNP, MPSA92	20-MPSA92
Q3	PNP, 2N2907A	20-2N2907A
Q4	NPN, 2N2222A	20-2N2222A
Q5	PNP, 2N2907A	20-2N2907A
Q6	NPN, 2N3694	20-2N3694
Q7	NPN, MPSU04	20-MPSU04
Q8	PNP, 2N2907A	20-2N2907A
Q9	NPN, 2N2222A	20-2N2222A

R63	MF, 1/4W, 1%, 27.4 kΩ	110-27.4k-1
R64	MF, 1/4W, 1%, 2 kΩ	110-2k-1
R65	Variable, 10-Turn, 500Ω	157-500
R66	Variable, 1-Turn, 500 kΩ	156-500k
R67	MF, 1/4W, 1%, 20 kΩ	110-20k-1
R68	MF, 1/4W, 1%, 10 kΩ	110-10k-1
R69	MF, 1/4W, 1%, 10 kΩ	110-10k-1
R70	MF, 1/4W, 1%, 15 kΩ	110-15k-1
R71	MF, 1/4W, 1%, 1.30 kΩ	110-1.30k-1
R72	MF, 1/4W, 1%, 8.87 kΩ	110-8.87k-1
R73	MF, 1/4W, 1%, 3.40 kΩ	110-3.40k-1
R74	MF, 1/4W, 1%, 5.11 kΩ	110-5.11k-1
R75	MF, 1/4W, 1%, 301Ω	110-301-1
R76	MF, 1/4W, 1%, 1.21 kΩ	110-1.21k-1
R77	MF, 1/4W, 1%, 17.8 kΩ	110-17.8k-1
R78	MF, 1/4W, 1%, 511Ω	110-511-1
R79	MF, 1/4W, 1%, 10 kΩ	110-10k-1
R80	MF, 1/4W, 1%, 10 kΩ	110-10k-1
R81	MF, 1/4W, 1%, 205 kΩ	110-205k-1
R82	MF, 1/4W, 1%, 2 kΩ	110-2k-1
R83	MF, 1/4W, 1%, 5.11 kΩ	110-5.11k-1
R84	MF, 1/4W, 1%, 1M	110-1M-1
R85	MF, 1/4W, 1%, 100 kΩ	110-100k-1
R86	MF, 1/4W, 1%, 5.11Ω	110-5.11-1
R87	MF, 1/4W, 1%, 5.11 kΩ	110-5.11k-1
R88	Variable, 1-Turn, 20Ω	156-20
R89	MF, 1/4W, 1%, 15 kΩ	110-15k-1
R90	MF, 1/4W, 1%, 31.6 kΩ	110-31.6k-1
R91	MF, 1/4W, 1%, 20 kΩ	110-20k-1
R92	MF, 1/4W, 1%, 511Ω	110-511-1
R93	MF, 1/4W, 1%, 511Ω	110-511-1
R94	MF, 1/4W, 1%, 5.11 kΩ	110-5.11k-1
R95	MF, 1/4W, 1%, 5.11 kΩ	110-5.11k-1

R96	MF, 1/4W, 1%, 1 kΩ	110-1k-1
R97	MF, 1/4W, 1%, 15 kΩ	110-15k-1
R98	MF, 1/4W, 1%, 10 kΩ	110-10k-1
R99	MF, 1/4W, 1%, 750 kΩ	110-750k-1
R100	MF, 1/4W, 1%, 14.7 kΩ	110-14.7k-1

INTEGRATED CIRCUITS

REF. DES.	DESCRIPTION	WILTRON PART NO.
U1	Quad EX-OR Gate, 74LS86	54-125
U2	Quad Op Amp, TL074	54-132
U3	Quad Analog Switch, LF13201	54-20
U4	Op-Amp, OP05	54-87
U5	2k x 8 EPROM	Not Field-Replaceable
U7	Dual Analog Switch, DG200	50-DG200BA
U8	Dual Op-Amp, TL072	54-53
U9	Quad Volt Comparator, MC3302P	54-MC3302P
U10	Input NAND Gate, 74LS10	54-42

MISCELLANEOUS

REF. DES.	DESCRIPTION	WILTRON PART NO.
---	Ejector, P.C. Board	553-96
TP1 thru TP5	Pin, Test Point	706-44
K1	Relay, 2 Form C	690-28
---	Socket, I.C., 24-Pin	553-67

Table 6-12. A6/A7/A8 YIG Driver, 8-12.4 GHz, 6621A/6629A/6637A/6638A/6647A/6648A (660-D-8009-4, -6, -7, -8, -99-90, -99-92)

CAPACITORS			TRANSISTORS		
REF. DES.	DESCRIPTION	WILTRON PART NO.	REF. DES.	DESCRIPTION	WILTRON PART NO.
C1	Tantalum, 4.7 μF	250-39	CR2	Silicon, 1N4446	10-1N4446
C2	Tantalum, 4.7 μF	250-39	CR3	Silicon, SI2	10-SI2
C3	Tantalum, 4.7 μF	250-39	CR4	Zener, 24V, 1W, 1N4749A	10-1N4749A
C4	Disc Ceramic, .01 μF	230-11	CR5	Silicon, SI2	10-SI2
C5	Disc Ceramic, .001 μF	230-30	CR6	Silicon, 1N4446	10-1N4446
C6	Tantalum, 1 μF, 35V	250-19	CR7	Silicon, 1N4446	10-1N4446
C7	Tantalum, 1 μF, 35V	250-19	CR8	Silicon, 1N4446	10-1N4446
C8	Monolithic, 1.0 μF	230-41	CR9	Zener, 10V, 0.4W, 1N758A	10-1N758A
C9	Mica, 300 pF	220-300	CR10	Silicon, 1N4446	10-1N4446
C10	Monolithic, .1 μF	230-37	CR11	Silicon, 1N4446	10-1N4446
C11	Tantalum, 6.8 μF	250-41A			
C12	Mica, 5 pF	220-5			
C13	Monolithic, .1 μF	230-37			
C14	Disc Ceramic, .01 μF	230-11			
C16	Monolithic, .1 μF	230-37			
C17	Disc Ceramic, .01 μF	230-11			
C18	Disc Ceramic, .01 μF	230-11			
C19	Disc Ceramic, .01 μF	230-11			
C20	Mica, 820 pF	220-820			
DIODES			RESISTORS		
REF. DES.	DESCRIPTION	WILTRON PART NO.	REF. DES.	DESCRIPTION	WILTRON PART NO.
CR1	Silicon, 1N4446	10-1N4446	R1	CC, 1/4W, 5%, 3.3 MΩ	101-3.3M-5
			R2	Variable, 15-Turn, 50 kΩ	157-50k

R3	CC, 1/4W, 5%, 3.6 MΩ	101-3.6M-5
R4	MF, 1/4W, 1%, 61.9 kΩ	110-61.9k-1
R5	Variable, 15-Turn, 1 kΩ	157-1k
R7	Variable, 15-Turn, 1 kΩ	157-1k
R9	Variable, 15-Turn, 200 kΩ	157-200k
R10	MF, 1/4W, 1%, 205 kΩ	110-205k-1
R10 ⁵	MF, 1/4W, 1%, 6.65 kΩ	110-6.65k-1
R10 ⁶	MF, 1/4W, 1%, 10 kΩ	110-10k-1
R11 ¹	MF, 1/4W, 1%, 10.5 kΩ	110-10.5k-1
R11 ²	MF, 1/4W, 1%, 11 kΩ	110-11k-1
R11 ³	MF, 1/4W, 1%, 10 kΩ	110-10k-1
R11 ⁴	MF, 1/4W, 1%, 11 kΩ	110-11k-1
R12	MF, 1/4W, 1%, 20 kΩ	110-20k-1
R13	Variable, 1-Turn, 20 kΩ	156-20k
R14	MF, 1/4W, 1%, 2.74 kΩ	110-2.74k-1
R14 ⁵	MF, 1/4W, 1%, 2.67 kΩ	110-2.67k-1
R14 ⁶	MF, 1/4W, 1%, 4.22 kΩ	110-4.22k-1
R15	MF, 1/4W, 1%, 10 kΩ	110-10k-1
R16	MF, 1/4W, 1%, 4.99 kΩ	110-4.99k-1
R17	MF, 1/4W, 1%, 10 kΩ	110-10k-1
R18	MF, 1/4W, 1%, 23.7 kΩ	110-23.7k-1
R19	MF, 1/4W, 1%, 1 kΩ	110-1k-1
R20	MF, 1/4W, 1%, 121Ω	110-121-1
R21	MF, 1/4W, 1%, 1 kΩ	110-1k-1
R22	MF, 1/4W, 1%, 7.5 kΩ	110-7.5k-1
R23	MF, 1/4W, 1%, 511Ω	110-511-1
R24	MF, 1/4W, 1%, 5.11 kΩ	110-5.11k-1
R25	WW, 5W, 5Ω	131-3
R26	MF, 1/4W, 1%, 10 kΩ	110-10k-1
R27	MF, 1/4W, 1%, 750Ω	110-750-1
R28	MF, 1/4W, 1%, 5.49 kΩ	110-5.49k-1
R29	MF, 1/4W, 1%, 1.78 kΩ	110-1.78k-1
R30	MF, 1/4W, 1%, 2.15 kΩ	110-2.15k-1
R31	MF, 1/4W, 1%, 1 kΩ	110-1k-1
R32	MF, 1/4W, 1%, 1.21 kΩ	110-1.21k-1
R33	MF, 1/4W, 1%, 17.8 kΩ	110-17.8k-1
R34	Variable, 1-Turn, 200 kΩ	156-200k
R35	MF, 1/4W, 1%, 1 kΩ	110-1k-1
R38	MF, 1/4W, 1%, 18.7 kΩ	110-18.7k-1
R39	MF, 1/4W, 1%, 18.7 kΩ	110-18.7k-1
R42	Variable, 15-Turn, 50 kΩ	157-50k
R43	MF, 1/4W, 1%, 18.7 kΩ	110-18.7k-1
R44	MF, 1/4W, 1%, 18.7 kΩ	110-18.7k-1
R45	MF, 1/4W, 1%, 10 kΩ	110-10k-1
R46	MF, 1/4W, 1%, 9.53 kΩ	110-9.53k-1
R47	Variable, 15-Turn, 1 kΩ	157-1k
R48	MF, 1/4W, 1%, 11 kΩ	110-11k-1
R49	MF, 1/4W, 1%, 10 kΩ	110-10k-1
R50	MF, 1/4W, 1%, 511Ω	110-511-1
R51	MF, 1/4W, 1%, 4.99 kΩ	110-4.99k-1
R52	MF, 1/4W, 1%, 3.83 kΩ	110-3.83k-1
R53	MF, 1/4W, 1%, 1 kΩ	110-1k-1
R54	MF, 1/4W, 1%, 511Ω	110-511-1
R55	MF, 1/4W, 1%, 6.19Ω	110-6.19-1
R55 ⁵	MF, 1/4W, 1%, 6.49Ω	110-6.49-1
R55 ⁶	MF, 1/4W, 1%, 6.49Ω	110-6.49-1
R56	MF, 1/4W, 1%, 6.19Ω	110-6.19-1
R56 ⁵	MF, 1/4W, 1%, 6.49Ω	110-6.49-1
R57	MF, 1/4W, 1%, 6.19Ω	110-6.19-1
R57 ⁵	MF, 1/4W, 1%, 6.49Ω	110-6.49-1
R57 ⁶	MF, 1/4W, 1%, 6.49Ω	110-6.49-1
R58	MF, 1/4W, 1%, 6.19Ω	110-6.19-1
R58 ⁵	MF, 1/4W, 1%, 6.49Ω	110-6.49-1
R58 ⁶	MF, 1/4W, 1%, 6.49Ω	110-6.49-1

¹Used on 660-D-8009-4 assembly.

²Used on 660-D-8009-6 assembly.

³Used on 660-D-8009-7 assembly.

⁴Used on 660-D-8009-8 assembly.

⁵Used on 660-D-8009-99-90 assembly.

⁶Used on 660-D-8009-99-91 assembly.

R59	MF, 1/4W, 1%, 6.19Ω	110-6.19-1
R59 ⁵	MF, 1/4W, 1%, 6.49Ω	110-6.49-1
R59 ⁶	MF, 1/4W, 1%, 6.49Ω	110-6.49-1
R60	MF, 1/4W, 1%, 2.15 kΩ	110-2.15k-1
R61 ¹	MF, 1/4W, 1%, 33.2 kΩ	110-33.2k-1
R61 ²	MF, 1/4W, 1%, 33.2 kΩ	110-33.2k-1
R61 ³	MF, 1/4W, 1%, 38.3 kΩ	110-38.3k-1
R61 ⁴	MF, 1/4W, 1%, 38.3 kΩ	110-38.3k-1
R62 ¹	MF, 1/4W, 1%, 33.2 kΩ	110-33.2k-1
R62 ²	MF, 1/4W, 1%, 33.2 kΩ	110-33.2k-1
R62 ³	MF, 1/4W, 1%, 38.3 kΩ	110-38.3k-1
R62 ⁴	MF, 1/4W, 1%, 38.3 kΩ	110-38.3k-1
R62 ⁵	MF, 1/4W, 1%, 10.7 kΩ	110-10.7k-1
R62 ⁶	MF, 1/4W, 1%, 10.7 kΩ	110-10.7k-1
R63	MF, 1/4W, 1%, 10 kΩ	110-10k-1
R64	MF, 1/4W, 1%, 10 kΩ	110-10k-1
R65	MF, 1/4W, 1%, 750 kΩ	110-750k-1
R66	MF, 1/4W, 1%, 14.7 kΩ	110-14.7k-1
R67	MF, 1/4W, 1%, 866Ω	110-866-1
R67 ²	MF, 1/4W, 1%, 1.15 kΩ	110-1.15k-1
R67 ³	MF, 1/4W, 1%, 866Ω	110-866-1
R67 ⁴	MF, 1/4W, 1%, 1.15 kΩ	110-1.15k-1
R67 ⁵	MF, 1/4W, 1%, 5.11Ω	110-5.11-1
R67 ⁶	MF, 1/4W, 1%, 866Ω	110-866-1
R68	Variable, 15-Turn, 500Ω	157-500
R69	MF, 1/4W, 1%, 2 kΩ	110-2k-1
R70	MF, 1/4W, 1%, 10 kΩ	110-10k-1
R71	MF, 1/4W, 1%, 750 kΩ	110-750k-1
R72	MF, 1/4W, 1%, 14.7 kΩ	110-14.7k-1
R73	MF, 1/4W, 1%, 10 kΩ	110-10k-1
R74	MF, 1/4W, 1%, 10 kΩ	110-10k-1
R75	MF, 1/4W, 1%, 205 kΩ	110-205k-1
R76	MF, 1/4W, 1%, 511Ω	110-511-1
R77	Variable, 1-Turn, 20Ω	156-20
R78	MF, 1/4W, 1%, 2 kΩ	110-2k-1
R79	MF, 1/4W, 1%, 15 kΩ	110-15k-1
R80	MF, 1/4W, 1%, 511Ω	110-511-1
R81	MF, 1/4W, 1%, 511Ω	110-511-1
R82	MF, 1/4W, 1%, 100 kΩ	110-100k-1
R83	MF, 1/4W, 1%, 100 kΩ	110-100k-1
R84	MF, 1/4W, 1%, 5.11 kΩ	110-5.11k-1
R85	MF, 1/4W, 1%, 5.11 kΩ	110-5.11k-1
R86	MF, 1/4W, 1%, 5.11Ω	110-5.11-1

INTEGRATED CIRCUITS

REF. DES.	DESCRIPTION	WILTRON PART NO.
U1	Quad Analog Switch, LF13201	54-20
U2	NAND Gate, 74LS10	54-42
U3	Op Amp, OP05	54-87
U4	Quad Op Amp, TL072	54-53
U5	2k x 8 EPROM	Not Field-Replaceable
U7	Quad Op Amp, TL074	54-132
U8	Quad Ex. OR Gate, 74LS86	54-125
U9	Dual Volt. Comp., LM393	54-158

MISCELLANEOUS

REF. DES.	DESCRIPTION	WILTRON PART NO.
---	Ejector, PC Board	553-96
TP1 thru TP4	Pin, Test Point	706-44
K1	Relay, 2 Form C	690-28
---	Socket, I.C., 24-Pin	553-67

Table 6-13. A6/A7 YIG Driver, 8-12.4 GHz, 6621A-40/6629A-40/6637A-40
(660-D-8009-14, -17, -99-91, -99-93)

<u>CAPACITORS</u>					
REF. DES.	DESCRIPTION	WILTRON PART NO.			
C1	Tantalum, 4.7 μ F	250-39A	R3	CC, 1/4W, 5%, 3.6 M Ω	101-3.6M-5
C2	Tantalum, 4.7 μ F	250-39A	R4	MF, 1/4W, 1%, 61.9 k Ω	110-61.9k-1
C3	Tantalum, 4.7 μ F	250-39A	R5	Variable, 15-Turn, 1 k Ω	157-1k
C4	Disc Ceramic, .01 μ F	230-11	R6	MF, 1/4W, 1%, 11 k Ω	110-11k-1
C5	Disc Ceramic, .001 μ F	230-30	R7	Variable, 15-Turn, 1 k Ω	157-1k
C6	Monolithic, .1 μ F	230-37	R8	MF, 1/4W, 1%, 11 k Ω	110-11k-1
C7	Monolithic, .1 μ F	230-37	R9	Variable, 15-Turn, 200 k Ω	157-200k
C8	Monolithic, 1.0 μ F	230-41	R10	MF, 1/4W, 1%, 205 k Ω	110-205k-1
C9	Not Used		R11 ¹	MF, 1/4W, 1%, 10.5 k Ω	110-10.5k-1
C10	Monolithic, .1 μ F	230-37	R11 ²	MF, 1/4W, 1%, 10 k Ω	110-10k-1
C11	Tantalum, 6.8 μ F	250-41	R11 ³	MF, 1/4W, 1%, 6.65 k Ω	110-6.65k-1
C12	Mica, 5 pF	220-5	R11 ⁴	MF, 1/4W, 1%, 10 k Ω	110-10k-1
C13	Monolithic, .1 μ F	230-37	R12	MF, 1/4W, 1%, 20 k Ω	110-20k-1
C14	Disc Ceramic, .01 μ F	230-11	R13	Variable, 1-Turn, 20 k Ω	156-20k
C15	Not Used		R14	MF, 1/4W, 1%, 2.74 k Ω	110-2.74k-1
C16	Monolithic, .1 μ F	230-37	R14 ³	MF, 1/4W, 1%, 2.67 k Ω	110-2.67k-1
C17	Disc Ceramic, .01 μ F	230-11	R14 ⁴	MF, 1/4W, 1%, 4.22 k Ω	110-4.22k-1
C18	Disc Ceramic, .01 μ F	230-11	R15	MF, 1/4W, 1%, 10 k Ω	110-10k-1
C19	Disc Ceramic, .01 μ F	230-11	R16	MF, 1/4W, 1%, 4.99 k Ω	110-4.99k-1
C20	Mica, 300 pF	220-300	R17	MF, 1/4W, 1%, 10 k Ω	110-10k-1
			R18	MF, 1/4W, 1%, 23.7 k Ω	110-23.7k-1
			R19	MF, 1/4W, 1%, 1 k Ω	110-1k-1
			R20	MF, 1/4W, 1%, 121 Ω	110-121-1
			R21	MF, 1/4W, 1%, 1 k Ω	110-1k-1
			R22	MF, 1/4W, 1%, 7.5 k Ω	110-7.5k-1
			R23	MF, 1/4W, 1%, 511 Ω	110-511-1
			R24	MF, 1/4W, 1%, 5.11 k Ω	110-5.11k-1
			R25	WW, 5W, 5 Ω	131-3
			R26	MF, 1/4W, 1%, 10 k Ω	110-10k-1
			R27	MF, 1/4W, 1%, 750 Ω	110-750-1
			R28	MF, 1/4W, 1%, 5.49 k Ω	110-5.49k-1
			R29	MF, 1/4W, 1%, 1.78 k Ω	110-1.78k-1
			R30	MF, 1/4W, 1%, 2.15 k Ω	110-2.15k-1
			R31	MF, 1/4W, 1%, 1k	110-1k-1
			R32	MF, 1/4W, 1%, 1.21 k Ω	110-1.21k-1
			R33	MF, 1/4W, 1%, 17.8 k Ω	110-17.8k-1
			R34	Variable, 1-Turn, 200 k Ω	156-200k
			R35	MF, 1/4W, 1%, 1 k Ω	110-1k-1
			R36	MF, 1/4W, 1%, 10 k Ω	110-10k-1
			R37	MF, 1/4W, 1%, 10 k Ω	110-10k-1
			R38	MF, 1/4W, 1%, 18.7 k Ω	110-18.7k-1
			R39	MF, 1/4W, 1%, 18.7 k Ω	110-18.7k-1
			R42	Variable, 15-Turn, 50 k Ω	157-50k
			R43	MF, 1/4W, 1%, 18.7 k Ω	110-18.7k-1
			R44	MF, 1/4W, 1%, 18.7 k Ω	110-18.7k-1
			R45	MF, 1/4W, 1%, 10 k Ω	110-10k-1
			R46	MF, 1/4W, 1%, 9.53 k Ω	110-9.53k-1
			R47	Variable, 15-Turn, 20 k Ω	157-20k
			R48	MF, 1/4W, 1%, 11 k Ω	110-11k-1
			R49	MF, 1/4W, 1%, 10 k Ω	110-10k-1
			R50	MF, 1/4W, 1%, 511 Ω	110-511-1
			R51	MF, 1/4W, 1%, 4.99 k Ω	110-4.99k-1
			R52	MF, 1/4W, 1%, 3.83 k Ω	110-3.83k-1
			R53	MF, 1/4W, 1%, 1 k Ω	110-1k-1
			R54	MF, 1/4W, 1%, 511 Ω	110-511-1
			R55	MF, 1/4W, 1%, 8.66 Ω	110-8.66-1
			R56	MF, 1/4W, 1%, 8.66 Ω	110-8.66-1
			R57	MF, 1/4W, 1%, 8.66 Ω	110-8.66-1
			R58	MF, 1/4W, 1%, 8.66 Ω	110-8.66-1
			R59	MF, 1/4W, 1%, 8.66 Ω	110-8.66-1
			R60	MF, 1/4W, 1%, 2.15 k Ω	110-2.15k-1
			R61 ¹	MF, 1/4W, 1%, 33.2 k Ω	110-33.2k-1
			R61 ²	MF, 1/4W, 1%, 38.3 k Ω	110-38.3k-1
			R61 ³	MF, 1/4W, 1%, 33.2 k Ω	110-33.2k-1
			R61 ⁴	MF, 1/4W, 1%, 33.2 k Ω	110-33.2k-1
			R62 ¹	MF, 1/4W, 1%, 33.2 k Ω	110-33.2k-1

<u>DIODES</u>		
REF. DES.	DESCRIPTION	WILTRON PART NO.
CR1	Silicon, 1N4446	10-1N4446
CR2	Not Used	
CR3	Silicon, SI2	10-SI2
CR4	Zener, 24V, 1W, 1N4749A	10-1N4749A
CR5	Silicon, SI2	10-SI2
CR6	Silicon, 1N4446	10-1N4446
CR7	Silicon, 1N4446	10-1N4446
CR8	Silicon, 1N4446	10-1N4446
CR9	Zener, 10V, 0.4W, 1N758A	10-1N758A
CR10	Silicon, 1N4446	10-1N4446
CR11	Silicon, 1N4446	10-1N4446

<u>TRANSISTORS</u>		
REF. DES.	DESCRIPTION	WILTRON PART NO.
Q1	PNP, MPSA92	20-MPSA92
Q2	PNP, MPSA92	20-MPSA92
Q3	NPN, 2N3694	20-2N3694
Q4	NPN, 2N2222A	20-2N2222A
Q5	NPN, 2N2222A	20-2N2222A
Q6	PNP, 2N2907A	20-2N2907A
Q7	NPN, 2N2222A	20-2N2222A
Q8	NPN, 2N2222A	20-2N2222A

<u>RESISTORS</u>		
REF. DES.	DESCRIPTION	WILTRON PART NO.
R1	CC, 1/4W, 5%, 3.3 M Ω	101-3.3M-5
R2	Variable, 15-Turn, 50 k Ω	157-50k

¹Used on 660-D-8009-14 assembly.
²Used on 660-D-8009-17 assembly.
³Used on 660-D-8009-99-91 assembly.
⁴Used on 660-D-8009-99-93 assembly.

R62 ²	MF, 1/4W, 1%, 38.3 kΩ	110-38.3k-1
R62 ³	MF, 1/4W, 1%, 33.2 kΩ	110-33.2k-1
R62 ¹	MF, 1/4W, 1%, 33.2 kΩ	110-33.2k-1
R63	MF, 1/4W, 1%, 10 kΩ	110-10k-1
R64	MF, 1/4W, 1%, 10 kΩ	110-10k-1
R66	MF, 1/4W, 1%, 14.7 kΩ	110-14.7k-1
R67	MF, 1/4W, 1%, 866Ω	110-866-1
R67 ²	MF, 1/4W, 1%, 5.11Ω	110-5.11-1
R68	Variable, 15-Turn, 500Ω	157-500
R69	MF, 1/4W, 1%, 2 kΩ	110-2k-1
R70	MF, 1/4W, 1%, 10 kΩ	110-10k-1
R72	MF, 1/4W, 1%, 14.7 kΩ	110-14.7k-1
R73	MF, 1/4W, 1%, 10 kΩ	110-10k-1
R74	MF, 1/4W, 1%, 10 kΩ	110-10k-1
R75	MF, 1/4W, 1%, 205 kΩ	110-205k-1
R76	MF, 1/4W, 1%, 511Ω	110-511-1
R77	Variable, 1-Turn, 20Ω	156-20
R78	MF, 1/4W, 1%, 2 kΩ	110-2k-1
R79	MF, 1/4W, 1%, 15 kΩ	110-15k-1
R80	MF, 1/4W, 1%, 511Ω	110-511-1
R81	MF, 1/4W, 1%, 511Ω	110-511-1
R82	MF, 1/4W, 1%, 100 kΩ	110-100k-1
R83	MF, 1/4W, 1%, 100 kΩ	110-100k-1
R84	MF, 1/4W, 1%, 5.11 kΩ	110-5.11k-1
R85	MF, 1/4W, 1%, 5.11 kΩ	110-5.11k-1
R86	MF, 1/4W, 1%, 5.11Ω	110-5.11-1

INTEGRATED CIRCUITS

REF. DES.	DESCRIPTION	WILTRON PART NO.
U1	Quad Analog Switch, LF13201	54-20
U2	NAND Gate, 74LS10	54-42
U3	Op Amp, OP05	54-87
U4	Quad Op Amp, TL072	54-53
U5	2k x 8 EPROM	Not Field-Replaceable
U7	Quad Op Amp, TL074	54-132
U8	Quad Ex. OR Gate, 74LS86	54-125
U9	Dual Volt. Comp., LM393	54-158

MISCELLANEOUS

REF. DES.	DESCRIPTION	WILTRON PART NO.
---	Ejector, PC Board	553-96
TP1 thru		
TP4	Pin, Test Point	706-44
K1	Relay, 2 Form C	690-28
---	Socket, I.C., 24-Pin	553-67

Table 6-14. A6/A7/A8 YIG Driver, 12.4-18.6 GHz, 6629A-40/6637A-40 (660-D-8009-15, -16, -99-94)

CAPACITORS			TRANSISTORS		
REF. DES.	DESCRIPTION	WILTRON PART NO.	REF. DES.	DESCRIPTION	WILTRON PART NO.
C1	Tantalum, 4.7 μF	250-39A	Q1	PNP, MPSA92	20-MPSA92
C2	Tantalum, 4.7 μF	250-39A	Q2	PNP, MPSA92	20-MPSA92
C3	Tantalum, 4.7 μF	250-39A	Q3	NPN, 2N3694	20-2N3694
C4	Disc Ceramic, .01 μF	230-11	Q4	NPN, 2N2222A	20-2N2222A
C5	Disc Ceramic, .001 μF	230-30	Q5	NPN, 2N2222A	20-2N2222A
C6	Monolithic, .1 μF	230-37	Q6	PNP, 2N2907A	20-2N2907A
C7	Monolithic, .1 μF	230-37	Q7	NPN, 2N2222A	20-2N2222A
C8	Monolithic, 1.0 μF	230-41	Q8	NPN, 2N2222A	20-2N2222A
C9	Not Used				
C10	Monolithic, .1 μF	230-37			
C11	Tantalum, 6.8 μF	250-41			
C12	Mica, 5 pF	220-5			
C13	Monolithic, .1 μF	230-37			
C14	Disc Ceramic, .01 μF	230-11			
C15	Not Used				
C16	Monolithic, .1 μF	230-37			
C17	Disc Ceramic, .01 μF	230-11			
C18	Disc Ceramic, .01 μF	230-11			
C19	Disc Ceramic, .01 μF	230-11			
C20	Mica, 300 pF	220-300			
DIODES			RESISTORS		
REF. DES.	DESCRIPTION	WILTRON PART NO.	REF. DES.	DESCRIPTION	WILTRON PART NO.
CR1	Silicon, 1N4446	10-1N4446	R1	CC, 1/4W, 5%, 3.3 MΩ	101-3.3M-5
CR2	Not Used		R2	Variable, 15-Turn, 50 kΩ	157-50k
CR3	Silicon, SI2	10-SI2	R3	CC, 1/4W, 5%, 3.6 MΩ	101-3.6M-5
CR4	Zener, 24V, 1W, 1N4749A	10-1N4749A	R4	MF, 1/4W, 1%, 61.9 kΩ	110-61.9k-1
			R5	Variable, 15-Turn, 1 kΩ	157-1k
			R6	MF, 1/4W, 1%, 11 kΩ	110-11k-1
			R7	Variable, 15-Turn, 1 kΩ	157-1k
			R8	MF, 1/4W, 1%, 11 kΩ	110-11k-1

¹Used on 660-D-8009-14 assembly.

²Used on 660-D-8009-17 assembly.

R9	Variable, 15-Turn, 200 kΩ	157-200k
R10	MF, 1/4W, 1%, 205 kΩ	110-205k-1
R11 ¹	MF, 1/4W, 1%, 4.64 kΩ	110-4.64k-1
R11 ²	MF, 1/4W, 1%, 4.22 kΩ	110-4.22k-1
R11 ³	MF, 1/4W, 1%, 7.68 kΩ	110-7.68k-1
R12	MF, 1/4W, 1%, 20 kΩ	110-20k-1
R13	Variable, 1-Turn, 20 kΩ	156-20k
R14 ¹	MF, 1/4W, 1%, 1.91 kΩ	110-1.91k-1
R14 ²	MF, 1/4W, 1%, 2.74 kΩ	110-2.74k-1
R14 ³	MF, 1/4W, 1%, 3.16 kΩ	110-3.16k-1
R15	MF, 1/4W, 1%, 10 kΩ	110-10k-1
R16	MF, 1/4W, 1%, 10 kΩ	110-10k-1
R17	MF, 1/4W, 1%, 10 kΩ	110-10k-1
R18	MF, 1/4W, 1%, 23.7 kΩ	110-23.7k-1
R19	MF, 1/4W, 1%, 1 kΩ	110-1k-1
R20	MF, 1/4W, 1%, 121Ω	110-121-1
R21	MF, 1/4W, 1%, 1 kΩ	110-1k-1
R22	MF, 1/4W, 1%, 7.5 kΩ	110-7.5k-1
R23	MF, 1/4W, 1%, 511Ω	110-511-1
R24	MF, 1/4W, 1%, 5.11 kΩ	110-5.11k-1
R25	WW, 5W, 2Ω	131-1
R26	MF, 1/4W, 1%, 10 kΩ	110-10k-1
R27	MF, 1/4W, 1%, 750Ω	110-750-1
R28	MF, 1/4W, 1%, 5.49 kΩ	110-5.49k-1
R29	MF, 1/4W, 1%, 1.78 kΩ	110-1.78k-1
R30	MF, 1/4W, 1%, 2.15 kΩ	110-2.15k-1
R31	MF, 1/4W, 1%, 1 kΩ	110-1k-1
R32	MF, 1/4W, 1%, 1.21 kΩ	110-1.21k-1
R33	MF, 1/4W, 1%, 17.8 kΩ	110-17.8k-1
R34	Variable, 1-Turn, 200 kΩ	156-200k
R35	MF, 1/4W, 1%, 1 kΩ	110-1k-1
R36	MF, 1/4W, 1%, 10 kΩ	110-10k-1
R37	MF, 1/4W, 1%, 10 kΩ	110-10k-1
R38	MF, 1/4W, 1%, 18.7 kΩ	110-18.7k-1
R39	MF, 1/4W, 1%, 18.7 kΩ	110-18.7k-1
R40 ³	MF, 1/4W, 1%, 61.9 kΩ	110-61.9k-1
R41 ³	MF, 1/4W, 1%, 61.9 kΩ	110-61.9k-1
R42	Variable, 15-Turn, 50 kΩ	157-50k
R43	MF, 1/4W, 1%, 18.7 kΩ	110-18.7k-1
R44	MF, 1/4W, 1%, 18.7 kΩ	110-18.7k-1
R45	MF, 1/4W, 1%, 10 kΩ	110-10k-1
R46 ¹	MF, 1/4W, 1%, 9.53 kΩ	110-9.53k-1
R46 ²	MF, 1/4W, 1%, 9.53 kΩ	110-9.53k-1
R46 ³	MF, 1/4W, 1%, 8.45 kΩ	110-8.45k-1
R47	Variable, 15-Turn, 20 kΩ	157-20k
R48	MF, 1/4W, 1%, 11 kΩ	110-11k-1
R49	MF, 1/4W, 1%, 10 kΩ	110-10k-1
R50	MF, 1/4W, 1%, 511Ω	110-511-1
R51	MF, 1/4W, 1%, 4.99 kΩ	110-4.99k-1
R52	MF, 1/4W, 1%, 3.83 kΩ	110-3.83k-1
R53	MF, 1/4W, 1%, 1 kΩ	110-1k-1
R54	MF, 1/4W, 1%, 511Ω	110-511-1
R55	MF, 1/4W, 1%, 8.66Ω	110-8.66-1
R56	MF, 1/4W, 1%, 8.66Ω	110-8.66-1
R57	MF, 1/4W, 1%, 8.66Ω	110-8.66-1
R58	MF, 1/4W, 1%, 8.66Ω	110-8.66-1

¹ Used on 660-D-8009-15 assembly.

² Used on 660-D-8009-16 assembly

³ Used on 660-D-8009-99-94 assembly.

R59	MF, 1/4W, 1%, 8.66Ω	110-8.66-1
R60	MF, 1/4W, 1%, 2.15 kΩ	110-2.15k-1
R61 ¹	MF, 1/4W, 1%, 100 kΩ	110-100k-1
R61 ²	MF, 1/4W, 1%, 100 kΩ	110-100k-1
R61 ³	MF, 1/4W, 1%, 33.2 kΩ	110-33.2k-1
R62 ³	MF, 1/4W, 1%, 33.2 kΩ	110-33.2k-1
R63	MF, 1/4W, 1%, 10 kΩ	110-10k-1
R64	MF, 1/4W, 1%, 10 kΩ	110-10k-1
R65	MF, 1/4W, 1%, 750 kΩ	110-750k-1
R66	MF, 1/4W, 1%, 14.7 kΩ	110-14.7k-1
R67 ¹	MF, 1/4W, 1%, 866Ω	110-866-1
R67 ²	MF, 1/4W, 1%, 866Ω	110-866-1
R67 ³	MF, 1/4W, 1%, 5.11Ω	110-5.11-1
R68	Variable, 15-Turn, 500Ω	157-500
R69	MF, 1/4W, 1%, 2 kΩ	110-2k-1
R70	MF, 1/4W, 1%, 10 kΩ	110-10k-1
R71	MF, 1/4W, 1%, 750 kΩ	110-750k-1
R72	MF, 1/4W, 1%, 14.7 kΩ	110-14.7k-1
R73	MF, 1/4W, 1%, 10 kΩ	110-10k-1
R74	MF, 1/4W, 1%, 10 kΩ	110-10k-1
R75	MF, 1/4W, 1%, 205 kΩ	110-205k-1
R76	MF, 1/4W, 1%, 511Ω	110-511-1
R77	Variable, 1-Turn, 20Ω	156-20
R78	MF, 1/4W, 1%, 2 kΩ	110-2k-1
R79	MF, 1/4W, 1%, 15 kΩ	110-15k-1
R80	MF, 1/4W, 1%, 511Ω	110-511-1
R81	MF, 1/4W, 1%, 511Ω	110-511-1
R82	MF, 1/4W, 1%, 100 kΩ	110-100k-1
R83	MF, 1/4W, 1%, 100 kΩ	110-100k-1
R84	MF, 1/4W, 1%, 5.11 kΩ	110-5.11k-1
R85	MF, 1/4W, 1%, 5.11 kΩ	110-5.11k-1
R86	MF, 1/4W, 1%, 5.11Ω	110-5.11-1

INTEGRATED CIRCUITS

REF. DES.	DESCRIPTION	WILTRON PART NO.
U1	Quad Analog Switch, LF13201	54-20
U2	NAND Gate, 74LS10	54-42
U3	Op Amp, OP05	54-87
U4	Quad Op Amp, TL072	54-53
U5	2k x 8 EPROM	Not Field-Replaceable
U7	Quad Op Amp, TL074	54-132
U8	Quad Ex. OR Gate, 74LS86	54-125
U9	Dual Volt. Comp., LM393	54-158

MISCELLANEOUS

REF. DES.	DESCRIPTION	WILTRON PART NO.
---	Ejector, PC Board	553-96
TP1 thru TP4	Pin, Test Point	706-44
K1	Relay, 2 Form C	690-28
---	Socket, I.C., 24-Pin	553-67

Table 6-15. A7/A8 YIG Driver, 12.4-18.6 (20) GHz, 6629A/6637A/6638A/6647A/6648A
(660-D-8008-4, -7, -99-90)

<u>CAPACITORS</u>					
REF. DES.	DESCRIPTION	WILTRON PART NO.			
C1	Tantalum, 4.7 μ F	250-39	R2	Variable, 15-Turn, 50 k Ω	157-50k
C2	Tantalum, 4.7 μ F	250-39	R3	CC, 1/4W, 5%, 3.6 M Ω	101-3.6M-5
C3	Tantalum, 4.7 μ F	250-39	R4	MF, 1/4W, 1%, 61.9 k Ω	110-61.9k-1
C4	Disc Ceramic, .01 μ F	230-11	R5	Variable, 15-Turn, 1 k Ω	157-1k
C5	Disc Ceramic, .001 μ F	230-30	R6	MF, 1/4W, 1%, 11 k Ω	110-11k-1
C6	Tantalum, 1 μ F, 35V	250-19	R7	Variable, 15-Turn, 1 k Ω	157-1k
C7	Tantalum, 1 μ F, 35V	250-19	R8	MF, 1/4W, 1%, 11 k Ω	110-11k-1
C8	Monolithic, 1.0 μ F	230-41	R9	Variable, 15-Turn, 200 k Ω	157-200k
C9	Mica, 300 pF	220-300	R10 ¹	MF, 1/4W, 1%, 210 k Ω	110-210k-1
C10	Monolithic, .1 μ F	230-37	R10 ²	MF, 1/4W, 1%, 205 k Ω	110-205k-1
C11	Tantalum, 6.8 μ F	250-41	R11 ¹	MF, 1/4W, 1%, 5.11 k Ω	110-5.11k-1
C12	Mica, 5 pF	220-5	R11 ²	MF, 1/4W, 1%, 7.68 k Ω	110-7.68k-1
C13	Monolithic, .1 μ F	230-37	R12	MF, 1/4W, 1%, 20 k Ω	110-20k-1
C14	Disc Ceramic, .01 μ F	230-11	R13	Variable, 1-Turn, 20 k Ω	156-20k
C15	Mica, 820 pF	220-820	R14 ¹	MF, 1/4W, 1%, 1.87 k Ω	110-1.87k-1
C16	Monolithic, .1 μ F	230-37	R14 ²	MF, 1/4W, 1%, 3.16 k Ω	110-3.16k-1
C17	Disc Ceramic, .01 μ F	230-11	R15	MF, 1/4W, 1%, 10 k Ω	110-10k-1
C18	Disc Ceramic, .01 μ F	230-11	R16	MF, 1/4W, 1%, 4.99 k Ω	110-4.99k-1
C19	Disc Ceramic, .01 μ F	230-11	R17	MF, 1/4W, 1%, 10 k Ω	110-10k-1
			R18	MF, 1/4W, 1%, 23.7 k Ω	110-23.7k-1
			R19	MF, 1/4W, 1%, 1 k Ω	110-1k-1
			R20	MF, 1/4W, 1%, 121 Ω	110-121-1
			R21	MF, 1/4W, 1%, 1 k Ω	110-1k-1
			R22	MF, 1/4W, 1%, 7.5 k Ω	110-7.5k-1
			R23	MF, 1/4W, 1%, 511 Ω	110-511-1
			R24	MF, 1/4W, 1%, 5.11 k Ω	110-5.11k-1
			R25	WW, 5W, 3 Ω	131-2
			R26	MF, 1/4W, 1%, 10 k Ω	110-10k-1
			R27	MF, 1/4W, 1%, 750 Ω	110-750-1
			R28	MF, 1/4W, 1%, 5.49 k Ω	110-5.49k-1
			R29	MF, 1/4W, 1%, 1.78 k Ω	110-1.78k-1
			R30	MF, 1/4W, 1%, 2.15 k Ω	110-2.15k-1
			R31	MF, 1/4W, 1%, 1k	110-1k-1
			R32	MF, 1/4W, 1%, 1.21 k Ω	110-1.21k-1
			R33	MF, 1/4W, 1%, 17.8 k Ω	110-17.8k-1
			R34	Variable, 1-Turn, 200 k Ω	156-200k
			R35	MF, 1/4W, 1%, 1 k Ω	110-1k-1
			R38	MF, 1/4W, 1%, 18.7 k Ω	110-18.7k-1
			R39	MF, 1/4W, 1%, 18.7 k Ω	110-18.7k-1
			R40	MF, 1/4W, 1%, 10 k Ω	110-10k-1
			R41 ¹	MF, 1/4W, 1%, 110 k Ω	110-110k-1
			R41 ²	MF, 1/4W, 1%, 61.9 k Ω	110-61.9k-1
			R42	Variable, 15-Turn, 50 k Ω	157-50k
			R43	MF, 1/4W, 1%, 18.7 k Ω	110-18.7k-1
			R44	MF, 1/4W, 1%, 18.7 k Ω	110-18.7k-1
			R45	MF, 1/4W, 1%, 10 k Ω	110-10k-1
			R46	MF, 1/4W, 1%, 8.45 k Ω	110-8.45k-1
			R47	Variable, 15-Turn, 10 k Ω	157-10k
			R48	MF, 1/4W, 1%, 11 k Ω	110-11k-1
			R49	MF, 1/4W, 1%, 10 k Ω	110-10k-1
			R50	MF, 1/4W, 1%, 511 Ω	110-511-1
			R51	MF, 1/4W, 1%, 4.99 k Ω	110-4.99k-1
			R52	MF, 1/4W, 1%, 3.83 k Ω	110-3.83k-1
			R53	MF, 1/4W, 1%, 1 k Ω	110-1k-1
			R54	MF, 1/4W, 1%, 511 Ω	110-511-1
			R55	MF, 1/4W, 1%, 8.06 Ω	110-8.66-1
			R56	MF, 1/4W, 1%, 8.06 Ω	110-8.66-1
			R57	MF, 1/4W, 1%, 8.06 Ω	110-8.66-1
			R58	MF, 1/4W, 1%, 8.06 Ω	110-8.66-1
			R59	CC, 1/2W, .5 Ω	102-.5-5
			R60	MF, 1/4W, 1%, 2.15 k Ω	110-2.15k-1
			R61 ¹	MF, 1/4W, 1%, 110 k Ω	110-110k-1
			R61 ²	MF, 1/4W, 1%, 33.2 k Ω	110-33.2k-1
			R62 ²	MF, 1/4W, 1%, 33.2 k Ω	110-33.2k-1
			R63	MF, 1/4W, 1%, 10 k Ω	110-10k-1
			R64	MF, 1/4W, 1%, 10 k Ω	110-10k-1

<u>DIODES</u>		
REF. DES.	DESCRIPTION	WILTRON PART NO.
CR1	Silicon, 1N4446	10-1N4446
CR2	Silicon, 1N4446	10-1N4446
CR3	Silicon, SI2	10-SI2
CR4	Zener, 24V, 1W, 1N4749A	10-1N4749A
CR5	Silicon, SI2	10-SI2
CR6	Silicon, 1N4446	10-1N4446
CR7	Silicon, 1N4446	10-1N4446
CR8	Silicon, 1N4446	10-1N4446
CR9	Zener, 10V, 0.4W, 1N758A	10-1N758A
CR10	Silicon, 1N4446	10-1N4446
CR11	Silicon, 1N4446	10-1N4446

<u>TRANSISTORS</u>		
REF. DES.	DESCRIPTION	WILTRON PART NO.
Q1	PNP, MPSA92	20-MPSA92
Q2	PNP, MPSA92	20-MPSA92
Q3	NPN, 2N3694	20-2N3694
Q4	NPN, 2N2222A	20-2N2222A
Q5	PNP, 2N2907A	20-2N2907A
Q6	NPN, 2N2222A	20-2N2222A
Q7	PNP, 2N2907A	20-2N2907A

<u>RESISTORS</u>		
REF. DES.	DESCRIPTION	WILTRON PART NO.
R1	CC, 1/4W, 5%, 3.3 M Ω	101-3.3M-5

¹Used on 660-D-8008-4 and -7 assemblies.

²Used on 660-D-8008-99-90 assembly.

R18	MF, 1/4W, 1%, 23.7 k Ω	110-23.7k-1	R66	MF, 1/4W, 1%, 14.7 k Ω	110-14.7k-1
R19	MF, 1/4W, 1%, 1 k Ω	110-1k-1	R67	MF, 1/4W, 1%, 5.11 Ω	110-5.11-1
R20	MF, 1/4W, 1%, 121 Ω	110-121-1	R68	Variable, 1-Turn, 500 Ω	157-500
R21	MF, 1/4W, 1%, 1 k Ω	110-1k-1	R69	MF, 1/4W, 1%, 2 k Ω	110-2k-1
R22	MF, 1/4W, 1%, 7.5 k Ω	110-7.5k-1	R70	MF, 1/4W, 1%, 10 k Ω	110-10k-1
R23	MF, 1/4W, 1%, 511 Ω	110-511-1	R71	MF, 1/4W, 1%, 750 k Ω	110-750k-1
R24	MF, 1/4W, 1%, 5.11 k Ω	110-5.11k-1	R72	MF, 1/4W, 1%, 14.7 k Ω	110-14.7k-1
R25	WW, 5W, 5 Ω	131-3	R73	MF, 1/4W, 1%, 10 k Ω	110-10k-1
R26	MF, 1/4W, 1%, 15.4 k Ω	110-15k-1	R74	MF, 1/4W, 1%, 10 k Ω	110-10k-1
R27	MF, 1/4W, 1%, 649 Ω	110-649-1	R75	MF, 1/4W, 1%, 750 k Ω	110-750k-1
R28	MF, 1/4W, 1%, 6.19 k Ω	110-6.19k-1	R76	MF, 1/4W, 1%, 511 Ω	110-511-1
R29	MF, 1/4W, 1%, 1.37 k Ω	110-1.37k-1	R77	Variable, 1-Turn, 20 Ω	156-20
R30	MF, 1/4W, 1%, 3.83 k Ω	110-3.83k-1	R78	MF, 1/4W, 1%, 2 k Ω	110-2k-1
R31	MF, 1/4W, 1%, 1 k Ω	110-1k-1	R79	MF, 1/4W, 1%, 14.7 k Ω	110-14.7k-1
R32	MF, 1/4W, 1%, 1.21 k Ω	110-1.21k-1	R80	MF, 1/4W, 1%, 23.7 k Ω	110-23.7k-1
R33	MF, 1/4W, 1%, 17.8 k Ω	110-17.8k-1	R81	MF, 1/4W, 1%, 23.7 k Ω	110-23.7k-1
R34	Variable, 1-Turn, 500 k Ω	156-500k	R82	MF, 1/4W, 1%, 20 k Ω	110-20k-1
R35	MF, 1/4W, 1%, 49.9 k Ω	110-49.9k-1	R83	MF, 1/4W, 1%, 20 k Ω	110-20k-1
R36	MF, 1/4W, 1%, 5.11 k Ω	110-5.11k-1	R84	MF, 1/4W, 1%, 5.11 k Ω	110-5.11k-1
R37	MF, 1/4W, 1%, 5.11 k Ω	110-5.11k-1	R85	MF, 1/4W, 1%, 5.11 k Ω	110-5.11k-1
R38	MF, 1/4W, 1%, 18.7 k Ω	110-18.7k-1	R86	MF, 1/4W, 1%, 5.11 Ω	110-5.11-1
R39	MF, 1/4W, 1%, 18.7 k Ω	110-18.7k-1			
R40	MF, 1/4W, 1%, 10 k Ω	110-10k-1			
R41	MF, 1/4W, 1%, 100 k Ω	110-100k-1			
R42	Variable, 1-Turn, 50 k Ω	157-50k			
R43	MF, 1/4W, 1%, 18.7 k Ω	110-18.7k-1			
R44	MF, 1/4W, 1%, 18.7 k Ω	110-18.7k-1			
R45	MF, 1/4W, 1%, 10 k Ω	110-10k-1			
R46	MF, 1/4W, 1%, 8.45 k Ω	110-8.45k-1			
R47	Variable, 1-Turn, 10 k Ω	157-10k			
R48	MF, 1/4W, 1%, 11 k Ω	110-11k-1			
R49	MF, 1/4W, 1%, 10 k Ω	110-10k-1			
R50	MF, 1/4W, 1%, 511 Ω	110-511-1			
R51	MF, 1/4W, 1%, 4.99 k Ω	110-4.99k-1			
R52	MF, 1/4W, 1%, 3.83 k Ω	110-3.83k-1			
R53	MF, 1/4W, 1%, 1 k Ω	110-1k-1			
R54	MF, 1/4W, 1%, 511 Ω	110-511-1			
R55	MF, 1/4W, 1%, 5.11 Ω	110-5.11-1			
R56	MF, 1/4W, 1%, 5.11 Ω	110-5.11-1			
R57	MF, 1/4W, 1%, 5.11 Ω	110-5.11-1			
R58	MF, 1/4W, 1%, 5.11 Ω	110-5.11-1			
R59	CC, 1/2W, 5%, .5 Ω	102-.5-5			
R60	MF, 1/4W, 1%, 2.15 k Ω	110-2.15k-1			
R61	MF, 1/4W, 1%, 511 Ω	110-511-1			
R62	MF, 1/4W, 1%, 12.1 k Ω	110-12.1k-1			
R63	MF, 1/4W, 1%, 10 k Ω	110-10k-1			
R64	MF, 1/4W, 1%, 10 k Ω	110-10k-1			
R65	MF, 1/4W, 1%, 750 k Ω	110-750k-1			

INTEGRATED CIRCUITS

REF. DES.	DESCRIPTION	WILTRON PART NO.
U1	Quad Analog Switch, LF13201	54-20
U2	NAND Gate, 74LS10	54-42
U3	Op Amp, OP05	54-87
U4	Quad Op Amp, TL072	54-53
U5	256 x 4 PROM	Not Field-Replaceable
U7	Quad Op Amp, TL074	54-132
U8	Quad Ex. OR Gate, 74LS86	54-125
U9	Dual Volt. Comp., LM393	54-158

MISCELLANEOUS

REF. DES.	DESCRIPTION	WILTRON PART NO.
---	Ejector, PC Board	553-96
TP1 thru TP4	Pin, Test Point	706-44
K1	Relay, 2 Form C	690-28
---	Socket, I.C., 24-Pin	553-67

Table 6-17. A7 YIG Driver, 8-12.4 GHz, 6653A/6659A (660-D-8009-9, -12)

CAPACITORS			DIODES		
REF. DES.	DESCRIPTION	WILTRON PART NO.	REF. DES.	DESCRIPTION	WILTRON PART NO.
C1	Tantalum, 4.7 μ F	250-39	C13	Monolithic, .1 μ F	230-37
C2	Tantalum, 4.7 μ F	250-39	C14	Disc Ceramic, .01 μ F	230-11
C3	Tantalum, 4.7 μ F	250-39	C16	Monolithic, .1 μ F	230-37
C4	Disc Ceramic, .01 μ F	230-11	C17	Disc Ceramic, .01 μ F	230-11
C5	Disc Ceramic, .001 μ F	230-30	C18	Disc Ceramic, .01 μ F	230-11
C6	Tantalum, 1 μ F, 35V	250-19	C19	Disc Ceramic, .01 μ F	230-11
C7	Tantalum, 1 μ F, 35V	250-19	C20	Mica, 820 pF	220-820
C8	Monolithic, 1.0 μ F	230-41			
C9	Mica, 300 pF	220-300			
C10	Monolithic, .1 μ F	230-37			
C11	Tantalum, 6.8 μ F	250-41			
C12	Mica, 5 pF	220-5			

CR5	Silicon, SI2	10-SI2
CR6	Silicon, 1N4446	10-1N4446
CR7	Silicon, 1N4446	10-1N4446
CR8	Silicon, 1N4446	10-1N4446
CR9	Zener, 10V, 0.4W, 1N758A	10-1N758A
CR10	Silicon, 1N4446	10-1N4446
CR11	Silicon, 1N4446	10-1N4446

TRANSISTORS

REF. DES.	DESCRIPTION	WILTRON PART NO.
Q1	PNP, MPSA92	20-MPSA92
Q2	PNP, MPSA92	20-MPSA92
Q3	PNP, 2N3694	20-2N3694
Q4	NPN, 2N2222A	20-2N2222A
Q5	NPN, 2N2222A	20-2N2222A
Q6	PNP, 2N2907A	20-2N2907A
Q7	NPN, 2N2222A	20-2N2222A

RESISTORS

REF. DES.	DESCRIPTION	WILTRON PART NO.
R1	CC, 1/4W, 5%, 3.3 M Ω	101-3.3M-5
R2	Variable, 15-Turn, 50 k Ω	157-50k
R3	CC, 1/4W, 5%, 3.6 M Ω	101-3.6M-5
R4	MF, 1/4W, 1%, 61.9 k Ω	110-61.9k-1
R5	Variable, 15-Turn, 1 k Ω	157-1k
R7	Variable, 15-Turn, 1 k Ω	157-1k
R9	Variable, 15-Turn, 200 k Ω	157-200k
R10	MF, 1/4W, 1%, 205 k Ω	110-205k-1
R11 ¹	MF, 1/4W, 1%, 14.7 k Ω	110-14.7k-1
R11 ²	MF, 1/4W, 1%, 14 k Ω	110-14k-1
R12	MF, 1/4W, 1%, 20 k Ω	110-20k-1
R13	Variable, 1-Turn, 20 k Ω	156-20k
R14	MF, 1/4W, 1%, 2.61 k Ω	110-2.61k-1
R15	MF, 1/4W, 1%, 10 k Ω	110-10k-1
R16	MF, 1/4W, 1%, 4.99 k Ω	110-4.99k-1
R17	MF, 1/4W, 1%, 10 k Ω	110-10k-1
R18	MF, 1/4W, 1%, 23.7 k Ω	110-23.7k-1
R19	MF, 1/4W, 1%, 1 k Ω	110-1k-1
R20	MF, 1/4W, 1%, 121 Ω	110-121-1
R21	MF, 1/4W, 1%, 1 k Ω	110-1k-1
R22	MF, 1/4W, 1%, 7.5 k Ω	110-7.5k-1
R23	MF, 1/4W, 1%, 511 Ω	110-511-1
R24	MF, 1/4W, 1%, 5.11 k Ω	110-5.11k-1
R25	WW, 5W, 5 Ω	131-3
R26	MF, 1/4W, 1%, 10 k Ω	110-10k-1
R27	MF, 1/4W, 1%, 750 Ω	110-750-1
R28	MF, 1/4W, 1%, 5.49 k Ω	110-5.49k-1
R29	MF, 1/4W, 1%, 1.78 k Ω	110-1.78k-1
R30	MF, 1/4W, 1%, 2.15 k Ω	110-2.15k-1
R31	MF, 1/4W, 1%, 1 k Ω	110-1k-1
R32	MF, 1/4W, 1%, 1.21 k Ω	110-1.21k-1
R33	MF, 1/4W, 1%, 17.8 k Ω	110-17.8k-1
R34	Variable, 1-Turn, 200 k Ω	156-200k
R35	MF, 1/4W, 1%, 1 k Ω	110-1k-1
R38	MF, 1/4W, 1%, 18.7 k Ω	110-18.7k-1
R39	MF, 1/4W, 1%, 18.7 k Ω	110-18.7k-1
R42	Variable, 15-Turn, 50 k Ω	157-50k
R43	MF, 1/4W, 1%, 18.7 k Ω	110-18.7k-1
R44	MF, 1/4W, 1%, 18.7 k Ω	110-18.7k-1
R45	MF, 1/4W, 1%, 10 k Ω	110-10k-1
R46	MF, 1/4W, 1%, 9.53 k Ω	110-9.53k-1

¹Used on 660-D-8009-9 assembly.
²Used on 660-D-8009-12 assembly.

R47	Variable, 15-Turn, 1 k Ω	157-1k
R48	MF, 1/4W, 1%, 11 k Ω	110-11k-1
R49	MF, 1/4W, 1%, 10 k Ω	110-10k-1
R50	MF, 1/4W, 1%, 511 Ω	110-511-1
R51	MF, 1/4W, 1%, 4.99 k Ω	110-4.99k-1
R52	MF, 1/4W, 1%, 3.83 k Ω	110-3.83k-1
R53	MF, 1/4W, 1%, 1 k Ω	110-1k-1
R54	MF, 1/4W, 1%, 511 Ω	110-511-1
R55	MF, 1/4W, 1%, 6.19 Ω	110-6.19-1
R56	MF, 1/4W, 1%, 6.19 Ω	110-6.19-1
R57	MF, 1/4W, 1%, 6.19 Ω	110-6.19-1
R58	MF, 1/4W, 1%, 6.19 Ω	110-6.19-1
R59	MF, 1/4W, 1%, 6.19 Ω	110-6.19-1
R60	MF, 1/4W, 1%, 2.15 k Ω	110-2.15k-1
R61 ¹	MF, 1/4W, 1%, 33.2 k Ω	110-33.2k-1
R61 ²	MF, 1/4W, 1%, 38.3 k Ω	110-38.3k-1
R62 ¹	MF, 1/4W, 1%, 33.2 k Ω	110-33.2k-1
R62 ²	MF, 1/4W, 1%, 38.3 k Ω	110-38.3k-1
R63	MF, 1/4W, 1%, 10 k Ω	110-10k-1
R64	MF, 1/4W, 1%, 10 k Ω	110-10k-1
R65	MF, 1/4W, 1%, 750 k Ω	110-750k-1
R66	MF, 1/4W, 1%, 14.7 k Ω	110-14.7k-1
R67	MF, 1/4W, 1%, 2.26 k Ω	110-2.26k-1
R68	Variable, 15-Turn, 500 Ω	157-500
R69	MF, 1/4W, 1%, 2 k Ω	110-2k-1
R70	MF, 1/4W, 1%, 10 k Ω	110-10k-1
R71	MF, 1/4W, 1%, 750 k Ω	110-750k-1
R72	MF, 1/4W, 1%, 14.7 k Ω	110-14.7k-1
R73	MF, 1/4W, 1%, 10 k Ω	110-10k-1
R74	MF, 1/4W, 1%, 10 k Ω	110-10k-1
R75	MF, 1/4W, 1%, 205 k Ω	110-205k-1
R76	MF, 1/4W, 1%, 511 Ω	110-511-1
R77	Variable, 1-Turn, 20 Ω	156-20
R78	MF, 1/4W, 1%, 2 k Ω	110-2k-1
R79	MF, 1/4W, 1%, 15 k Ω	110-15k-1
R80	MF, 1/4W, 1%, 511 Ω	110-511-1
R81	MF, 1/4W, 1%, 511 Ω	110-511-1
R82	MF, 1/4W, 1%, 100 k Ω	110-100k-1
R83	MF, 1/4W, 1%, 100 k Ω	110-100k-1
R84	MF, 1/4W, 1%, 5.11 k Ω	110-5.11k-1
R85	MF, 1/4W, 1%, 5.11 k Ω	110-5.11k-1
R86	MF, 1/4W, 1%, 5.11 Ω	110-5.11-1

INTEGRATED CIRCUITS

REF. DES.	DESCRIPTION	WILTRON PART NO.
U1	Quad Analog Switch, LF13201	54-20
U2	NAND Gate, 74LS10	54-42
U3	Op Amp, OP05	54-87
U4	Quad Op Amp, TL072	54-53
U5	2k x 8 EPROM	Not Field-Replaceable
U7	Quad Op Amp, TL074	54-132
U8	Quad Ex. OR Gate, 74LS86	54-125
U9	Dual Volt. Comp., LM393	54-158

MISCELLANEOUS

REF. DES.	DESCRIPTION	WILTRON PART NO.
---	Ejector, PC Board	553-96
TP1 thru TP4	Pin, Test Point	706-44
K1	Relay, 2 Form C	690-28
---	Socket, I.C., 24-Pin	553-67

Table 6-18. A8 YIG Driver, 12.4-18.6 GHz, 6653A/6659A (660-D-8009-10, -13)

<u>CAPACITORS</u>					
REF. DES.	DESCRIPTION	WILTRON PART NO.			
C1	Tantalum, 4.7 μ F	250-39	R5	Variable, 15-Turn, 1 k Ω	157-1k
C2	Tantalum, 4.7 μ F	250-39	R7	Variable, 15-Turn, 1 k Ω	157-1k
C3	Tantalum, 4.7 μ F	250-39	R9	Variable, 15-Turn, 200 k Ω	157-200k
C4	Disc Ceramic, .01 μ F	230-11	R10	MF, 1/4W, 1%, 205 k Ω	110-205k-1
C5	Disc Ceramic, .001 μ F	230-30	R11 ¹	MF, 1/4W, 1%, 6.19 k Ω	110-6.19k-1
C6	Tantalum, 1 μ F, 35V	250-19	R11 ²	MF, 1/4W, 1%, 6.81 k Ω	110-6.81k-1
C7	Tantalum, 1 μ F, 35V	250-19	R12	MF, 1/4W, 1%, 20 k Ω	110-20k-1
C8	Monolithic, 1.0 μ F	230-41	R13	Variable, 1-Turn, 20 k Ω	156-20k
C9	Mica, 300 pF	220-300	R14 ¹	MF, 1/4W, 1%, 1.78 k Ω	110-1.78k-1
C10	Monolithic, .1 μ F	230-37	R14 ²	MF, 1/4W, 1%, 1.87 k Ω	110-1.87k-1
C11	Tantalum, 6.8 μ F	250-41A	R15	MF, 1/4W, 1%, 10 k Ω	110-10k-1
C12	Mica, 5 pF	220-5	R16	MF, 1/4W, 1%, 4.99 k Ω	110-4.99k-1
C13	Monolithic, .1 μ F	230-37	R17	MF, 1/4W, 1%, 10 k Ω	110-10k-1
C14	Disc Ceramic, .01 μ F	230-11	R18	MF, 1/4W, 1%, 23.7 k Ω	110-23.7k-1
C16	Monolithic, .1 μ F	230-37	R19	MF, 1/4W, 1%, 1 k Ω	110-1k-1
C17	Disc Ceramic, .01 μ F	230-11	R20	MF, 1/4W, 1%, 121 Ω	110-121-1
C18	Disc Ceramic, .01 μ F	230-11	R21	MF, 1/4W, 1%, 1 k Ω	110-1k-1
C19	Disc Ceramic, .01 μ F	230-11	R22	MF, 1/4W, 1%, 7.5 k Ω	110-7.5k-1
C20	Mica, 820 pF	220-820	R23	MF, 1/4W, 1%, 511 Ω	110-511-1
			R24	MF, 1/4W, 1%, 5.11 k Ω	110-5.11k-1
			R25	WW, 5W, 2 Ω	131-1
			R26	MF, 1/4W, 1%, 10 k Ω	110-10k-1
			R27	MF, 1/4W, 1%, 750 Ω	110-750-1
			R28	MF, 1/4W, 1%, 5.49 k Ω	110-5.49k-1
			R29	MF, 1/4W, 1%, 1.78 k Ω	110-1.78k-1
			R30	MF, 1/4W, 1%, 2.15 k Ω	110-2.15k-1
			R31	MF, 1/4W, 1%, 1 k Ω	110-1k-1
			R32	MF, 1/4W, 1%, 1.21 k Ω	110-1.21k-1
			R33	MF, 1/4W, 1%, 17.8 k Ω	110-17.8k-1
			R34	Variable, 1-Turn, 200 k Ω	156-200k
			R35	MF, 1/4W, 1%, 1 k Ω	110-1k-1
			R38	MF, 1/4W, 1%, 18.7 k Ω	110-18.7k-1
			R39	MF, 1/4W, 1%, 18.7 k Ω	110-18.7k-1
			R42	Variable, 15-Turn, 50 k Ω	157-50k
			R43	MF, 1/4W, 1%, 18.7 k Ω	110-18.7k-1
			R44	MF, 1/4W, 1%, 18.7 k Ω	110-18.7k-1
			R45	MF, 1/4W, 1%, 10 k Ω	110-10k-1
			R46	MF, 1/4W, 1%, 9.53 k Ω	110-9.53k-1
			R47	Variable, 15-Turn, 1 k Ω	157-1k
			R48	MF, 1/4W, 1%, 11 k Ω	110-11k-1
			R49	MF, 1/4W, 1%, 10 k Ω	110-10k-1
			R50	MF, 1/4W, 1%, 511 Ω	110-511-1
			R51	MF, 1/4W, 1%, 4.99 k Ω	110-4.99k-1
			R52	MF, 1/4W, 1%, 3.83 k Ω	110-3.83k-1
			R53	MF, 1/4W, 1%, 1 k Ω	110-1k-1
			R54	MF, 1/4W, 1%, 511 Ω	110-511-1
			R55	MF, 1/4W, 1%, 6.19 Ω	110-6.19-1
			R56	MF, 1/4W, 1%, 6.19 Ω	110-6.19-1
			R57	MF, 1/4W, 1%, 6.19 Ω	110-6.19-1
			R58	MF, 1/4W, 1%, 6.19 Ω	110-6.19-1
			R59	MF, 1/4W, 1%, 6.19 Ω	110-6.19-1
			R60	MF, 1/4W, 1%, 2.15 k Ω	110-2.15k-1
			R61	MF, 1/4W, 1%, 100 k Ω	110-100k-1
			R63	MF, 1/4W, 1%, 10 k Ω	110-10k-1
			R64	MF, 1/4W, 1%, 10 k Ω	110-10k-1
			R65	MF, 1/4W, 1%, 750 k Ω	110-750k-1
			R66	MF, 1/4W, 1%, 14.7 k Ω	110-14.7k-1
			R67	MF, 1/4W, 1%, 825 Ω	110-825-1
			R68	Variable, 15-Turn, 500 Ω	157-500
			R69	MF, 1/4W, 1%, 2 k Ω	110-2k-1
			R70	MF, 1/4W, 1%, 10 k Ω	110-10k-1
			R71	MF, 1/4W, 1%, 750 k Ω	110-750k-1
			R72	MF, 1/4W, 1%, 14.7 k Ω	110-14.7k-1
			R73	MF, 1/4W, 1%, 10 k Ω	110-10k-1
			R74	MF, 1/4W, 1%, 10 k Ω	110-10k-1
			R75	MF, 1/4W, 1%, 205 k Ω	110-205k-1
			R76	MF, 1/4W, 1%, 511 Ω	110-511-1
			R77	Variable, 1-Turn, 20 Ω	156-20

<u>DIODES</u>		
REF. DES.	DESCRIPTION	WILTRON PART NO.
CR1	Silicon, 1N4446	10-1N4446
CR2	Silicon, 1N4446	10-1N4446
CR3	Silicon, SI2	10-SI2
CR4	Zener, 24V, 1W, 1N4749A	10-1N4749A
CR5	Silicon, SI2	10-SI2
CR6	Silicon, 1N4446	10-1N4446
CR7	Silicon, 1N4446	10-1N4446
CR8	Silicon, 1N4446	10-1N4446
CR9	Zener, 10V, 0.4W, 1N758A	10-1N758A
CR10	Silicon, 1N4446	10-1N4446
CR11	Silicon, 1N4446	10-1N4446

<u>TRANSISTORS</u>		
REF. DES.	DESCRIPTION	WILTRON PART NO.
Q1	PNP, MPSA92	20-MPSA92
Q2	PNP, MPSA92	20-MPSA92
Q3	PNP, 2N3694	20-2N3694
Q4	NPN, 2N2222A	20-2N2222A
Q5	NPN, 2N2222A	20-2N2222A
Q6	PNP, 2N2907A	20-2N2907A
Q7	NPN, 2N2222A	20-2N2222A

<u>RESISTORS</u>		
REF. DES.	DESCRIPTION	WILTRON PART NO.
R1	CC, 1/4W, 5%, 3.3 M Ω	101-3.3M-5
R2	Variable, 15-Turn, 50 k Ω	157-50k
R3	CC, 1/4W, 5%, 3.6 M Ω	101-3.6M-5
R4	MF, 1/4W, 1%, 61.9 k Ω	110-61.9k-1

¹Used on 660-D-8009-10 assembly.
²Used on 660-D-8009-13 assembly.

R27	MF, 1/4W, 1%, 750Ω	110-750-1	R73	MF, 1/4W, 1%, 10 kΩ	110-10k-1
R28	MF, 1/4W, 1%, 5.49 kΩ	110-5.49k-1	R74	MF, 1/4W, 1%, 10 kΩ	110-10k-1
R29	MF, 1/4W, 1%, 1.78 kΩ	110-1.78k-1	R75	MF, 1/4W, 1%, 205 kΩ	110-205k-1
R30	MF, 1/4W, 1%, 2.15 kΩ	110-2.15k-1	R76	MF, 1/4W, 1%, 511Ω	110-511-1
R31	MF, 1/4W, 1%, 1 kΩ	110-1k-1	R77	Variable, 1-Turn, 20Ω	156-20
R32	MF, 1/4W, 1%, 1.21 kΩ	110-1.21k-1	R78	MF, 1/4W, 1%, 2 kΩ	110-2k-1
R33	MF, 1/4W, 1%, 17.8 kΩ	110-17.8k-1	R79	MF, 1/4W, 1%, 15 kΩ	110-15k-1
R34	Variable, 1-Turn, 200 kΩ	156-200k	R80	MF, 1/4W, 1%, 511Ω	110-511-1
R35	MF, 1/4W, 1%, 1 kΩ	110-1k-1	R81	MF, 1/4W, 1%, 511Ω	110-511-1
R38	MF, 1/4W, 1%, 18.7 kΩ	110-18.7k-1	R82	MF, 1/4W, 1%, 100 kΩ	110-100k-1
R39	MF, 1/4W, 1%, 18.7 kΩ	110-18.7k-1	R83	MF, 1/4W, 1%, 100 kΩ	110-100k-1
R42	Variable, 15-Turn, 50 kΩ	157-50k	R84	MF, 1/4W, 1%, 5.11 kΩ	110-5.11k-1
R43	MF, 1/4W, 1%, 18.7 kΩ	110-18.7k-1	R85	MF, 1/4W, 1%, 5.11 kΩ	110-5.11k-1
R44	MF, 1/4W, 1%, 18.7 kΩ	110-18.7k-1	R86	MF, 1/4W, 1%, 5.11Ω	110-5.11-1
R45	MF, 1/4W, 1%, 10 kΩ	110-10k-1			
R46	MF, 1/4W, 1%, 9.53 kΩ	110-9.53k-1			
R47	Variable, 15-Turn, 1 kΩ	157-1k			
R48	MF, 1/4W, 1%, 11 kΩ	110-11k-1			
R49	MF, 1/4W, 1%, 10 kΩ	110-10k-1			
R50	MF, 1/4W, 1%, 511Ω	110-511-1			
R51	MF, 1/4W, 1%, 4.99 kΩ	110-4.99k-1			
R52	MF, 1/4W, 1%, 3.83 kΩ	110-3.83k-1			
R53	MF, 1/4W, 1%, 1 kΩ	110-1k-1			
R54	MF, 1/4W, 1%, 511Ω	110-511-1			
R55	MF, 1/4W, 1%, 6.19Ω	110-6.19-1			
R56	MF, 1/4W, 1%, 6.19Ω	110-6.19-1			
R57	MF, 1/4W, 1%, 6.19Ω	110-6.19-1			
R58	MF, 1/4W, 1%, 6.19Ω	110-6.19-1			
R59	MF, 1/4W, 1%, 6.19Ω	110-6.19-1			
R60	MF, 1/4W, 1%, 2.15 kΩ	110-2.15k-1			
R61	MF, 1/4W, 1%, 12.1 kΩ	110-12.1k-1			
R63	MF, 1/4W, 1%, 10 kΩ	110-10k-1			
R64	MF, 1/4W, 1%, 10 kΩ	110-10k-1			
R65	MF, 1/4W, 1%, 750 kΩ	110-750k-1			
R66	MF, 1/4W, 1%, 14.7 kΩ	110-14.7k-1			
R67	MF, 1/4W, 1%, 5.11Ω	110-5.11-1			
R68	Variable, 15-Turn, 500Ω	157-500			
R69	MF, 1/4W, 1%, 2 kΩ	110-2k-1			
R70	MF, 1/4W, 1%, 10 kΩ	110-10k-1			
R71	MF, 1/4W, 1%, 750 kΩ	110-750k-1			
R72	MF, 1/4W, 1%, 14.7 kΩ	110-14.7k-1			

INTEGRATED CIRCUITS					
REF. DES.	DESCRIPTION	WILTRON PART NO.			
U1	Quad Analog Switch, LF13201	54-20			
U2	NAND Gate, 74LS10	54-42			
U3	Op Amp, OP05	54-87			
U4	Quad Op Amp, TL072	54-53			
U5	2k x 8 EPROM	Not Field-Replaceable			
U7	Quad Op Amp, TL074	54-132			
U8	Quad Ex. OR Gate, 74LS86	54-125			
U9	Dual Volt. Comp., LM393	54-158			

MISCELLANEOUS					
REF. DES.	DESCRIPTION	WILTRON PART NO.			
---	Ejector, PC Board	553-96			
TP1 thru TP4	Pin, Test Point	706-44			
K1	Relay, 2 Form C	690-28			
---	Socket, I.C., 24-Pin	553-67			

Table 6-20. A10 FM/Attenuator (660-D-8010)

CAPACITORS			DIODES		
REF. DES.	DESCRIPTION	WILTRON PART NO.	REF. DES.	DESCRIPTION	WILTRON PART NO.
C1	Mica, 130 pF	220-130	C18	Tantalum, 25V, 10 μF	250-42
C2	Monolithic, .1 μF	230-37	C19	Tantalum, 25V, 10 μF	250-42
C3	Monolithic, .1 μF	230-37	C20	Tantalum, 25V, 10 μF	250-42
C4	Monolithic, .1 μF	230-37	C21	Monolithic, .1 μF	230-37
C5	Monolithic, .1 μF	230-37	C22	Monolithic, .1 μF	230-37
C6	Monolithic, .1 μF	230-37	C23	Tantalum, 6V, 68 μF	250-58
C7 ¹	Monolithic, .1 μF	230-37	C24	Ceramic Disc .01 μF	230-11
C8	Mica, 8 pF	220-8	C25	Ceramic Disc .01 μF	230-11
C9	Tantalum, 25V, 10 μF	250-42	C26	Mica, 8 pF	220-8
C10	Tantalum, 25V, 10 μF	250-42	C27	Tantalum, 25V, 10 μF	250-42
C11	Ceramic Disc, .001 μF	230-30	C28	Tantalum, 25V, 10 μF	250-42
C12	Mica, 8 pF	220-8	C29	Ceramic, .0047 μF	230-36
C13	Monolithic, .1 μF	230-37	C30	Mica, 8 pF	220-8
C14	Monolithic, .1 μF	230-37			
C15	Mica, 8 pF	220-8			
C16	Mica, 8 pF	220-8			
C17	Tantalum, 25V, 10 μF	250-42			

¹.01 μF, 230-11, 6637A-40 only.

CR5	Silicon, 1N4446	10-1N4446
CR6	Silicon, 1N4446	10-1N4446
CR7	Zener, 3.3V, 0.4W, 1N746A	10-1N746A
CR8	Zener, 3.3V, 0.4W, 1N746A	10-1N746A
CR9	Silicon, 1N4446	10-1N4446
CR10	Silicon, 1N4446	10-1N4446
CR11	Silicon, 1N4446	10-1N4446
CR12	Silicon, 1N4446	10-1N4446
CR13	Silicon, 1N4446	10-1N4446
CR14	Zener, 4.7V, 0.4W, 1N750A	10-11
CR15	Zener, 4.7V, 0.4W, 1N750A	10-11
CR16	Silicon, 1N4446	10-1N4446
CR17	Silicon, 1N4446	10-1N4446
CR18	Silicon, 1N4446	10-1N4446
CR19	Silicon, 1N4446	10-1N4446
CR20	Silicon, 1N4446	10-1N4446
CR21	Silicon, 1N4446	10-1N4446
CR22	Silicon, 1N4446	10-1N4446
CR23	Silicon, 1N4446	10-1N4446
CR24	Silicon, 1N4446	10-1N4446
CR25	Silicon, 1N4446	10-1N4446
CR26	Silicon, 1N4446	10-1N4446
CR27	Silicon, 1N4446	10-1N4446
CR28	Silicon, 1N4446	10-1N4446
CR29	Silicon, 1N4446	10-1N4446
CR30	Silicon, 1N4446	10-1N4446
CR31	Silicon, 1N4446	10-1N4446
CR32	Silicon, 1N4446	10-1N4446

TRANSISTORS

REF. DES.	DESCRIPTION	WILTRON PART NO.
Q1	PNP, 10W, 2N6552	20-3
Q2	NPN, 10W, 2N6555	20-4
Q3	PNP, 10W, 2N6552	20-3
Q4	NPN, 10W, 2N6555	20-4
Q5	NPN, 50W, TIP110	20-22
Q6	PNP, 50W, TIP115	20-23

RESISTORS

REF. DES.	DESCRIPTION	WILTRON PART NO.
R1	MF, 1/4W, 1%, 14.3 kΩ	110-14.3k-1
R2	MF, 1/4W, 1%, 14.3 kΩ	110-14.3k-1
R3	MF, 1/4W, 1%, 100 kΩ	110-100k-1
R4	MF, 1/4W, 1%, 10 kΩ	110-10k-1
R5	MF, 1/4W, 1%, 10 kΩ	110-10k-1
R6	MF, 1/4W, 1%, 1 kΩ	110-1k-1
R7	MF, 1/4W, 1%, 1 kΩ	110-1k-1
R8	MF, 1/4W, 1%, 1 kΩ	110-1k-1
R9	MF, 1/4W, 1%, 1 kΩ	110-1k-1
R10	Variable, 5k, 1-Turn	156-5k
R11	Variable, 5k, 1-Turn	156-5k
R12	Variable, 5k, 1-Turn	156-5k
R13	Variable, 5k, 1-Turn	156-5k
R14	MF, 1/4W, 1%, 7.32 kΩ	110-7.32k-1
R15	MF, 1/4W, 1%, 4.99 kΩ	110-4.99k-1
R16	MF, 1/4W, 1%, 4.99 kΩ	110-4.99k-1
R17	MF, 1/4W, 1%, 100Ω	110-100-1
R18	MF, 1/4W, 1%, 4.99 kΩ	110-4.99k-1

R19	MF, 1/4W, 1%, 4.99 kΩ	110-4.99k-1
R20	MF, 1/4W, 1%, 16.5 kΩ	110-16.5k-1
R21	Not Used	
R22	MF, 1/4W, 1%, 10 kΩ	110-10k-1
R23	MF, 1/4W, 1%, 10 kΩ	110-10k-1
R24	MF, 1/4W, 1%, 100 kΩ	110-100k-1
R25	MF, 1/4W, 1%, 10 kΩ	110-10k-1
R26	MF, 1/4W, 1%, 10 kΩ	110-10k-1
R27	MF, 1/4W, 1%, 8.87 kΩ	110-8.87k-1
R28	MF, 1/4W, 1%, 49.9 kΩ	110-49.9-1
R29	MF, 1/4W, 1%, 2.8 kΩ	110-2.8k-1
R30	MF, 1/4W, 1%, 14.7Ω	110-14.7-1
R31	MF, 1/4W, 1%, 14.7Ω	110-14.7-1
R32	MF, 1/4W, 1%, 14.7Ω	110-14.7-1
R33	MF, 1/4W, 1%, 14.7Ω	110-14.7-1
R34	MF, 1/4W, 1%, 14.7Ω	110-14.7-1
R35	MF, 1/4W, 1%, 14.7Ω	110-14.7-1
R36	MF, 1/4W, 1%, 2.8 kΩ	110-2.8k-1
R37	MF, 1/4W, 1%, 42.2Ω	110-42.2-1
R38	MF, 1/4W, 1%, 42.2Ω	110-42.2-1
R39	MF, 1/4W, 1%, 42.2Ω	110-42.2-1
R40	MF, 1/4W, 1%, 42.2Ω	110-42.2-1
R41	MF, 1/4W, 1%, 10 kΩ	110-10k-1
R42	MF, 1/4W, 1%, 9.76 kΩ	110-9.76k-1
R43	MF, 1/4W, 1%, 3.65 kΩ	110-3.65k-1
R44	MF, 1/4W, 1%, 80.6Ω	110-80.6-1
R45	MF, 1/4W, 1%, 80.6Ω	110-80.6-1
R46	MF, 1/4W, 1%, 34.8Ω	110-34.8-1
R47	MF, 1/4W, 1%, 34.8Ω	110-34.8-1
R48	MF, 1/4W, 1%, 34.8Ω	110-34.8-1
R49	MF, 1/4W, 1%, 34.8Ω	110-34.8-1
R50	MF, 1/4W, 1%, 3.65 kΩ	110-3.65k-1
R51	MF, 1/4W, 1%, 121Ω	110-121-1
R52	MF, 1/4W, 1%, 121Ω	110-121-1
R53	MF, 1/4W, 1%, 121Ω	110-121-1
R54	MF, 1/4W, 1%, 121Ω	110-121-1
R55	MF, 1/4W, 1%, 10 kΩ	110-10k-1
R56	MF, 1/4W, 1%, 10 kΩ	110-10k-1
R57	MF, 1/4W, 1%, 10 kΩ	110-10k-1
R58	MF, 1/4W, 1%, 10 kΩ	110-10k-1
R59	MF, 1/4W, 1%, 10 kΩ	110-10k-1
R60	MF, 1/4W, 1%, 10 kΩ	110-10k-1
R61	Variable, 10k, 1-Turn	156-10k
R62	Variable, 10k, 1-Turn	156-10k
R63	MF, 1/4W, 1%, 46.4 kΩ	110-46.4k-1
R64	MF, 1/4W, 1%, 8.25 kΩ	110-8.25k-1
R65	MF, 1/4W, 1%, 100Ω	110-100-1
R66	MF, 1/4W, 1%, 3.65 kΩ	110-3.65k-1
R67	MF, 1/4W, 1%, 3.65 kΩ	110-3.65k-1
R68	WW, 3W, 5Ω	130-5-3
R69	WW, 3W, 5Ω	130-5-3
R70	WW, 3W, 5Ω	130-5-3
R71	MF, 1/4W, 1%, 10 kΩ	110-10k-1
R72	MF, 1/4W, 1%, 10 kΩ	110-10k-1
R73	MF, 1/4W, 1%, 9.76 kΩ	110-9.76k-1
R74	MF, 1/4W, 1%, 10 kΩ	110-10k-1
R75	MF, 1/4W, 1%, 8.82 kΩ	110-8.82k-1

INTEGRATED CIRCUITS

REF. DES.	DESCRIPTION	WILTRON PART NO.
U1	Quad Exclusive OR 74LS86	54-125
U2	Comparator, LM311H	54-30
U3	Comparator, LM311H	54-30
U4	Op Amp, LF357	50-7
U5	Quad Switch DG201CJ	54-24

Q3	PNP, 2N2907	20-2N2907
Q4	PNP, 2N2907	20-2N2907
Q5	PNP, 2N2907	20-2N2907
Q6	PNP, 2N2907	20-2N2907
Q7	PNP, 2N2907	20-2N2907
Q8	PNP, 2N2907	20-2N2907
Q9	PNP, 2N2907	20-2N2907
Q10	PNP, 2N2907	20-2N2907
Q11	PNP, 2N2907	20-2N2907
Q12	PNP, 2N2907	20-2N2907
Q13	PNP, 2N2907	20-2N2907
Q14	PNP, 2N2907	20-2N2907
Q15	PNP, 2N2907	20-2N2907

RESISTORS

REF. DES.	DESCRIPTION	WILTRON PART NO.
R1	MF, 1/4W, 1%, 215Ω	110-215-1
R2	MF, 1/4W, 1%, 215Ω	110-215-1
R3	MF, 1/4W, 1%, 215Ω	110-215-1
R4	Not Used	
R5	MF, 1/4W, 1%, 215Ω	110-215-1
R6	MF, 1/4W, 1%, 215Ω	110-215-1
R7	MF, 1/4W, 1%, 215Ω	110-215-1
R8	Not Used	
R9	MF, 1/4W, 1%, 215Ω	110-215-1
R10	MF, 1/4W, 1%, 215Ω	110-215-1
R11	MF, 1/4W, 1%, 215Ω	110-215-1
R12	MF, 1/4W, 1%, 215Ω	110-215-1
R13	MF, 1/4W, 1%, 215Ω	110-215-1
R14	MF, 1/4W, 1%, 215Ω	110-215-1
R15	MF, 1/4W, 1%, 215Ω	110-215-1
R16	MF, 1/4W, 1%, 215Ω	110-215-1
R17	MF, 1/4W, 1%, 215Ω	110-215-1
R18	MF, 1/4W, 1%, 215Ω	110-215-1
R19	Not Used	
R20	MF, 1/4W, 1%, 215Ω	110-215-1
R21	MF, 1/4W, 1%, 215Ω	110-215-1
R22	MF, 1/4W, 1%, 215Ω	110-215-1
R23	MF, 1/4W, 1%, 215Ω	110-215-1
R24	MF, 1/4W, 1%, 147Ω	110-147-1
R25	MF, 1/4W, 1%, 147Ω	110-147-1
R26	MF, 1/4W, 1%, 147Ω	110-147-1
R27	MF, 1/4W, 1%, 147Ω	110-147-1
R28	MF, 1/4W, 1%, 147Ω	110-147-1
R29	MF, 1/4W, 1%, 147Ω	110-147-1
R30	MF, 1/4W, 1%, 147Ω	110-147-1
R31	MF, 1/4W, 1%, 147Ω	110-147-1
R32	MF, 1/4W, 1%, 215Ω	110-215-1
R33	MF, 1/4W, 1%, 4.64k	110-4.64k-1
R34	MF, 1/4W, 1%, 215Ω	110-215-1
R35	MF, 1/4W, 1%, 215Ω	110-215-1
R36	MF, 1/4W, 1%, 215Ω	110-215-1
R37	MF, 1/4W, 1%, 215Ω	110-215-1
R38	MF, 1/4W, 1%, 10k	110-10k-1
R39	Not Used	
R40	Variable, 20k	146-3
R41	Variable, 20k	146-3
R42	Not Used	
R43	Variable, 20k	146-5
RP1	DIP, 56Ω	123-11
RP2	DIP, 220Ω	123-12
RP3	DIP, 220Ω	123-12
RP4	DIP, 220Ω	123-13
RP5	SIP, 220Ω	123-14
RP6	SIP, 220Ω	123-14
RP7	SIP, 4.7k	123-15
RP8	SIP, 4.7k	123-15

SWITCHES

REF. DES.	DESCRIPTION	WILTRON PART NO.
S1	SPST, Momentary	430-130
S2	SPST, Momentary	430-130
S3	SPST, Momentary	430-130
S4	SPST, Momentary	430-130
S5	SPST, Momentary	430-130
S6	SPST, Momentary	430-130
S7	SPST, Momentary	430-130
S8	SPST, Momentary	430-130
S9	SPST, Momentary	430-130
S10	SPST, Momentary	430-130
S11	SPST, Momentary	430-130
S12	SPST, Momentary	430-130
S13	DPST, Momentary	430-131
S14	DPST, Momentary	430-131
S15	SPST, Momentary	430-130
S16	SPST, Momentary	430-130
S17	DPST, Momentary	430-131
S18	SPST, Momentary	430-130
S19	SPST, Momentary	430-130
S20	Not Used	
S21	Not Used	
S22	SPST, Momentary	430-130
S23	SPST, Momentary	430-130
S24	SPST, Momentary	430-130
S25	SPST, Momentary	430-130
S26	Not Used	
S27	SPST, Momentary	430-130
S28	SPST, Momentary	430-130
S29	SPST, Momentary	430-130
S30	SPST, Momentary	430-130
S31	SPST, Momentary	430-130
S32	SPST, Momentary	430-130
S33	SPST, Momentary	430-130
S34	SPST, Momentary	430-130
S35	SPST, Momentary	430-130
S36	SPST, Momentary	430-130
S37	DPST, Momentary	430-131
S38	DPST, Momentary	430-131
S39	SPST, Momentary	430-130
S40	Not Used	
S41	Not Used	
S42	SPST, Momentary	430-130
S43	SPST, Momentary	430-130
S44	SPST, Momentary	430-130
S45	SPST, Momentary	430-130
S46	SPST, Momentary	430-130
S47	SPST, Momentary	430-130
S48	SPST, Momentary	430-130
S49	SPST, Momentary	430-130
S50	SPST, Momentary	430-130
S51	SPST, Momentary	430-130
S52	SPST, Momentary	430-130
S53	SPST, Momentary	430-130
S54	DPST, Momentary	430-131
S55	SPST, Momentary	430-130
S56	SPST, Momentary	430-130
S57	SPST, Momentary	430-130
S58	SPST, Momentary	430-130

INTEGRATED CIRCUITS

REF. DES.	DESCRIPTION	WILTRON PART NO.
U1	74LS374, Octal Latch	54-41
U2	74LS374, Octal Latch	54-41

U3	74LS374, Octal Latch	54-41
U4	74LS374, Octal Latch	54-41
U5	74LS374, Octal Latch	54-41
U6	74LS374, Octal Latch	54-41
U7	74LS138, 3 to 8 Decoder	54-74LS138
U8	7406, HEX Inverter	54-104
U9	7406, HEX Inverter	54-104
U10	7406, HEX Inverter	54-104
U11	74154, 4 to 16 Decoder	54-147

<u>MISCELLANEOUS</u>		
REF. DES.	DESCRIPTION	WILTRON PART NO.
----	Socket, DIP, 14 Pin	551-143
----	Standoff, Nylon (Long LED)	790-129
----	Standoff, Nylon (Short LED)	790-130
----	Standoff, Nylon (Display LED)	790-131

Table 6-22. A12 Microprocessor (660-D-8012)

<u>CAPACITORS</u>			<u>TRANSISTORS</u>		
REF. DES.	DESCRIPTION	WILTRON PART NO.	REF. DES.	DESCRIPTION	WILTRON PART NO.
C1	Tantalum, 10 μ F, 25V	250-42	Q1	PNP, MJE371	20-24
C2	Tantalum, 10 μ F, 25V	250-42	Q2	NPN, 2N2222A	20-2N2222A
C3	Mylar, 0.047 μ F, 250V	210-28	Q3	NPN, 2N2222A	20-2N2222A
C4	Tantalum, 1 μ F, 35V	250-19	Q4	NPN, 2N2222A	20-2N2222A
C5	Disc Ceramic, 0.01 μ F, 100V	230-11			
C6	Mylar, 0.1 μ F, 250V	210-30			
C7	Disc Ceramic, 0.01 μ F, 100V	230-11			
C8	Disc Ceramic, 0.01 μ F, 100V	230-11			
C9	Disc Ceramic, 0.01 μ F, 100V	230-11			
C10	Monolithic, 0.1 μ F, 50V	230-37			
C11	Monolithic, 0.1 μ F, 50V	230-37			
C12	Monolithic, 0.1 μ F, 50V	230-37			
C13	Monolithic, 0.1 μ F, 50V	230-37			
C14	Monolithic, 0.1 μ F, 50V	230-37			
C15	Monolithic, 0.1 μ F, 50V	230-37			
C16	Monolithic, 0.1 μ F, 50V	230-37			
C17	Monolithic, 0.1 μ F, 50V	230-37			
C18	Monolithic, 0.1 μ F, 50V	230-37			
C19	Monolithic, 0.1 μ F, 50V	230-37			
C20	Monolithic, 0.1 μ F, 50V	230-37			
C22	Monolithic, 0.1 μ F, 50V	230-37			
<u>DIODES</u>			<u>RESISTORS</u>		
REF. DES.	DESCRIPTION	WILTRON PART NO.	REF. DES.	DESCRIPTION	WILTRON PART NO.
CR1	Silicon Rectifier, SI2	10-SI2	R1	MF, 1/4W, 1%, 12.1k	110-12.1k-1
CR2	1N4446	10-1N4446	R2	MF, 1/4W, 1%, 150 Ω	110-150-1
CR3	1N4446	10-1N4446	R3	MF, 1/4W, 1%, 46.4k	110-46.4k-1
CR4	1N4446	10-1N4446	R4	MF, 1/4W, 1%, 10 k Ω	110-10k-1
CR5	1N4446	10-1N4446	R5	MF, 1/4W, 1%, 68.1k	110-68.1k-1
CR6	1N4446	10-1N4446	R6	MF, 1/4W, 1%, 237k	110-237k-1
			R7	MF, 1/4W, 1%, 100k	110-100k-1
			R8	MF, 1/4W, 1%, 10 k Ω	110-10k-1
			R9	MF, 1/4W, 1%, 100k	110-100k-1
			R10	MF, 1/4W, 1%, 1M	110-1M-1A
			R11	CC, 1/2W, 5%, 430 Ω	102-430-5
			R12	MF, 1/4W, 1%, 10 k Ω	110-10k-1
			R13	MF, 1/4W, 1%, 10 k Ω	110-10k-1
			R14	MF, 1/4W, 1%, 10 k Ω	110-10k-1
			R15	MF, 1/4W, 1%, 10 k Ω	110-10k-1
			R16	MF, 1/4W, 1%, 100k	110-100k-1
			R17	MF, 1/4W, 1%, 10 k Ω	110-10k-1
			R18	MF, 1/4W, 1%, 10 k Ω	110-10k-1
			R19	MF, 1/4W, 1%, 10 k Ω	110-10k-1
			R20	MF, 1/4W, 1%, 10 k Ω	110-10k-1
			R21	MF, 1/4W, 1%, 100k	110-100k-1
			R22	MF, 1/4W, 1%, 100k	110-100k-1
			R23	MF, 1/4W, 1%, 100k	110-100k-1
			R24	MF, 1/4W, 1%, 10 k Ω	110-10k-1
			R25	MF, 1/4W, 1%, 10 k Ω	110-10k-1
			R26	MF, 1/4W, 1%, 10 k Ω	110-10k-1
			R27	MF, 1/4W, 1%, 100k	110-100k-1
			R28	MF, 1/4W, 1%, 10 k Ω	110-10k-1
			R29	MF, 1/4W, 1%, 215 Ω	110-215-1
			R30	MF, 1/4W, 1%, 215 Ω	110-215-1
			R31	MF, 1/4W, 1%, 10 k Ω	110-10k-1
			R32	MF, 1/4W, 1%, 10 k Ω	110-10k-1
			R33	MF, 1/4W, 1%, 10 k Ω	110-10k-1
			R34	MF, 1/4W, 1%, 10 k Ω	110-10k-1
			R35	MF, 1/4W, 1%, 10 k Ω	110-10k-1
			R36	MF, 1/4W, 1%, 82.5k	110-82.5k-1
			R37	MF, 1/4W, 1%, 31.6k	110-31.6k-1
			R38	MF, 1/4W, 1%, 10 k Ω	110-10k-1
			R39	MF, 1/4W, 1%, 10 k Ω	110-10k-1
			R40	MF, 1/4W, 1%, 10 k Ω	110-10k-1
<u>CONNECTORS</u>					
REF. DES.	DESCRIPTION	WILTRON PART NO.			
P1	20 Pin, Male	551-215			
P2	20 Pin, Male	551-215			
P3	20 Pin, Male	551-215			
P4	20 Pin, Male	551-215			
P5	26 Pin, Male	551-102			
P6	26 Pin, Male	551-102			
P7	26 Pin, Male	551-102			
P8	3 Pin, Male	551-207			
P9	Plug, DIP, 18 Pin	551-236			

R41	MF, 1/4W, 1%, 20k	110-20k-1
R42	MF, 1/4W, 1%, 20k	110-20k-1
R43	MF, 1/4W, 1%, 31.6k	110-31.6k-1
R44	MF, 1/4W, 1%, 100k	110-100k-1
R45	MF, 1/4W, 1%, 20k	110-20k-1
R46	Variable, Single-Turn, 10k	156-10k
R47	MF, 1/4W, 1%, 20k	110-20k-1
R48	MF, 1/4W, 1%, 100Ω	110-100-1
R49	MF, 1/4W, 1%, 10 kΩ	110-10k-1
R50	MF, 1/4W, 1%, 10 kΩ	110-10k-1
R51	MF, 1/4W, 1%, 1k	110-1k-1
R52	MF, 1/4W, 1%, 10 kΩ	110-10k-1
RP1	SIP, 10k	123-6
RP2	DIP, 100k	123-10

INTEGRATED CIRCUITS

REF. DES.	DESCRIPTION	WILTRON PART NO.
U1	Micropower Comparator	54-151
U2	8085A, Microprocessor	54-93
U3	74LS373, Octal Latch	54-103
U4	74LS138, Decoder	54-74LS138
U5	2716, 2k x 8 EPROM	Contact WILTRON Customer Service
U6	2716, 2k x 8 EPROM	
U7	2716, 2k x 8 EPROM	
U8	2716, 2k x 8 EPROM	
U9	Not Used	
U10	74LS244, Octal Tri-state Driver	54-143
U11	5101L-1, 256x4 CMOS RAM	54-146
U12	5101L-1, 256x4 CMOS RAM	54-146
U13	DP8304B, Bidirectional Bus Driver	54-128
U14	DP8304B, Bidirectional Bus Driver	54-128
U15	74LS04, HEX Inverter	54-74LS04
U16	74LS01, Quad NAND Gate	54-74LS01

U17	Not Used	
U18	74LS138, Decoder	54-74LS138
U19	74LS138, Decoder	54-74LS138
U20	74LS138, Decoder	54-74LS138
U21	74LS138, Decoder	54-74LS138
U22	74LS138, Decoder	54-74LS138
U23	74LS138, Decoder	54-74LS138
U24	74LS30, 8-input NAND	54-58
U25	8279-5, Keyboard/Display Interface	54-97
U26	96L02, Dual Monostable	54-96L02
U27	555, Timer	54-555
U28	74LS161, 4-Bit Binary Counter	54-60
U29	74LS374, Octal Latch	54-41
U30	74LS374, Octal Latch	54-41
U31	74LS374, Octal Latch	54-41
U32	74LS04, HEX Inverter	54-74LS04
U33	74LS04, HEX Inverter	54-74LS04
U34	74LS02, Quad 2-Input NOR	54-57
U35	74LS02, Quad 2-Input NOR	54-57
U36	TL072, Dual Op Amp	54-53
U37	5101L-1, 256 x 4 CMOS RAM	54-146
U38	5101L-1, 256 x 4 CMOS RAM	54-146

MISCELLANEOUS

REF. DES.	DESCRIPTION	WILTRON PART NO.
B1	Battery, 2.4V	633-8
S1	Switch, Slide, SPDT	420-14
Y1	Crystal, 6.000 MHz	630-17
----	Socket, 20 Pin DIP	553-98
----	Socket, 24 Pin DIP	553-67
----	Socket, 40 Pin DIP	553-66
TP1 thru TP27	Pin, Test Point	706-44

Table 6-23. A13 Switching Power Supply (660-D-8013)

CAPACITORS					
REF. DES.	DESCRIPTION	WILTRON PART NO.			
C1	Monolithic, .1 μF, 50V	230-37	C23	Tantalum, 6.8 μF, 35V	250-41A
C2	Tantalum, 1 μF, 35V	250-19	C24	Disc., .0027 μF, 100V	230-34
C3	Tantalum, 10 μF, 25V	250-42	C25	Disc., .0027 μF, 100V	230-34
C4	Monolithic, .1 μF, 50V	230-37	C26	Tantalum, 6.8 μF, 35V	250-41A
C5	Mylar, 1000 pF, 500V, 5%	227-13	C27	Electrolytic, 150 μF, 25V	250-52
C6	Tantalum, 10 μF, 25V	250-42	C28	Electrolytic, 150 μF, 25V	250-52
C7	Tantalum, 2.2 μF, 20V	250-40	C29	Tantalum, 6.8 μF, 35V	250-41A
C8	Tantalum, 4.7 μF, 35V	250-39	C30	Tantalum, 6.8 μF, 35V	250-41A
C9	Mylar, .01 μF, 200V	210-20	C31	Tantalum, 6.8 μF, 35V	250-41A
C10	Monolithic, .1 μF, 50V	230-37	C32	Tantalum, 6.8 μF, 35V	250-41A
C11	Mylar, 1000 pF, 500V, 5%	227-13	C33	Electrolytic, 47 μF, 63V	250-51
C12	Monolithic, .1 μF, 50V	230-37	C34	Disc., .0027 μF, 100V	230-34
C13	Tantalum, 10 μF, 25V	250-42	C35	Tantalum, 6.8 μF, 35V	250-41A
C14	Tantalum, 12 μF, 350V	250-85	C36	Disc., .002 μF, 500V	230-33
C15	Tantalum, 12 μF, 350V	250-85	C37	Disc., .002 μF, 500V	230-33
C16	Mica, 470 pF	220-470	C38	Tantalum, 6.8 μF, 35V	250-41A
C17	Disc., .0027 μF, 100V	230-34	C39	Mylar, .1 μF, 250V	210-30
C18	Disc., .0027 μF, 100V	230-34	C40	Electrolytic, 47 μF, 63V	250-51
C19	Tantalum, 6.8 μF, 35V	250-41A	C41	Tantalum, 6.8 μF, 35V	250-41A
C20	Electrolytic, 150 μF, 25V	250-52	C42	Disc., .002 μF, 500V	230-33
C21	Electrolytic, 150 μF, 25V	250-52	C43	Disc., .002 μF, 500V	230-33
C22	Tantalum, 6.8 μF, 35V	250-41A	C44	Tantalum, 6.8 μF, 35V	250-41A
			C45	Mylar, .1 μF, 250V	210-30
			C46	Electrolytic, 47 μF, 63V	250-51
			C47	Tantalum, 6.8 μF, 35V	250-41A
			C48	Monolithic, .1 μF, 50V	230-37
			C49	Mica, 15 pF	220-15

C50	Disc, Ceramic, .01 μ F, 1kV	230-40
C51	Disc, Ceramic, .01 μ F, 1kV	230-40
C52	Tantalum, .0047 μ F, 3kV	250-97
C53	Tantalum, .0047 μ F, 3kV	250-97

DIODES

REF. DES.	DESCRIPTION	WILTRON PART NO.
CR1	Silicon, 1N4446	10-1N4446
CR2	Silicon, 1N4446	10-1N4446
CR3	Silicon, 1N4446	10-1N4446
CR4	Silicon, 1N4446	10-1N4446
CR5	Silicon, 1N4446	10-1N4446
CR6	Silicon, 1N4446	10-1N4446
CR7	Silicon, 1N4446	10-1N4446
CR8	Silicon, 1N4446	10-1N4446
CR9	Zener, 15V, 1W, 5%, 1N4744A	10-1N4744A
CR10	Silicon, 1N4446	10-1N4446
CR11	Fast Recovery, 400V, 1A, 1N4936	10-23
CR12	Fast Recovery, 400V, 1A, 1N4936	10-23
CR13	Schottky, 40V, 5A, 1N5825	10-22
CR14	Schottky, 40V, 5A, 1N5825	10-22
CR15	Zener, 25V, 5W, 5%, 1N5360A	10-24
CR16	Fast Recovery, 100V, 3A, MR851	10-27
CR17	Fast Recovery, 100V, 3A, MR851	10-27
CR18	Fast Recovery, 100V, 3A, MR851	10-27
CR19	Fast Recovery, 100V, 3A, MR851	10-27
CR20	Fast Recovery, 200V, 3A, MR852	10-26
CR21	Fast Recovery, 200V, 3A, MR852	10-26
CR22	Fast Recovery, 200V, 3A, MR852	10-26
CR23	Fast Recovery, 200V, 3A, MR852	10-26
CR24	Fast Recovery, 200V, 3A, MR852	10-26
CR25	Fast Recovery, 200V, 3A, MR852	10-26
CR26	Fast Recovery, 400V, 2A, MR854	10-25
CR27	Fast Recovery, 400V, 2A, MR854	10-25
CR28	Fast Recovery, 100V, 1A, 1N4934	10-31
CR29	Fast Recover, 100V, 1A, 1N4934	10-31

INDUCTOR ASSEMBLIES

REF. DES.	DESCRIPTION	WILTRON PART NO.
L1	SPEC-A-8076	310-66
L2	SPEC-A-8077	310-67
L3	SPEC-A-8074	310-64
L4	SPEC-A-8075	310-65
L5	SPEC-A-8076	310-66
L6	SPEC-A-8074	310-64

TRANSISTORS

REF. DES.	DESCRIPTION	WILTRON PART NO.
Q1	PNP, 2N2907	20-2N2907
Q2	NPN, 2N2222A	20-2N2222A
Q3	PNP, MPSA92	20-MPSA92
Q4	PNP, MPSA92	20-MPSA92
Q5	HEXFET, 1 Ω , 350V, 3.5A, 1RF730	20-39
Q6	HEXFET, 1 Ω , 350V, 3.5A, 1RF730	20-39

RESISTORS

REF. DES.	DESCRIPTION	WILTRON PART NO.
R1	MF, 1/4W, 1%, 147 Ω	110-147-1
R2	MF, 1/4W, 1%, 3.16k	110-3.16k-1
R3	MF, 1/4W, 1%, 22.1k	110-22.1k-1
R4	MF, 1/4W, 1%, 2.26k	110-2.26k-1
R5	MF, 1/4W, 1%, 22.1k	110-22.1k-1
R6	Trimmer, 1k	156-1k
R7	MF, 1/4W, 1%, 6.49k	110-6.49k-1
R8	CC, 1/4W, 5%, 22M	101-22M-5
R9	MF, 1/4W, 1%, 42.2k	110-42.2k-1
R10	MF, 1/4W, 1%, 4.53k	110-4.53k-1
R11	MF, 1/4W, 1%, 147 Ω	110-147-1
R12	MF, 1/4W, 1%, 750k	110-750k-1
R13	MF, 1/4W, 1%, 10k	110-10k-1
R14	MF, 1/4W, 1%, 10k	110-10k-1
R15	MF, 1/4W, 1%, 3.32k	110-3.32k-1
R16	MF, 1/4W, 1%, 3.32k	110-3.32k-1
R17	MF, 1/4W, 1%, 499 Ω	110-499-1
R18	MF, 1/4W, 1%, 499 Ω	110-499-1
R19	MF, 1/4W, 1%, 24.9k	110-24.9k-1
R20	MF, 1/4W, 1%, 1.47k	110-1.47k-1
R21	MF, 1/4W, 1%, 10k	110-10k-1
R22	MF, 1/4W, 1%, 100k	110-100k-1
R23	MF, 1/4W, 1%, 14.7k	110-14.7k-1
R24	MF, 1/4W, 1%, 13.3k	110-13.3k-1
R25	MF, 1/4W, 1%, 6.81k	110-6.81k-1
R26	MF, 1/4W, 1%, 8.45k	110-8.45k-1
R27	Trimmer, 5k	156-5k
R28	MF, 1/4W, 1%, 1k	110-1k-1
R29	MF, 1/4W, 1%, 1k	110-1k-1
R30	MF, 1/4W, 1%, 1k	110-1k-1
R31	MF, 1/4W, 1%, 1k	110-1k-1
R32	CC, 1/2W, 5%, 100k	102-100k-5
R33	CC, 1/2W, 5%, 100k	102-100k-5
R34	CC, 1/2W, 5%, 100k	102-100k-5
R35	CC, 2W, 5%, 750 Ω	104-750-5
R36	MF, 1/4W, 1%, 10 Ω	110-10-1
R37	MF, 1/4W, 1%, 10 Ω	110-10-1
R38	MF, 1/4W, 1%, 30.1 Ω	110-30.1-1
R39	MF, 1/4W, 1%, 30.1 Ω	110-30.1-1
R40	CC, 1/2W, 5%, 51 Ω	102-51-5
R41	MF, 1/4W, 1%, 100 Ω	110-100-1
R42	MF, 1/4W, 1%, 100 Ω	110-100-1
R43	CC, 1/2W, 5%, 150 Ω	102-150-5
R44	CC, 1/2W, 5%, 150 Ω	102-150-5
R45	MF, 1/4W, 1%, 100 Ω	110-100-1
R46	MF, 1/4W, 1%, 1k	110-1k-1
R47	CC, 2W, 5%, 750 Ω	104-750-5

<u>TRANSFORMERS</u>		
REF. DES.	DESCRIPTION	WILTRON PART NO.
T1	Driver Transformer Assy SPEC-A-8078	320-56
T2	Driver Transformer Assy SPEC-A-8078	320-56
T3	Output Transformer Assy SPEC-A-8079	320-57
T4	Common-Mode-Isolation	320-70
<u>INTEGRATED CIRCUITS</u>		
REF. DES.	DESCRIPTION	WILTRON PART NO.
U1	Voltage Regulator, 12V, UA7812	54-LM340T-12

U2	Op Amp, LF356H	50-2
U3	Timer, 555NE	54-555
U4	Pulse Width Modulator, MC3420P	54-140

MISCELLANEOUS

REF. DES.	DESCRIPTION	WILTRON PART NO.
TP1 thru TP10	Pins, Test Point	706-44
----	Ejector, P.C. Board	553-96
----	Insulator for Q5 and Q6	790-67

Table 6-24. A14 Motherboard (660-D-8014)

<u>CAPACITORS</u>			<u>DIODES AND BRIDGE RECTIFIER</u>		
REF. DES.	DESCRIPTION	WILTRON PART NO.	REF. DES.	DESCRIPTION	WILTRON PART NO.
C1	Disc Ceramic, 500V, 0.001 μ F	230-3	CR1	Zener, 18V, 0.4W	10-1N967B
C2	Disc Ceramic, 500V, 0.001 μ F	230-3	CR2	Zener, 5.6V, 0.4W	10-1N752A
C3	Disc Ceramic, 500V, 0.001 μ F	230-3	CR3	Silicon, 1N4446	10-1N4446
C4	Electrolytic, 35V, 470 μ F	250-87	CR4	Silicon, 1N4446	10-1N4446
C5	Disc Ceramic, 1kV, 0.01 μ F	230-40	CR5	Silicon Rectifier, SI2	10SI2
C6	Disc Ceramic, 1kV, 0.01 μ F	230-40	CR6	Silicon Rectifier, SI2	10-SI2
C7	Disc Ceramic, 1kV, 0.01 μ F	230-40	CR7	Silicon Rectifier, SI2	10-SI2
C8	Disc Ceramic, 1kV, 0.01 μ F	230-40	CR8	Silicon Rectifier, SI2	10-SI2
C9	Disc Ceramic, 1kV, 0.01 μ F	230-40	CR9	Silicon Rectifier, SI2	10-SI2
C10	Disc Ceramic, 1kV, 0.01 μ F	230-40	CR10	Silicon Rectifier, SI2	10-SI2
C11	Disc Ceramic, 1kV, 0.01 μ F	230-40	CR11	Silicon Rectifier, SI2	10-SI2
C12	Electrolytic, 200V, 850 μ F	250-86	CR12	Bridge Rectifier	60-13
C13	Electrolytic, 200V, 850 μ F	250-86	CR13	Silicon, 1N4446	10-1N4446
C14	Disc Ceramic, .01 μ F	230-11	CR14	Zener, 4.7V, 0.4W	10-11
C15	Tantalum, 35V, 6.8 μ F	250-41A	CR15	Silicon Rectifier, SI2	10-SI2
C16	Tantalum, 35V, 6.8 μ F	250-41A	CR16	Silicon Rectifier, SI2	10-SI2
C17	Tantalum, 35V, 6.8 μ F	250-41A	CR17	Silicon, 1N4446	10-1N4446
C18	Electrolytic, 63V, 10 μ F	250-34	CR18	Silicon, 1N4446	10-1N4446
C19	Tantalum, 35V, 6.8 μ F	250-41A	CR19	Silicon, 1N4446	10-1N4446
C20	Tantalum, 35V, 6.8 μ F	250-41A	CR20	Silicon, 1N4446	10-1N4446
C21	Electrolytic, 63V, 47 μ F	250-51	CR21	Silicon Rectifier, SI2	10-SI2
C22	Electrolytic, 25V, 100 μ F	250-50	CR22	Silicon, 1N4446	10-1N4446
C23	Tantalum, 25V, 10 μ F	250-42	CR23	Silicon Rectifier, SI2	10-SI2
C24	Tantalum, 25V, 10 μ F	250-42	CR24	Silicon Rectifier, SI2	10-SI2
C25	Tantalum, 25V, 10 μ F	250-42	CR25	Silicon Rectifier, SI2	10-SI2
C26	Tantalum, 35V, 1 μ F	250-19	CR26	Silicon Rectifier, SI2	10-SI2
C27	Mylar, 250V, 0.1 μ F	210-30	CR27	Silicon Rectifier, SI2	10-SI2
C28	Mica, 560pF	223-560	CR28	Silicon Rectifier, SI2	10-SI2
C29	Mica, 560pF	223-560	CR29	Silicon Rectifier, SI2	10-SI2
C30	Mica, 560pF	223-560	CR29	Silicon Rectifier, SI2	10-SI2
C31	Mica, 560pF	223-560	CR30	Silicon Rectifier, SI2	10-SI2
C32	Disc Ceramic, .01 μ F	230-11	CR31	Silicon Rectifier, SI2	10-SI2
C33	Monolithic, 100V, 0.1 μ F	230-37	CR32	Silicon Rectifier, SI2	10-SI2
C34	Tantalum, 35V, 6.8 μ F	250-41A	CR33	Silicon Rectifier, SI2	10-SI2
C35	Monolithic, 100V, .1 μ F	230-37	CR34	Silicon, 1N4446	10-1N4446
C36	Electrolytic, 63V, 10 μ F	250-34	CR35	Silicon, 1N4446	10-1N4446
C37	Tantalum, 1 μ F, 35V	250-19	CR36	Silicon, 1N4446	10-1N4446

Table 6-26. Options and Accessories Parts List

<u>Option 1, Rack Mount</u>		<u>Option 3, GPIB Interface</u>	
NAME	PART NO.		
Left Side Assembly	660-D-8111	A1 GPIB Interface PCB (see Table 6-1)	660-D-8001-3
Right Side Assembly	660-D-8112	A18 GPIB Connector PCB (see Table 6-25; attached to rear panel)	660-B-8018
<u>Option 2, Step Attenuator</u>		<u>Option 11, External Square-Wave Input, Standard (except 6642A)</u>	
Step Attenuator	1010-27	PIN Switch Modulator	1020-17
Cable Assembly, Coupler to Step Attenuator	660-A-8121-1	<u>Option 13, Counted Markers</u>	
Cable Assembly, Attenuator to Rear Panel	660-A-8143-1	BNC Connector, Rear-Panel	510-42
Connector Housing, 9-pin	551-200	<u>Accessories</u>	
		PCB Extender Board	660-D-8062-3

Table 7-1. Service Section Organization

TITLE OF INFORMATION	PAGE	PARAGRAPH
Removal and Installation Procedures	7-1	7-3
Overall Circuit Description	7-8	7-4
Overall Troubleshooting, Description Overall Troubleshooting Flowchart	7-17 7-16	7-5
A12 Microprocessor PCB, Description A12 PCB Schematic A12 PCB Troubleshooting Flowchart	7-17 7-22 7-28	7-6
A11 Front Panel PCB, Description A11 PCB Schematic	7-35 7-39	7-7
A1 GPIB Interface PCB, Description A1 PCB Schematic A1 PCB Troubleshooting Flowchart	7-41 7-45 7-48	7-8
A2 Ramp Generator PCB, Description A2 PCB Schematic A2 PCB Troubleshooting Flowchart	7-55 7-60 7-65	7-9
A3 Marker Generator PCB, Description A3 PCB Schematic A3 Troubleshooting Flowchart	7-67 7-73 7-79	7-10
A4 Automatic Level Control PCB, Description A4 PCB Schematic A4 PCB Troubleshooting Flowchart	7-83 7-86 7-93	7-11
A5 Frequency Instruction and A6-A9 YIG Driver PCBs, Description A5 PCB Schematic A6 PCB Description, Assy. 660-D-8007-3, -5, -7, & -99-91 A6 PCB Description, Assy. 660-D-8007-4 A6 PCB Description, Assy. 660-D-8007-6 A6 PCBs Description, Assy. 660-D-8190 and -8191 A7-A9 PCBs Description, Assy. 660-D-8008 and -8009, All Dash Numbers A5-A9 PCB Troubleshooting Flowcharts	7-106 7-106 7-115 7-128 7-134 7-140 7-148 7-171	7-12
A10 FM/Attenuator PCB, Description A10 PCB Schematic A10 PCB Troubleshooting Flowchart	7-175 7-178 7-181	7-13
RF Deck, Description Model 6609A RF Deck Block Diagram Model 6617A RF Deck Block Diagram Model 6621A/6621A-40 RF Deck Block Diagram Model 6629A/6629A-40 RF Deck Block Diagram Model 6627A/6637A-40/6638A RF Deck Block Diagram Model 6642A RF Deck Block Diagram Model 6647A/6648A RF Deck Block Diagram Model 6653A RF Deck Block Diagram Model 6659A RF Deck Block Diagram	7-183 7-184 7-184 7-185 7-185 7-185 7-187 7-186 7-188 7-189	7-14
A13/A14 PCBs Switching Power Supply, Description A13/A14 PCB Schematic A14 Motherboard PCB Wire Lists A13/A14 PCBs Troubleshooting Flowcharts A13 PCB Low-Voltage Troubleshooting Procedure	7-190 7-195 7-202 7-229 7-233	7-15
A18 GPIB Connector PCB, Description A18 PCB Schematic	7-230 7-237	7-16